

FOR OFFICIAL USE

--	--	--	--	--	--

Total for
Sections B & C

--

X275/12/02

NATIONAL WEDNESDAY, 15 MAY
QUALIFICATIONS 1.00 PM – 3.30 PM
2013

**HUMAN BIOLOGY
HIGHER (REVISED)**

Fill in these boxes and read what is printed below.

Full name of centre

--

Town

--

Forename(s)

--

Surname

--

Date of birth

Day Month Year

--	--	--	--	--	--

Scottish candidate number

--	--	--	--	--	--	--	--	--	--

Number of seat

--

SECTION A—Questions 1–30 (30 marks)

Instructions for completion of Section A are given on page two.

For this section of the examination you must use an **HB pencil**.

SECTIONS B AND C (100 marks)

- (a) All questions should be attempted.
(b) It should be noted that in **Section C** questions 1 and 2 each contain a choice.
- The questions may be answered in any order but all answers are to be written in the spaces provided in this answer book, **and must be written clearly and legibly in ink**.
- Additional space for answers will be found at the end of the book. If further space is required, supplementary sheets may be obtained from the Invigilator and should be inserted inside the **front** cover of this book.
- The numbers of questions must be clearly inserted with any answers written in the additional space.
- Rough work, if any should be necessary, should be written in this book and then scored through when the fair copy has been written. If further space is required a supplementary sheet for rough work may be obtained from the Invigilator.
- Before leaving the examination room you must give this book to the Invigilator. If you do not, you may lose all the marks for this paper.



Read carefully

- 1 Check that the answer sheet provided is for **Human Biology Higher (Revised) (Section A)**.
- 2 For this section of the examination you must use an **HB pencil**, and where necessary, an eraser.
- 3 Check that the answer sheet you have been given has **your name, date of birth, SCN** (Scottish Candidate Number) and **Centre Name** printed on it.
Do not change any of these details.
- 4 If any of this information is wrong, tell the Invigilator immediately.
- 5 If this information is correct, **print** your name and seat number in the boxes provided.
- 6 The answer to each question is **either** A, B, C or D. Decide what your answer is, then, using your pencil, put a horizontal line in the space provided (see sample question below).
- 7 There is **only one correct** answer to each question.
- 8 Any rough working should be done on the question paper or the rough working sheet, not on your answer sheet.
- 9 At the end of the examination, put the **answer sheet for Section A inside the front cover of this answer book**.

Sample Question

The digestive enzyme pepsin is most active in the

- A stomach
- B mouth
- C duodenum
- D pancreas.

The correct answer is **A**—stomach. The answer **A** has been clearly marked in **pencil** with a horizontal line (see below).



Changing an answer

If you decide to change your answer, carefully erase your first answer and, using your pencil, fill in the answer you want. The answer below has been changed to **D**.



SECTION A

All questions in this section should be attempted.

Answers should be given on the separate answer sheet provided.

1. Which of the following diagrams correctly shows the structure of DNA?

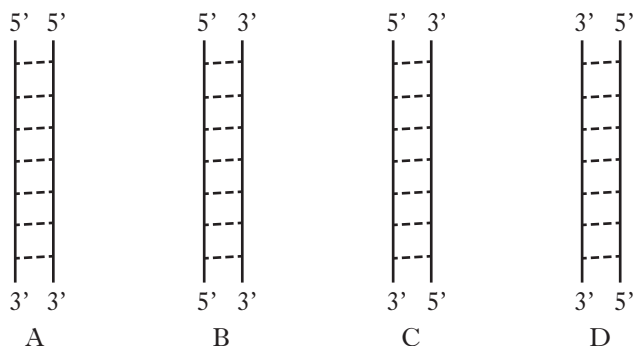

2. If ten percent of the bases in a molecule of DNA are adenine, what is the ratio of adenine to guanine in the same molecule?

- A 1:1
- B 1:2
- C 1:3
- D 1:4

3. The table below contains statements which may be **True** or **False** with regard to DNA replication and mRNA synthesis.

Which line in the table is correct?

	<i>Statement</i>	<i>DNA Replication</i>	<i>mRNA synthesis</i>
A	Occurs in the nucleus	True	False
B	Involved in protein synthesis	True	True
C	Requires free nucleotides	True	False
D	Involves specific base pairing	True	True

4. A variety of proteins can be expressed from the same gene by post-translational modification.

This may involve

- A cutting polypeptide chains and adding carbohydrate to the protein
- B cutting polypeptide chains and removing carbohydrate from the protein
- C cutting mRNA molecules and adding phosphate to the nucleic acid
- D cutting mRNA molecules and removing phosphate from the nucleic acid.

5. Which of the following terms describes types of mutation which occur in both genes and chromosomes?

- A Deletion
- B Insertion
- C Duplication
- D Translocation

6. The following is a list of single gene mutations.

- 1 Nonsense
- 2 Missense
- 3 Frameshift

Which of these gene mutations is the result of a single-nucleotide substitution?

- A 1, 2 and 3
- B 1 and 2 only
- C 3 only
- D 1 only

7. Metabolic pathways can be controlled by feedback inhibition where

- A an end product binds to an enzyme found at the start of the pathway
- B an end product binds to an enzyme found at the end of the pathway
- C an enzyme binds to a substrate found at the start of the pathway
- D an enzyme binds to a substrate found at the end of the pathway.

8. High-energy electrons from NADH are used in the final stage of respiration.

Which of the following statements about the role of these electrons is **not** correct?

- A They are involved in ATP synthesis.
- B They are involved in pumping hydrogen.
- C They are involved in the release of energy.
- D They are involved in the formation of carbon dioxide.

9. A build-up of which of the following combinations of substances would inhibit the activity of phosphofructokinase?

- A Citric acid and ATP
- B ATP and lactic acid
- C Citric acid and creatine phosphate
- D Creatine phosphate and lactic acid

10. The table contains information about the genome of four different species.

Genome size is measured in megabase pairs (Mb). 1 Mb = 1 000 000 base pairs.

<i>Species</i>	<i>Estimated Genome Size (Mb)</i>	<i>Estimated Number of Genes</i>
Chimpanzee	3100	25 000
Human	2900	25 000
Mouse	2750	30 000
Rat	2600	21 000

Which organism has the highest number of genes per megabase pair (Mb)?

- A Chimpanzee
- B Human
- C Mouse
- D Rat

11. The graph below shows changes in the concentration of hormones X and Y in the blood during the menstrual cycle.

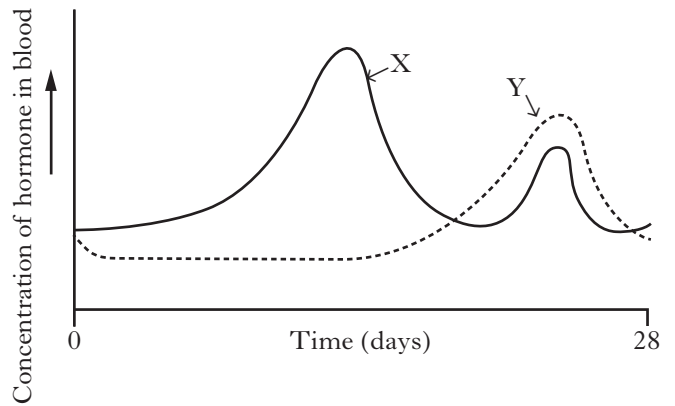

Which of the following correctly identifies hormones X and Y?

	<i>Hormone X</i>	<i>Hormone Y</i>
A	LH	Oestrogen
B	Oestrogen	FSH
C	Oestrogen	Progesterone
D	Progesterone	Oestrogen

12. Changes in the ovary during the menstrual cycle are described below.

- 1 Corpus luteum forms
- 2 Ovulation occurs
- 3 Progesterone is produced
- 4 Corpus luteum degenerates
- 5 Follicle develops

The sequence in which these changes occur following menstruation is

- A 2, 3, 1, 5, 4
- B 2, 1, 3, 4, 5
- C 5, 3, 2, 1, 4
- D 5, 2, 1, 3, 4.

13. Which of the following may need to receive anti-Rhesus antibodies?
- A A Rhesus positive mother after the birth of her Rhesus negative baby
 - B A Rhesus positive mother after the birth of her Rhesus positive baby
 - C A Rhesus negative mother after the birth of her Rhesus negative baby
 - D A Rhesus negative mother after the birth of her Rhesus positive baby.

14. Nicotine is a chemical which may affect ante-natal development.

The diagram shows the stages of development when major and minor malformations of organs may occur if there is exposure to nicotine.

Key – major malformation
 minor malformation

	Stage of development (weeks after fertilisation)														
	Ball of cells		Embryo (organ formation)						Fetus (organ growth and development)						
	1	2	3	4	5	6	7	8	9	10	11	12	13	14	15
brain															
ear															
limbs															
genitalia															

For how many weeks during pregnancy is there a possibility of major malformations to organs during development?

- A 6
 - B 7
 - C 9
 - D 13
15. The morning after pill works by
- A causing thickening of cervical mucus
 - B preventing release of oestrogen
 - C preventing implantation
 - D causing menstruation.

16. The diagram below shows the transmission of the gene for albinism.

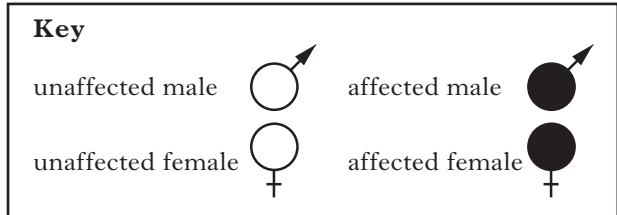
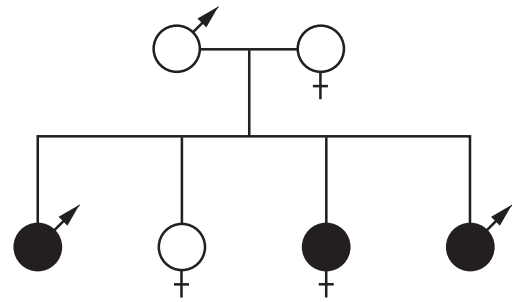

This condition is inherited as a characteristic which is

- A dominant and not sex-linked
- B recessive and not sex-linked
- C dominant and sex-linked
- D recessive and sex-linked.

17. Familial hypercholesterolaemia (FH) is caused by an autosomal dominant allele.

The family history below shows the inheritance of FH through three generations.

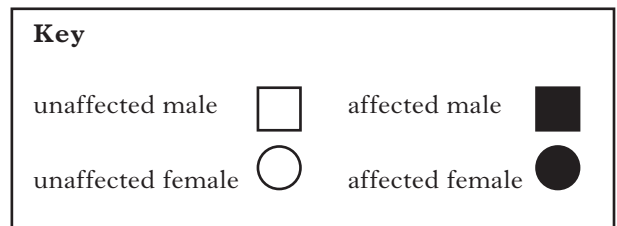
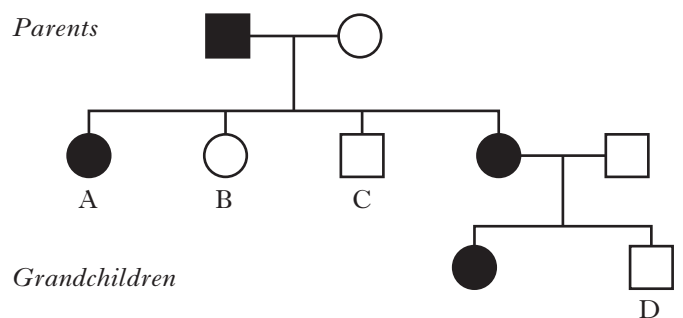

Which individual confirms that this condition is autosomal?

18. The following procedures can be used in the treatment of infertility:

- 1 artificial insemination
- 2 intracytoplasmic sperm injection
- 3 pre-implantation genetic screening.

Which of these procedures involve *in vitro* fertilisation (IVF)?

- A 1 and 2
- B 2 and 3
- C 1 and 3
- D 1, 2 and 3.

19. Which of these cross sections through a blood vessel represents a vein?

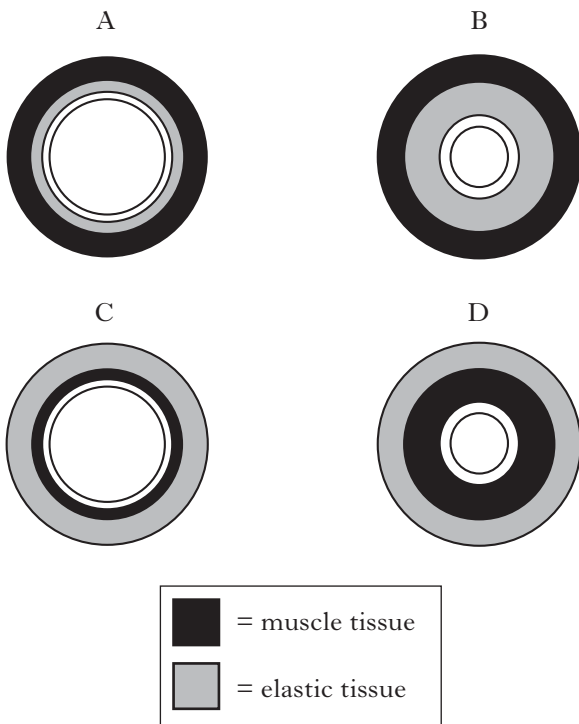

20. Which line in the table below describes correctly the state of the heart valves during ventricular systole?

	<i>Atrio-ventricular</i>	<i>Semi-lunar</i>
A	open	open
B	closed	closed
C	open	closed
D	closed	open

21. During a competition, a trained athlete can increase his cardiac output by 7 times.

If an athlete has a resting heart rate of 60 beats/min and a resting stroke volume of 70 cm³/beat, his maximum cardiac output is

- A 8.2 cm³/min
- B 4200 cm³/min
- C 29 400 cm³/min
- D 36 000 cm³/min.

22. Mean arterial pressure (MAP) is a measure of blood pressure in the arteries.

Pulse pressure is the difference between systolic and diastolic blood pressure.

MAP is calculated using the following formula:

$$\text{MAP} = \text{diastolic pressure} + \left(\frac{\text{pulse pressure}}{3} \right)$$

Using this formula, the MAP of an individual with a blood pressure reading of 122/80 mmHg is

- A 42 mmHg
- B 56 mmHg
- C 94 mmHg
- D 136 mmHg.

23. Statins are drugs which are used to control blood

- A pressure
- B insulin level
- C glucose level
- D cholesterol level.

24. Chronic elevation of blood glucose levels is **not** responsible for which of the following conditions?

- A Renal failure
- B Retinal damage
- C Phenylketonuria
- D Peripheral nerve dysfunction.

25. Which line in the table below identifies correctly the effects of Type 1 and Type 2 diabetes?

	<i>Type 1 diabetes</i>	<i>Type 2 diabetes</i>
A	develops mainly in children	develops mainly in adults
B	cells become insensitive to insulin	cells remain sensitive to insulin
C	no glucose lost in urine	some glucose lost in urine
D	reduced insulin production	no insulin production

26. The graph below shows the effect of the carbon dioxide concentration of inhaled air on the breathing rate of an individual.

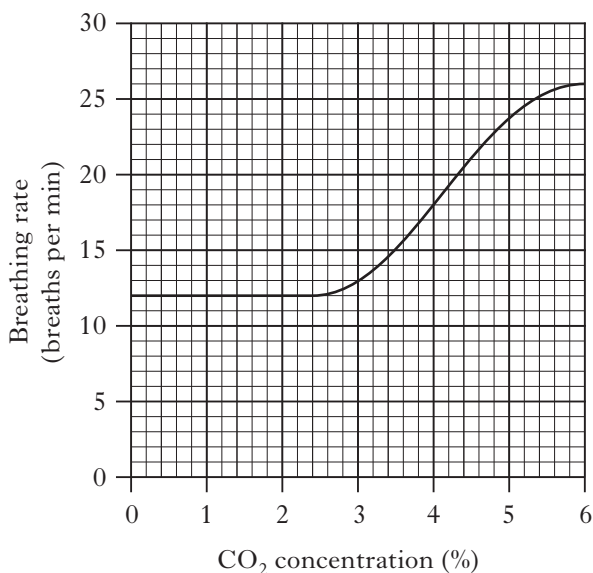

If the volume of one breath is 0.5 litre, what volume of air will be breathed in one minute when the CO₂ concentration is 4%?

- A 6 litres
- B 9 litres
- C 18 litres
- D 36 litres

27. Which of the following statements about Low Density Lipoprotein (LDL) and High Density Lipoprotein (HDL) is correct?

- A LDL deposits cholesterol in the arteries.
- B LDL transports cholesterol to the liver.
- C HDL transports cholesterol to body cells.
- D HDL releases cholesterol in the body cells.

28. The table below contains information about the number of cases of influenza in a city over five years.

<i>Year</i>	<i>Influenza cases in January</i>	<i>Influenza cases in July</i>
2001	580	120
2002	620	345
2003	1200	350
2004	120	145
2005	400	100

Which of the following conclusions can be drawn from the data in the table?

- A There are always more cases of influenza in January than in July.
- B The number of cases of influenza decreased by 75% between January and July of 2005.
- C The greatest percentage decrease in influenza cases occurred between January and July of 2003.
- D The greatest percentage increase in influenza cases occurred between July 2002 and January 2003.

29. Which of the following describes an adjuvant correctly?

- A An inactivated pathogen
- B A weakened pathogen
- C A molecule that inhibits the immune response
- D A molecule that enhances the immune response

30. Which line in the table below classifies correctly the terms which describe the spread of infectious diseases?

	<i>Regular cases in an area</i>	<i>Occasional cases in an area</i>	<i>High number of cases in an area</i>	<i>Cases occur in many countries</i>
A	Endemic	Sporadic	Epidemic	Pandemic
B	Epidemic	Sporadic	Pandemic	Epidemic
C	Endemic	Epidemic	Sporadic	Pandemic
D	Pandemic	Endemic	Epidemic	Sporadic

**Candidates are reminded that the answer sheet MUST be returned
INSIDE the front cover of this answer booklet.**

[Turn over for Section B on *Page ten*

SECTION B

Marks

All questions in this section should be attempted.

All answers must be written clearly and legibly in ink.

1. Trypsin is an enzyme which catalyses the breakdown of proteins in the small intestine.

The graphs below show how pH and temperature affect the activity of trypsin.

Graph 1—effect of pH on trypsin activity

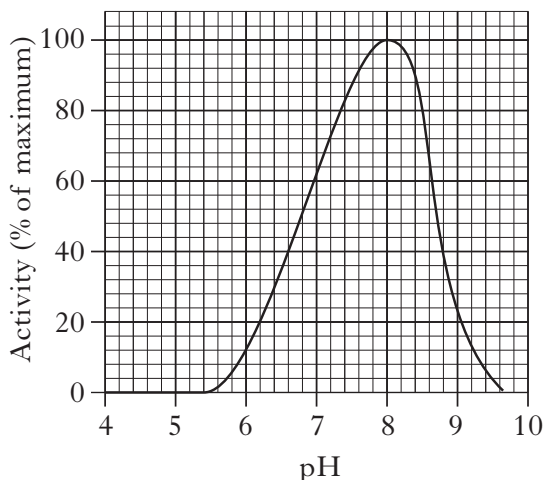

Graph 2—effect of temperature on trypsin activity

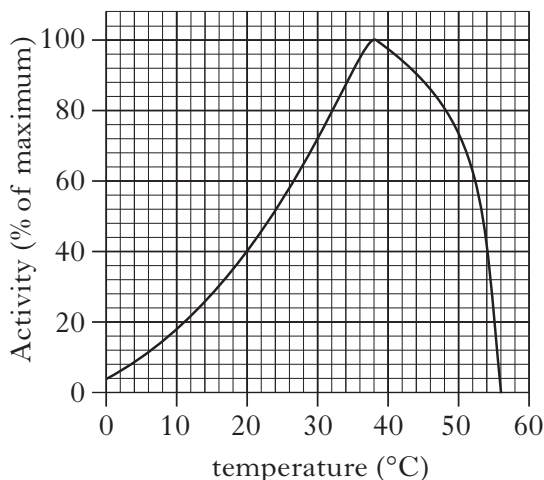

- (a) (i) State the optimum conditions for trypsin activity.

pH _____ temperature _____ °C

1

- (ii) State the range of conditions over which trypsin shows at least 40% of its maximum activity.

1

- (b) Explain the role of the active site in enzyme-catalysed reactions.

3

Marks

2. The diagram below shows the metabolism of three energy sources in a cell.

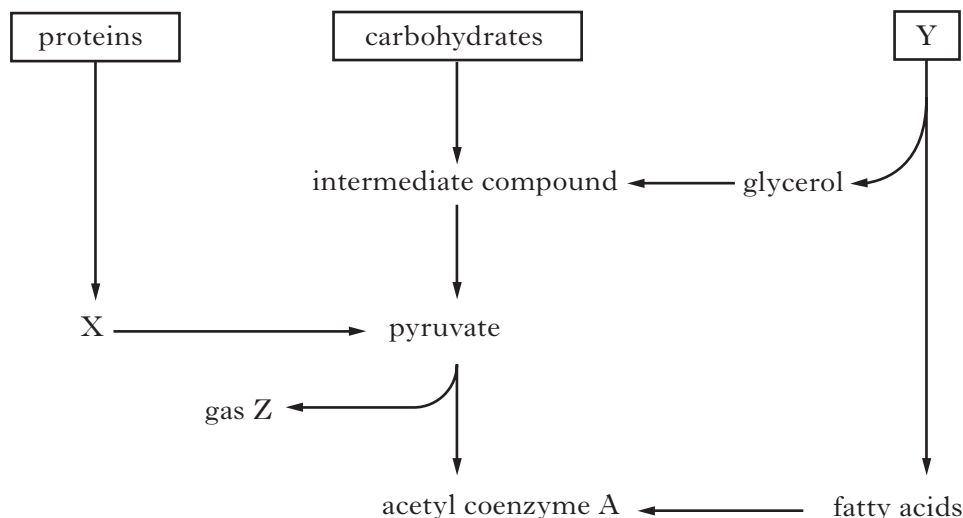

(a) Name X, Y and Z.

X _____

Y _____

Z _____

2

(b) What term describes the breakdown of carbohydrate into pyruvate during respiration?

1

(c) Describe what happens to acetyl coenzyme A during respiration.

1

(d) When might the body obtain most of its energy from proteins?

1

(e) Carbohydrate is stored in the body.

State the form in which carbohydrate is stored and where it is stored.

Storage form _____

Storage location _____

1

[Turn over

Marks

3. The graph below shows how the temperature of the DNA in a reaction tube is changed during one cycle of the polymerase chain reaction (PCR).

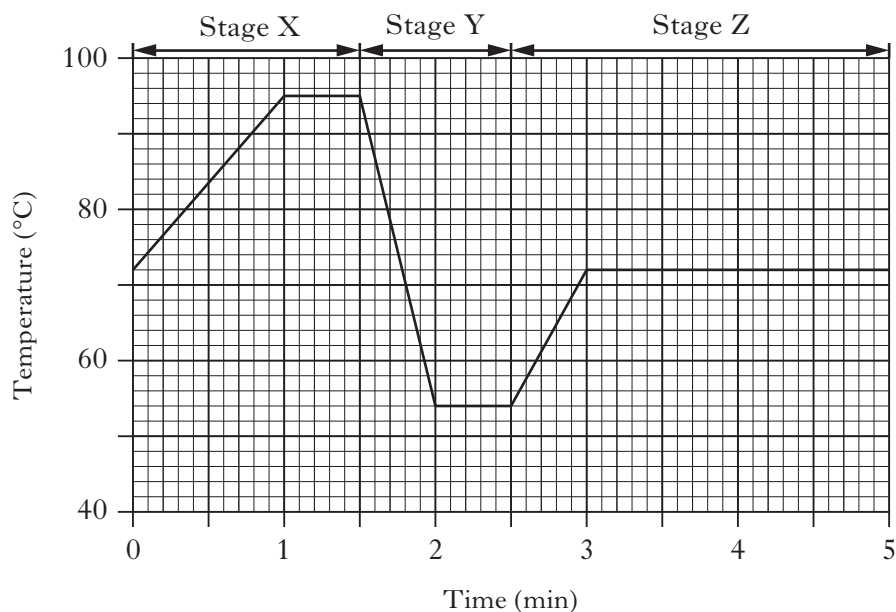

- (a) Calculate the maximum change in temperature that the reaction tube experiences during one cycle of PCR.

Space for calculation

_____ °C **1**

- (b) State the function of PCR.

1

- (c) Describe what happens to the DNA during stage X.

1

Marks

3. (continued)

- (d) Short sections of DNA called primers are involved in Stage Y.
State what happens to these primers during Stage Y.

1

- (e) Suggest why the temperature is increased during Stage Z.

1

- (f) (i) A forensic scientist discovered a tiny spot of blood at a crime scene.
A sample taken from this spot contained 100 molecules of DNA.
The sample underwent PCR cycles for 40 minutes.
Use the graph to calculate how many molecules of DNA would be present after this time.
Space for calculation

_____ molecules

1

- (ii) What process would then allow an individual to be identified from the DNA?

1**[Turn over**

Marks

4. Haemophilia is a sex-linked disorder caused by a recessive allele (h) which results in an individual producing a faulty blood clotting protein.

The diagram below shows the sex chromosomes from two individuals.

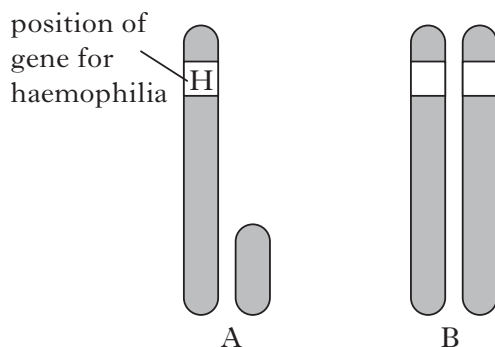

- (a) Individual A is male while individual B is a female carrier of the allele for haemophilia.

- (i) **Complete the diagram** by labelling the alleles on the sex chromosomes of individual B.

1

- (ii) State the genotypes of individuals A and B.

A _____ B _____

1

- (iii) What is the chance that a daughter produced by this couple will have haemophilia?

Explain your answer.

Space for calculation

Chance _____%

Explanation _____

1

- (b) Damage to blood vessels sets in motion a series of events which results in the formation of a blood clot.

A plasma protein is converted into a meshwork of threads, causing the blood to clot.

Name this plasma protein and describe how it is converted into threads.

Protein _____

Description _____

2

Marks

5. The flowchart summarises the processes involved in the production of semen.

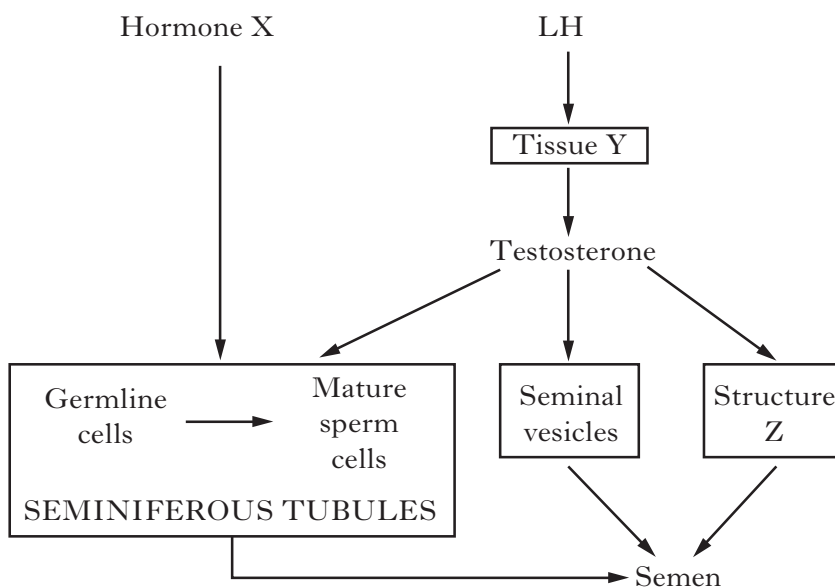

(a) Name hormone X and tissue Y.

Hormone X _____

Tissue Y _____

2

(b) Semen contains substances secreted by structure Z.

(i) Identify structure Z.

1

(ii) Describe the role of the secretions from the seminal vesicles and structure Z.

1

(c) Complete the table to show the percentage of each type of cell which would contain a Y chromosome.

<i>Cells</i>	<i>Percentage of cells containing a Y chromosome</i>
Germline cells	
Mature sperm cells	

1

[Turn over

6. The graphs below show changes in the volume and composition of milk produced by a woman in the first week following the birth of her child.

Graph 1— changes in the volume of milk produced

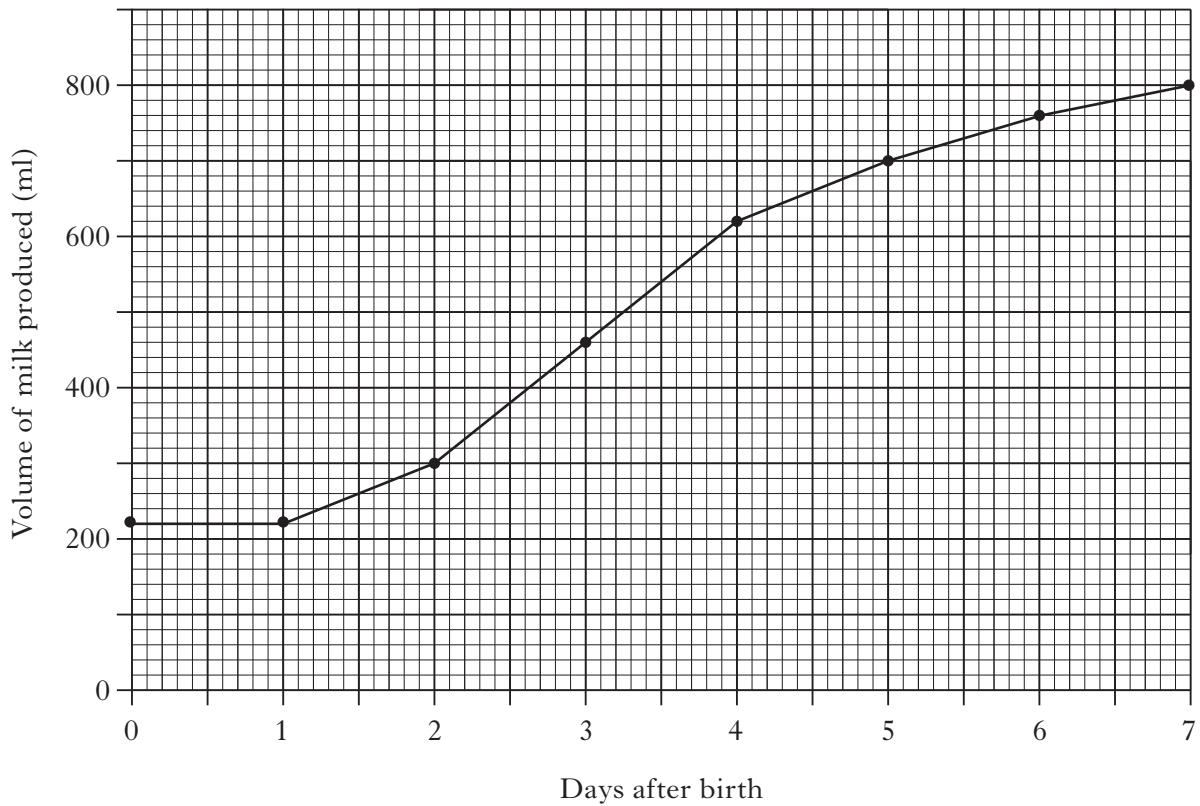

Graph 2— changes in the concentration of lactose sugar and IgA antibody in milk

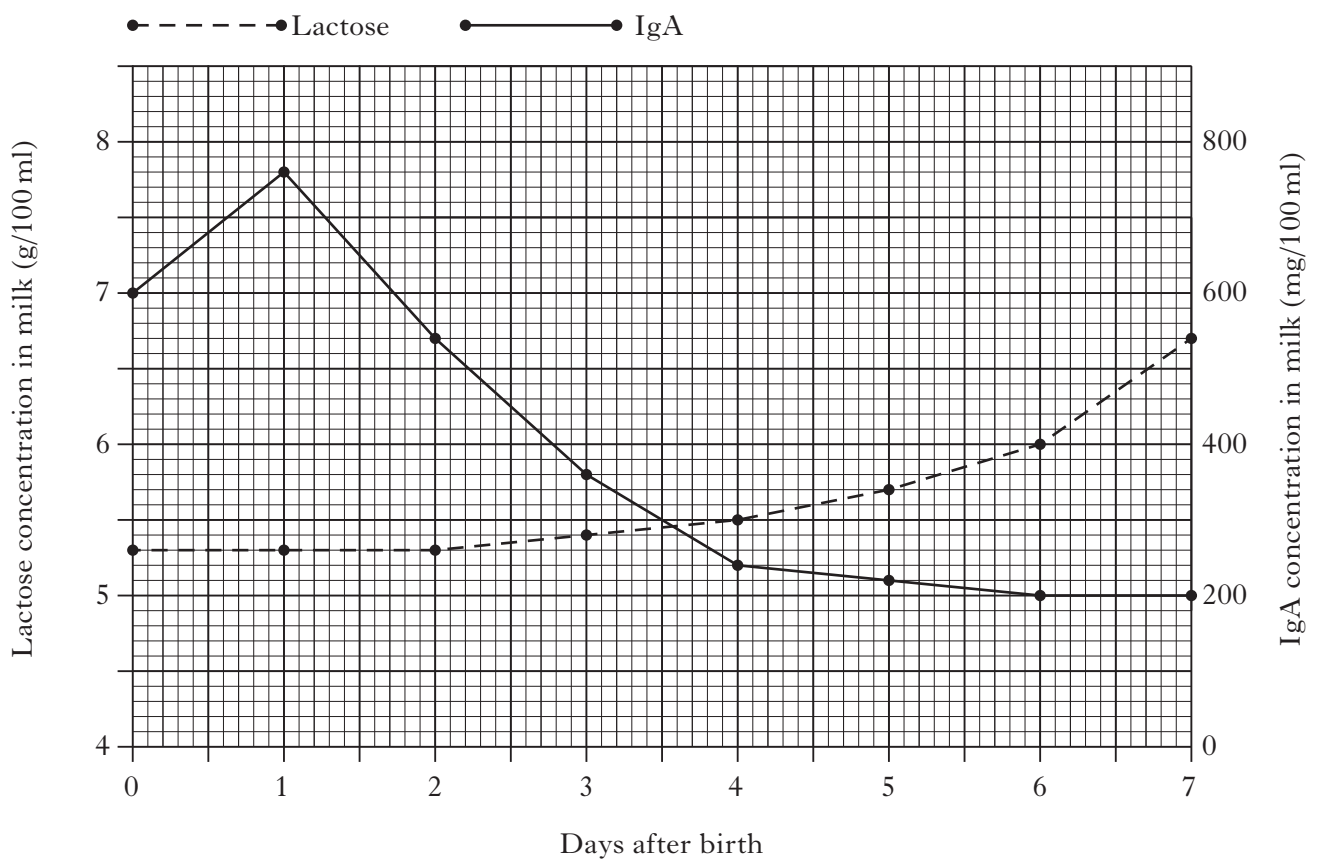

Marks

6. (continued)

- (a) From **Graph 2**, describe **two** ways in which the composition of milk produced in the first three days after birth differs from milk produced later.

1 _____

2 _____

1

- (b) What was the volume of milk produced on day 3?

1

- (c) (i) Between days 2 and 3 this woman produced a constant mass of IgA. Explain why the concentration of IgA in her milk decreased during this time.

1

- (ii) Express, as a simple whole number ratio, the concentration of IgA compared to the concentration of lactose produced on day 6.

(1g = 1000 mg)

Space for calculation

_____ : _____
IgA Lactose

1

- (d) Using **Graphs 1** and **2**, calculate the mass of lactose produced on day 5.

Space for calculation

_____ g

1

[Turn over

Marks

7. The diagram below shows some blood vessels within muscle tissue of an athlete. The direction of blood flow is indicated by the arrows.

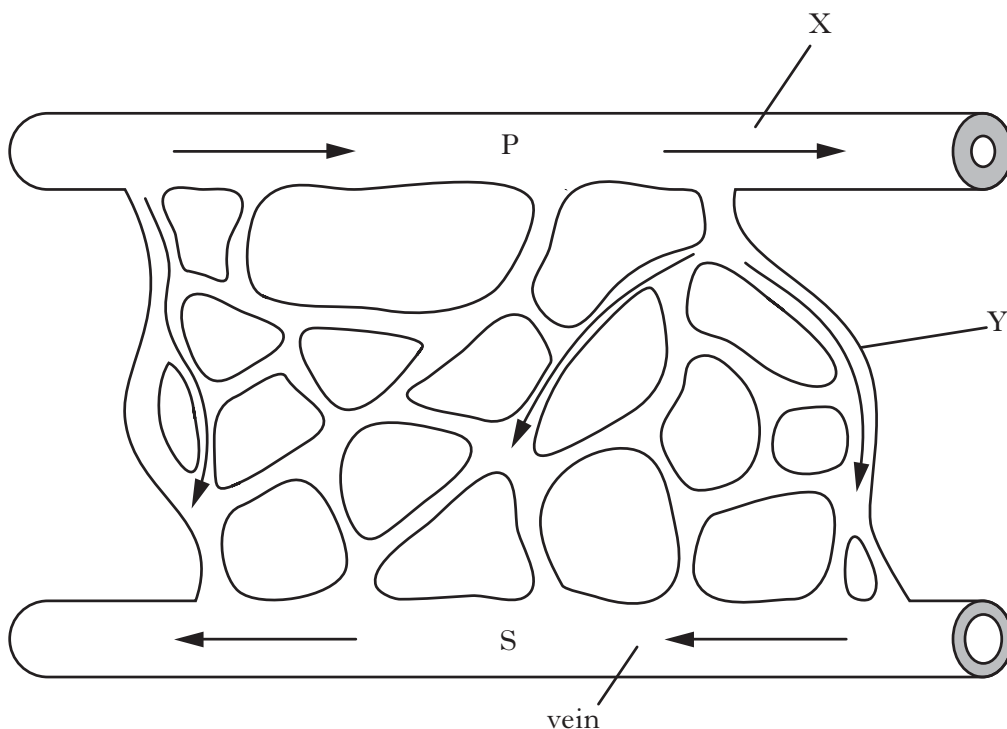

- (a) Name the type of blood vessels labelled X and Y.

X _____

Y _____

1

- (b) Name **two** substances which are at a higher concentration in the blood at point P than at point S.

1 _____

2 _____

1

- (c) The athlete ran on a treadmill at high speed for ten minutes.

Explain why the concentration of lactic acid in his blood increased during this time.

1

- (d) Tissue fluid surrounds the muscle cells.

Some of this fluid is reabsorbed into the bloodstream.

How else is tissue fluid removed from around the muscle cells?

1

Marks

8. The graph below shows changes in the volume of blood in the left ventricle of a man's heart.

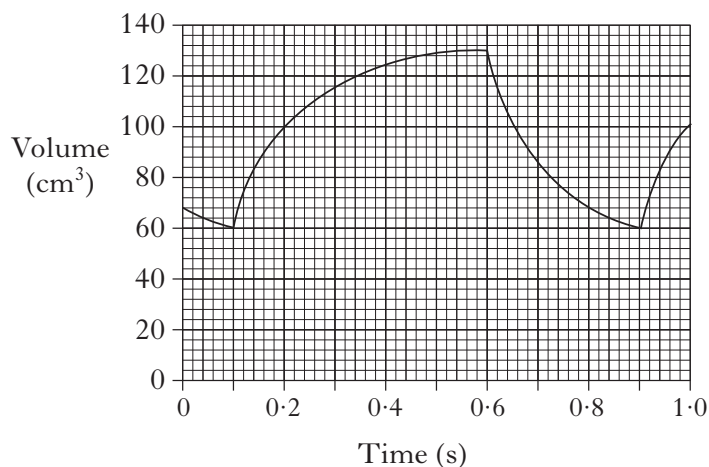

- (a) How long does ventricular systole last?

_____ s **1**

- (b) (i) What is the heart rate of this man?

_____ beats per minute **1**

- (ii) Calculate the volume of blood leaving this man's left ventricle every minute.

Space for calculation

_____ cm³ **1**

- (c) When this man exercises, the volume of blood leaving his heart increases significantly.

Describe how the nervous system and hormones cause this increase.

3

Marks

9. Rising levels of obesity are a major concern in modern Scottish society. Successive governments have tried to promote healthy eating and exercise in an attempt to address this problem.

(a) (i) One measure of obesity is the body mass index (BMI).

What measurements are taken to calculate BMI?

1

(ii) What is the minimum value of BMI that is generally used to indicate that an individual is obese?

1

(b) Why should the dietary intake of carbohydrate in the form of free sugar be limited?

1

(c) Describe how exercise reduces the risk of an individual becoming obese.

1

(d) State **two** ways that exercise reduces the risk factors for cardiovascular disease (CVD).

1 _____

2 _____

1

Marks

10. The diagram below shows a neurone from an adult.

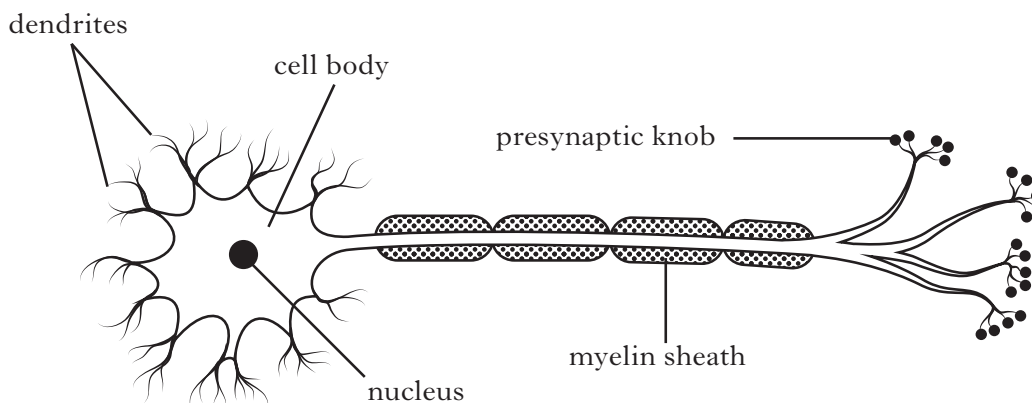

- (a) Draw an arrow **on the diagram** to show the direction in which an impulse would travel. 1
- (b) Suggest a possible role of the nucleus in the transfer of information across a synapse.

1

- (c) Complete the table below which contains information about structures found in the presynaptic knob.

<i>Structure</i>	<i>Function</i>
	Provides ATP for synthesis reactions
Vesicle	

1

- (d) (i) How might a neurone in a newly-born child differ from the one in the diagram?

1

- (ii) In what way would this affect how the neurone functions?

1

[Turn over

Marks

11. Split brain patients cannot transfer information between their left and right cerebral hemispheres because the band of nerve fibres connecting these areas of the brain has been cut.

(a) Name the band of fibres which connects the two hemispheres.

1

(b) Some of the functions of each hemisphere are described in the table below.

These functions are unaffected in split brain patients.

<i>Left cerebral hemisphere</i>	<i>Right cerebral hemisphere</i>
processes information from right eye	processes information from left eye
controls language production	controls movements of left hand

The diagram below shows an experiment on a split brain patient.

The patient was asked to stare at a spot in the centre of a screen and the words “key” and “spoon” were flashed briefly onto the screen in the positions shown.

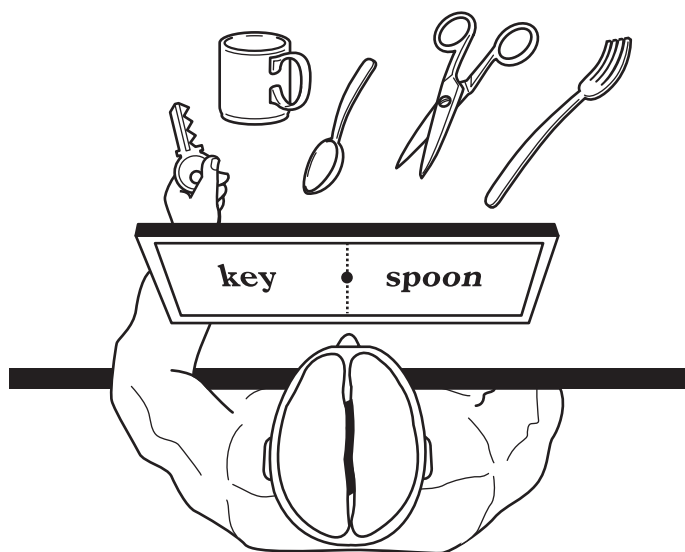

(i) The patient was then told to use his left hand to pick up the objects he saw named on the screen.

Explain why the patient picked up the key but not the spoon.

2

Marks

11. (b) (continued)

- (ii) The patient was then asked to say what he saw written on the screen.
Predict what he would have said and give a reason for your answer.

Prediction _____

1

Reason _____

1

[Turn over

12. An investigation was carried out to determine the effects of a distraction task on the ability to recall words in a list.

Marks

A group of 20 students listened to a list of words being read aloud.

Immediately after the last word had been read out, the students were distracted by being asked to recite the alphabet backwards from Z to A.

They were then asked to write down all the words from the list that they could remember.

The results of this investigation are shown in the table below.

<i>Position of word in list</i>	<i>Number of students remembering word</i>	<i>Position of word in list</i>	<i>Number of students remembering word</i>
1	20	11	2
2	19	12	3
3	18	13	4
4	17	14	2
5	15	15	3
6	10	16	4
7	8	17	3
8	6	18	3
9	4	19	2
10	3	20	3

- (a) Plot a line graph to show the results of the investigation.

(Additional graph paper, if required, can be found on *Page thirty-two*)

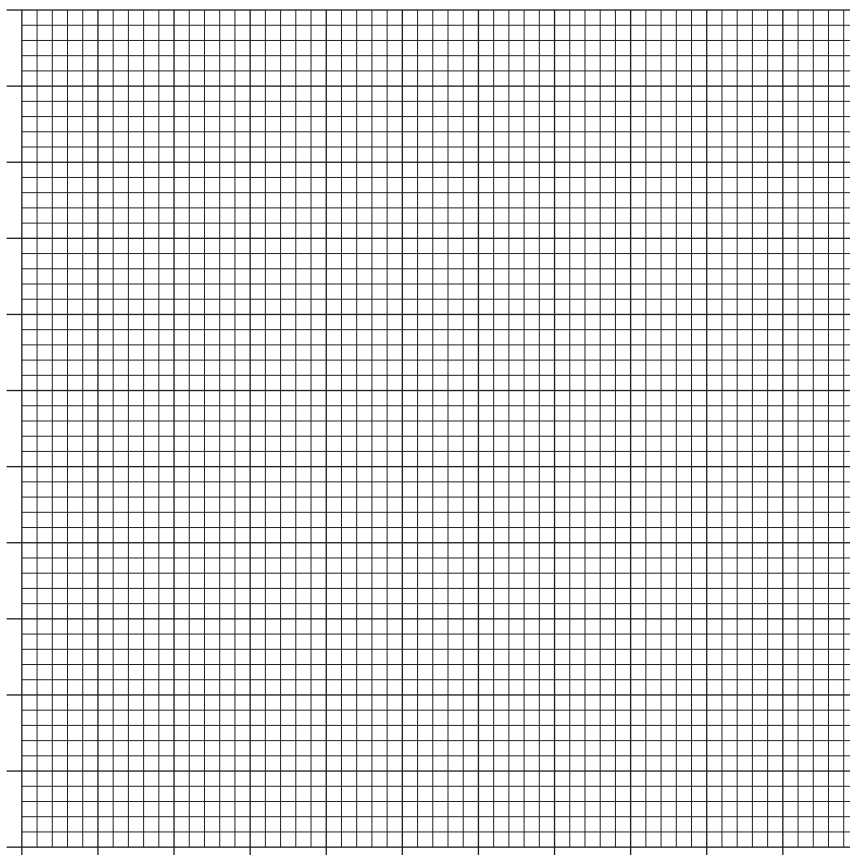

12. (continued)

Marks

- (b) Calculate the percentage decrease in recall between the first and last words read out.

Space for calculation

_____ %

1

- (c) In order to improve the reliability of the results the procedure was repeated with another group of students.

State **three** variables that would have to be kept the same.

1 _____

2 _____

3 _____

2

- (d) A control group of students should have been used in this investigation.

- (i) Describe how the procedure used with the control group should differ from the procedure outlined.

1

- (ii) Suggest how the expected pattern of results from the control group would differ from the results shown in the table.

1

- (e) Explain the effect of the distraction task on memory in this investigation.

1

[Turn over

Marks

13. The following question relates to aspects of learning associated with guitar playing.



(a) What effect does practising a motor skill, such as repeatedly playing chords, have on the nervous system?

1

(b) Suggest how “shaping” might be used by a teacher to help students improve their guitar playing over the course of a year.

2

(c) (i) A teenager decides that she dislikes all of a band’s music after hearing just one song.

What form of learning is this?

1

(ii) As she grows older this teenager’s opinion about the band’s music could be altered by internalisation.

Explain how this may happen.

1

Marks

13. (continued)

(d) Anti-social behaviour can occur when people are together in a group such as at a music festival.

What is the name of this effect and why does it occur?

Name _____

1

Cause _____

1

[Turn over

14. The diagram below shows the structure of one strain of the influenza virus.

Marks

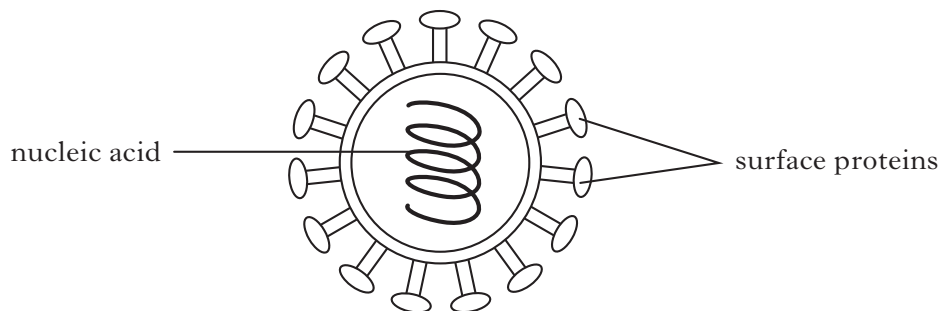

(a) This virus can be used to prepare a flu vaccine. In order to do this the nucleic acid must be broken up but the surface proteins left intact.

Explain why it is necessary to:

(i) break up the nucleic acid _____

(ii) leave the surface proteins intact _____

2

(b) A different vaccine is required against each strain of the influenza virus.

Suggest why different vaccines are required.

1

(c) Researchers are attempting to develop a new vaccine which will be effective against **all** strains of the influenza virus. Trials of this new vaccine have shown that it increases the activity of T-lymphocytes in the body.

Describe **two** ways in which T-lymphocytes combat infection.

1 _____

2 _____

2

(d) Clinical trials of vaccines use randomised, placebo-controlled protocols.

Describe how these protocols are set up by the researchers.

2

SECTION C

Marks

Both questions in this section should be attempted.

Note that each question contains a choice.

Questions 1 and 2 should be attempted on the blank pages which follow.

Supplementary sheets, if required, may be obtained from the Invigilator.

Labelled diagrams may be used where appropriate.

1. Answer **either A or B**.

A Give an account of cell differentiation under the following headings.

- | | |
|-----------------------|-------------|
| (i) Stem cells; | 4 |
| (ii) Somatic cells; | 4 |
| (iii) Germline cells. | 2 |
| | (10) |

OR

B Give an account of skeletal muscle cells under the following headings.

- | | |
|----------------------------------|-------------|
| (i) Lactic acid metabolism; | 4 |
| (ii) Slow twitch muscle fibres; | 3 |
| (iii) Fast twitch muscle fibres. | 3 |
| | (10) |

In question 2, ONE mark is available for coherence and ONE mark is available for relevance.

2. Answer **either A or B**.

A Describe how recreational drugs can affect the brain. **(10)**

OR

B Describe non-specific defences that the body uses to protect itself from pathogens. **(10)**

[END OF QUESTION PAPER]

SPACE FOR ANSWERS

--	--

SPACE FOR ANSWERS

--	--

SPACE FOR ANSWERS

ADDITIONAL GRAPH FOR QUESTION 12(a)

