

FOR OFFICIAL USE

--	--	--	--	--	--

Total for
Sections
B and C

X007/12/02

NATIONAL
QUALIFICATIONS
2015

WEDNESDAY, 13 MAY
1.00 PM – 3.30 PM

BIOLOGY
HIGHER

Fill in these boxes and read what is printed below.

Full name of centre

Town

Forename(s)

Surname

Date of birth

Day Month Year

--	--	--	--	--	--

Scottish candidate number

--	--	--	--	--	--	--	--	--	--

Number of seat

SECTION A—Questions 1–30 (30 Marks)

Instructions for completion of Section A are given on *Page two*.

For this section of the examination you must use an **HB pencil**.

SECTIONS B AND C (100 Marks)

- (a) All questions should be attempted.
(b) It should be noted that in **Section C** questions 1 and 2 each contain a choice.
- The questions may be answered in any order but all answers are to be written in the spaces provided in this answer book, **and must be written clearly and legibly in ink**.
- Additional space for answers will be found at the end of the book. If further space is required, supplementary sheets may be obtained from the Invigilator and should be inserted inside the **front** cover of this book.
- The numbers of questions must be clearly inserted with any answers written in the additional space.
- Rough work, if any should be necessary, should be written in this book and then scored through when the fair copy has been written. If further space is required, a supplementary sheet for rough work may be obtained from the Invigilator.
- Before leaving the examination room you must give this book to the Invigilator. If you do not, you may lose all the marks for this paper.



Read carefully

- 1 Check that the answer sheet provided is for **Biology Higher (Section A)**.
- 2 For this section of the examination you must use an **HB pencil**, and where necessary, an eraser.
- 3 Check that the answer sheet you have been given has **your name, date of birth, SCN** (Scottish Candidate Number) and **Centre Name** printed on it.
Do not change any of these details.
- 4 If any of this information is wrong, tell the Invigilator immediately.
- 5 If this information is correct, **print** your name and seat number in the boxes provided.
- 6 The answer to each question is **either** A, B, C or D. Decide what your answer is, then, using your pencil, put a horizontal line in the space provided (see sample question below).
- 7 There is **only one correct** answer to each question.
- 8 Any rough working should be done on the question paper or the rough working sheet, not on your answer sheet.
- 9 At the end of the examination, put the **answer sheet for Section A inside the front cover of this answer book**.

Sample Question

The apparatus used to determine the energy stored in a foodstuff is a

- A calorimeter
- B respirometer
- C klinostat
- D gas burette.

The correct answer is **A**—calorimeter. The answer **A** has been clearly marked in **pencil** with a horizontal line (see below).



Changing an answer

If you decide to change your answer, carefully erase your first answer and using your pencil fill in the answer you want. The answer below has been changed to **D**.



SECTION A

All questions in this section should be attempted.

Answers should be given on the separate answer sheet provided.

1. The diagram below shows a chloroplast.

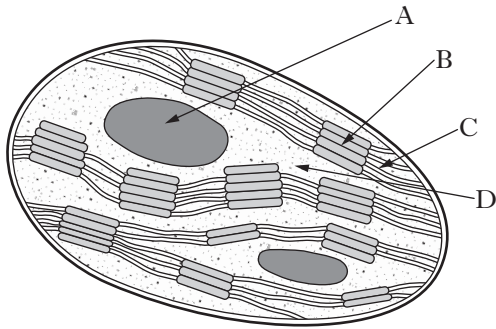

In which region does carbon fixation (Calvin Cycle) occur?

2. The graph below shows the effect of increasing light intensity on the rate of photosynthesis in a green plant.

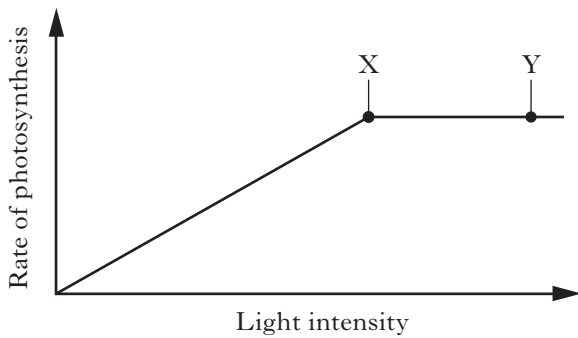

Two environmental factors which could be limiting the rate of photosynthesis between points X and Y are

- A light intensity and oxygen concentration
- B temperature and oxygen concentration
- C temperature and carbon dioxide concentration
- D carbon dioxide concentration and light intensity.

3. The diagram below shows an outline of the carbon fixation stage of photosynthesis.

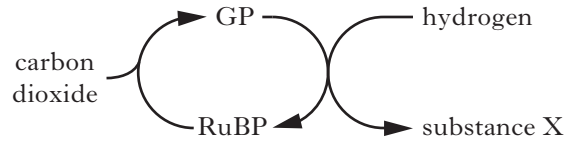

Substance X is

- A ATP
- B glucose
- C oxygen
- D water.

4. The graph below shows the concentrations of glycerate phosphate (GP) and ribulose biphosphate (RuBP) in algal cells kept in an illuminated flask.

The concentration of carbon dioxide in the flask was 0.05% for the first 3 minutes, then it was reduced to 0.005%.

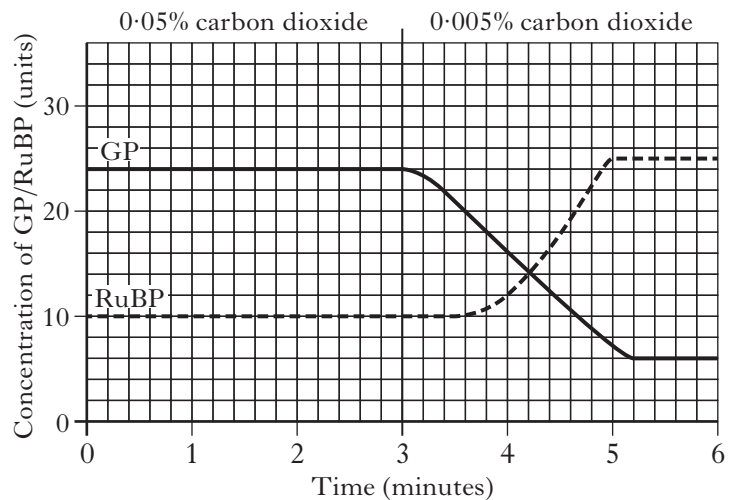

Which of the following statements is correct?

- A The RuBP concentration increases by 150% from 0 to 5 minutes.
- B At 3.6 minutes the concentration of GP is 150% greater than the concentration of RuBP.
- C At 1 minute the concentration of GP is 150% of the concentration of RuBP.
- D The GP concentration decreases by 25% from 0 to 6 minutes.

5. The diagram below shows a plant cell which has been left for a long period in a concentrated sucrose solution.

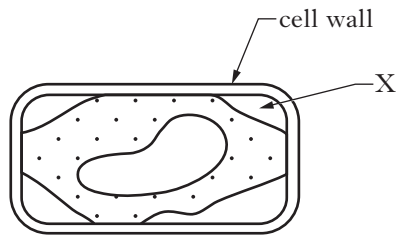

Which line in the table below describes correctly the condition of the cell and the contents of the area labelled X?

	<i>Condition</i>	<i>Area X</i>
A	turgid	water
B	turgid	sucrose solution
C	plasmolysed	water
D	plasmolysed	sucrose solution

6. In cells, anaerobic respiration occurs in the
- A cell cytoplasm
 - B cytochrome system
 - C matrix of mitochondria
 - D cristae of mitochondria.
7. In the anaerobic breakdown of glucose by yeast, which of the following would **not** be formed?
- A Water
 - B ATP
 - C Carbon dioxide
 - D Ethanol

8. If ten percent of the bases in a molecule of DNA are adenine, what is the ratio of adenine to guanine in the same molecule?

- A 1:1
- B 1:2
- C 1:3
- D 1:4

9. The diagram below shows part of a DNA molecule during replication.

Which numbers represent the base cytosine?

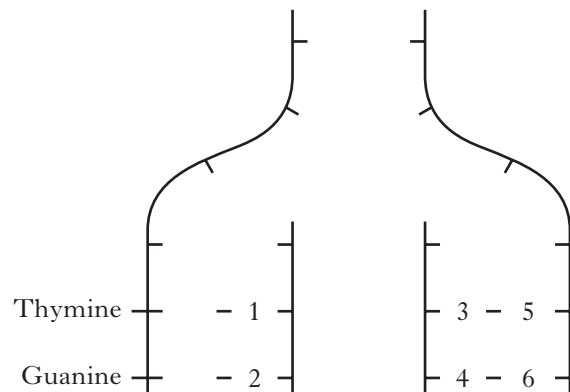

- A 1 and 3
- B 1 and 5
- C 2 and 4
- D 2 and 6

10. The effect of leaf age on the rate of production of cyanide gas by clover leaves was investigated.

Leaf extracts were made by grinding leaves in distilled water. Extracts were placed in containers as shown in the diagram below.

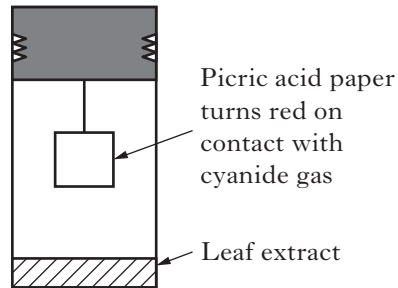

Which line in the table below identifies correctly the factors which should be kept constant during this investigation?

	Factor		
	1	2	3
A	temperature	area of paper	volume of extract
B	age of leaves	volume of extract	area of paper
C	area of paper	time for paper to turn red	temperature
D	volume of extract	temperature	age of leaves

11. In tomato plants, the genes for stem colour and presence of epidermal hairs are found on different chromosomes. The allele for purple stem **P** is dominant to the allele for green stem **p** and the allele for hairy stem **H** is dominant to the allele for smooth stem **h**. The following cross was carried out.



32 offspring were produced from this cross.

How many of these offspring would be expected to have purple, smooth stems?

- A 24
- B 16
- C 8
- D 4

12. The diagram below represents homologous chromosomes pairing during meiosis.

The locations of the alleles of four genes are shown.

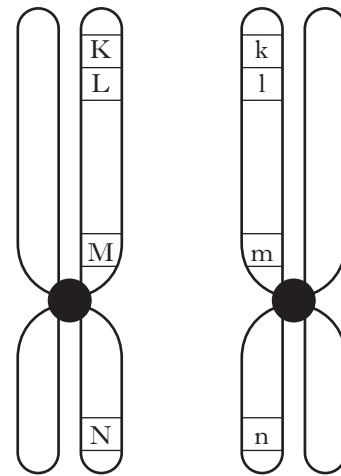

Crossing over between these chromosomes may take place resulting in new combinations of alleles.

Which new combination of alleles is **least** likely to occur?

- A Klmn
- B kLMN
- C klmN
- D KLMn

13. In humans, the ability to taste a certain chemical is controlled by one pair of alleles. The allele which gives the ability to taste the chemical is dominant.

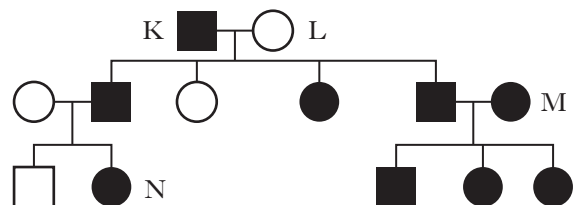

Which of the following conclusions about the individuals indicated in the above family tree may be **incorrect**?

- A K is heterozygous for this characteristic.
- B L is homozygous for this characteristic.
- C M is homozygous for this characteristic.
- D N is heterozygous for this characteristic.

14. Human males affected by Klinefelter syndrome may have two X chromosomes and a Y chromosome (XXY).

This condition arises as a result of

- A recombination
- B sex-linkage
- C crossing-over
- D non-disjunction.

15. A population of 10 million bacteria was exposed to UV light. Two bacteria mutated and developed a resistance to an antibiotic.

What is the frequency of this mutation per million cells?

- A 0.02
- B 0.2
- C 2
- D 20

16. A small sub-population of a species of snail was isolated from the main population by the changing course of a river. The two populations remained isolated for many generations.

Based on this information, which of the following is a **true** statement?

- A The populations of the snail were isolated by a reproductive barrier.
- B Mutations will not occur in the isolated sub-population of snails.
- C Gene flow between the two sub-populations of snail will occur.
- D The effects of natural selection will be different in each population of snail.

17. Selective breeding programmes have produced two varieties of maize, one having grains with a high oil content (Variety P) and another having grains with a low oil content (Variety Q).

The graph below shows the changes in oil content in the two varieties over 100 years of selective breeding.

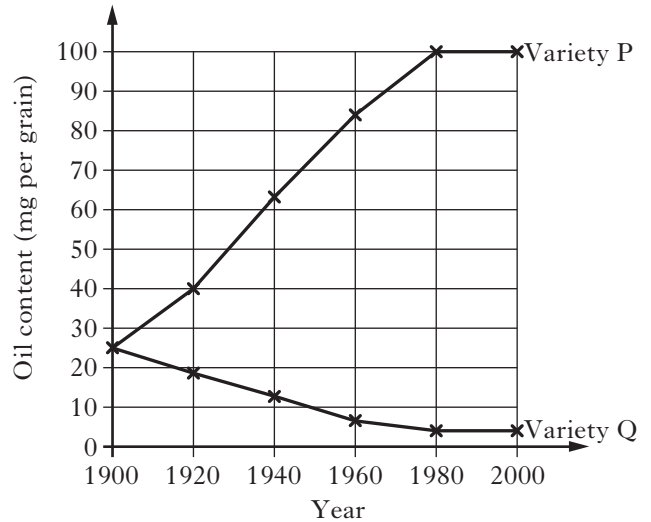

What is the percentage increase in the oil content of variety P over the 100 year period?

- A 75%
- B 95%
- C 300%
- D 1900%

18. The diagram below shows information about the distribution of stomata on the surface of a leaf.

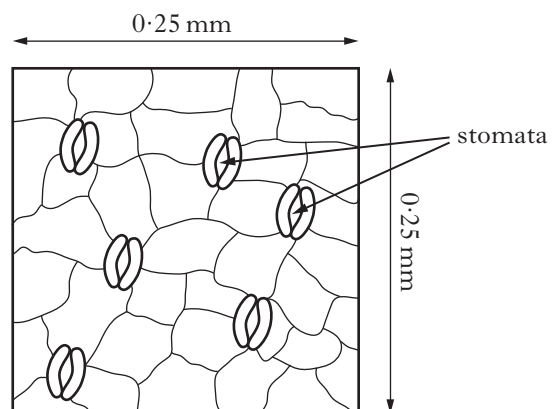

Calculate the expected number of stomata present in an area of 1 mm^2 .

- A 12
- B 24
- C 96
- D 960

19. The list below shows plant adaptations.

- 1 Rolling of leaves
- 2 Large leaf surface area
- 3 Sunken stomata
- 4 Thick cuticle

Which are adaptations of xerophytes?

- A 1, 2 and 4
- B 1, 3 and 4
- C 2, 3 and 4
- D 1, 2 and 3

20. The total water gain by a kangaroo rat over a period of four weeks was investigated.

During this period the rat consumed 100 grams of barley seeds but did not drink any water. The total gain of water over the period was 60 grams.

The table below shows the percentage of the rat's total water gain by metabolism and absorption over the four week period.

<i>Process</i>	<i>% of total water gain from each process over the four week period</i>
metabolism	90
absorption	10

What was the average mass of water gained by the rat from its metabolism over **one** week of the investigation?

- A 13.5 g
- B 22.5 g
- C 54.0 g
- D 90.0 g

21. The diagram below shows some structures within a barley grain.

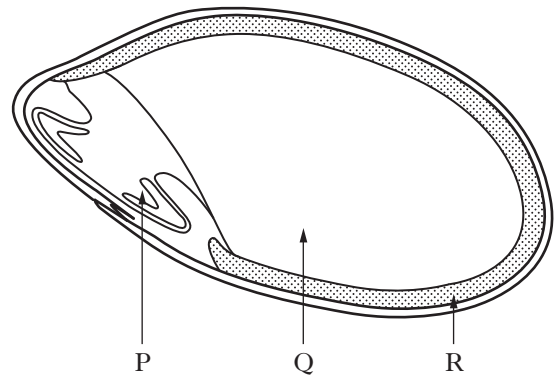

Which line in the table below identifies correctly the site of synthesis and the site of action of the hormone gibberellic acid (GA)?

	<i>Site of synthesis of gibberellic acid (GA)</i>	<i>Site of action of gibberellic acid (GA)</i>
A	P	Q
B	P	R
C	R	Q
D	R	P

[Turn over

22. The flow diagram below outlines processes which occur in the human body to speed up the metabolic rate.

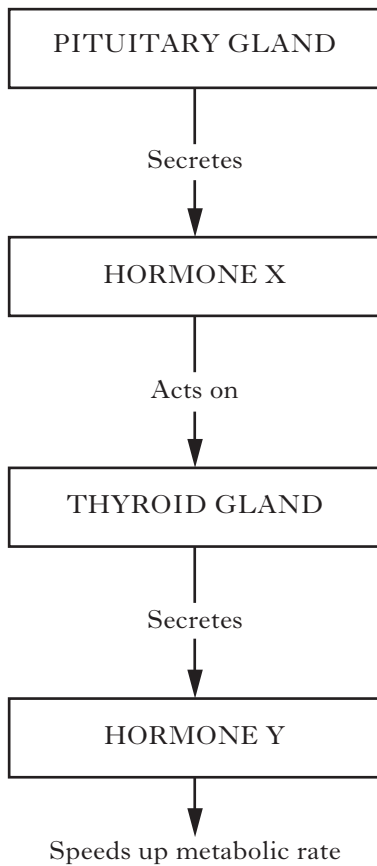

Hormones X and Y are

	X	Y
A	Thyroid Stimulating Hormone (TSH)	Thyroxine
B	Growth Hormone (GH)	Thyroid Stimulating Hormone (TSH)
C	Growth Hormone (GH)	Thyroxine
D	Thyroid Stimulating Hormone (TSH)	Growth Hormone (GH)

23. A plant becomes etiolated when it
- A is grown in soil with low nitrogen levels
 - B is grown in the dark
 - C is treated with gibberellic acid (GA)
 - D has its apical bud removed.

24. Mating frequency was observed in sheep exposed to different periods of light and darkness.

The results are shown in the table below.

Light period (hours)	Dark period (hours)	Mating frequency (0 = no mating) + = occasional ++ = frequent)
6	18	++
8	16	++
10	14	++
12	12	+
13	11	0

From information in the table, what is the critical factor required for mating to take place?

- A A minimum light period of 6 hours.
- B A maximum light period of 10 hours.
- C A minimum dark period of 12 hours.
- D A maximum dark period of 12 hours.

25. The volume of blood in an adult male was found to be 5 litres.

The graph below shows the relationship between the concentrations of glucose and insulin in the bloodstream of this individual.

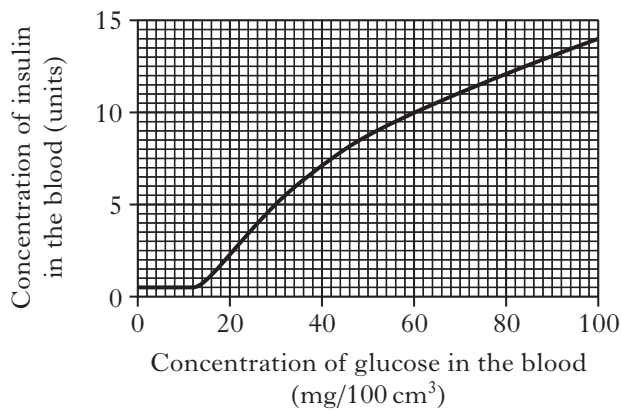

What is the total mass of glucose present in this individual's bloodstream when the concentration of insulin in the blood was 5 units?

- A 30 mg
- B 150 mg
- C 300 mg
- D 1500 mg

26. Carbohydrate is stored in the liver as

- A glucagon
- B glucose
- C glycogen
- D starch.

27. Changes in the body temperature of mammals are detected by a temperature monitoring centre. This sends a signal to effectors whose action returns the temperature to a normal level.

These events are summarised in the diagram below.

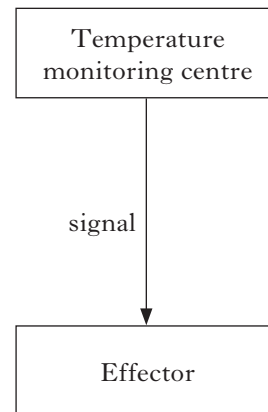

Which line in the table below identifies correctly the temperature monitoring centre, type of signal and the effector involved in this control?

	<i>Temperature monitoring centre</i>	<i>Type of signal</i>	<i>Effector</i>
A	skin	nervous	hypothalamus
B	hypothalamus	hormonal	skin
C	skin	hormonal	hypothalamus
D	hypothalamus	nervous	skin

[Turn over

28. The graph below shows the rate of sweat production in an individual human subject under different environmental conditions.

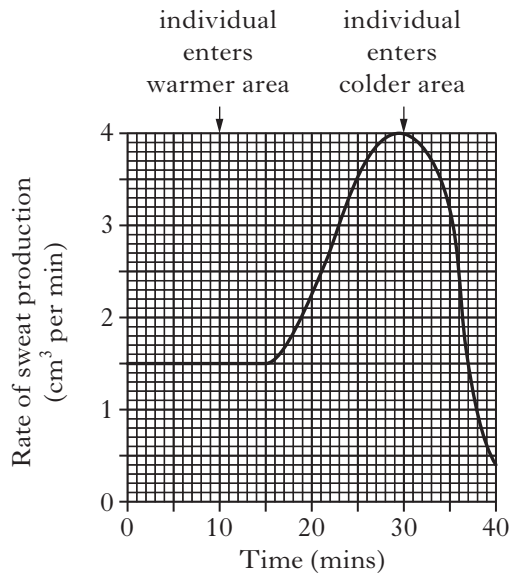

How long after entering the warmer area did it take for the individual's rate of sweat production to increase by 100%?

- A 8 minutes
- B 13 minutes
- C 20 minutes
- D 23 minutes

29. During succession in plant communities, a number of changes take place.

Which line in the table below describes some of these changes correctly?

	<i>Species diversity</i>	<i>Biomass</i>	<i>Food web complexity</i>
A	increases	increases	increases
B	increases	decreases	increases
C	decreases	increases	increases
D	increases	increases	decreases

30. The body temperatures of a reptile and a mammal were measured at different air temperatures. Which graph below illustrates the results?

..... Reptile
 _____ Mammal

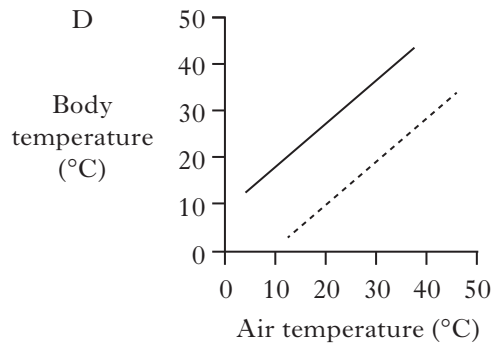
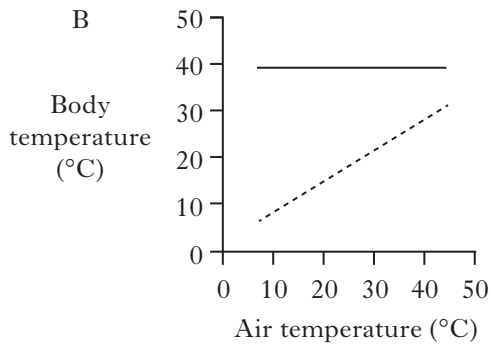
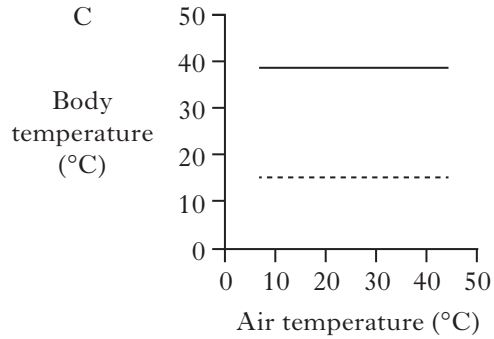
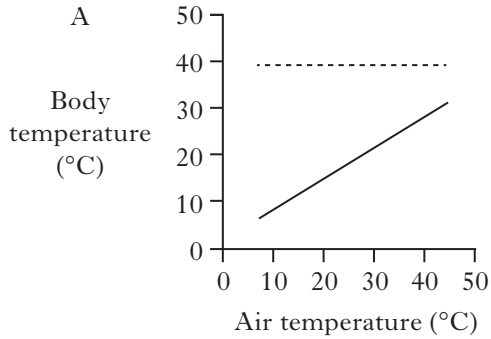

Candidates are reminded that the answer sheet MUST be returned INSIDE the front cover of this answer book.

[Turn over for Section B on *Page twelve*

SECTION B

Marks

All questions in this section should be attempted.
All answers must be written clearly and legibly in ink.

1. The diagram below shows a magnified view of an animal cell.

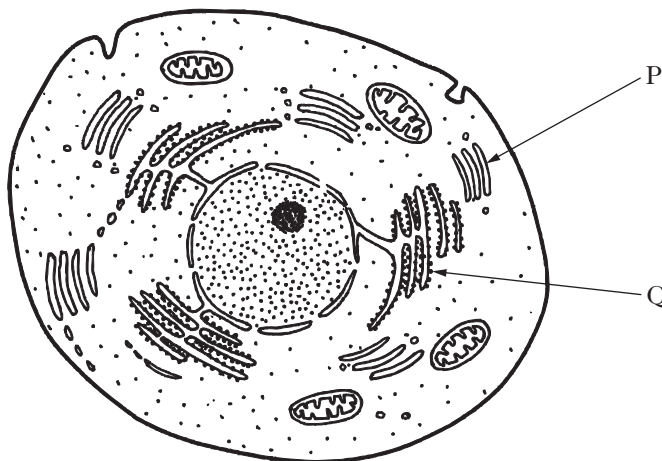

(a) Identify organelles P and Q.

P _____

Q _____

1

(b) (i) Glycolysis is the first stage in cellular respiration and involves a net gain of ATP.

Explain what is meant by a net gain of ATP.

1

(ii) Complete the table below which relates to the names, locations and products of two further stages of aerobic respiration in cells.

<i>Name of stage</i>	<i>Location of stage</i>	<i>Products of stage</i>
Krebs cycle		carbon dioxide, hydrogen and ATP
	cristae of mitochondria	

2

(iii) Describe the role of NAD in aerobic respiration.

1

Marks

2. The table below shows the rate of potassium ion uptake by animal cells growing in culture solutions with different oxygen concentrations.

<i>Oxygen concentration</i> (%)	<i>Rate of potassium ion uptake by animal cells</i> (units per minute)
0	2
1	24
2	42
3	58
4	65
5	65

- (a) Describe the effect of increasing oxygen concentration on the uptake of potassium ions by the cells.

2

- (b) Calculate how many units of potassium ions the animal cells would take up in one hour at an oxygen concentration of 1%.

Space for calculation

_____ units

1

- (c) Explain the low rate of potassium ion uptake by the cells at 0% oxygen.

2

[Turn over

Marks

3. The diagram below shows molecules in the plasma membrane.

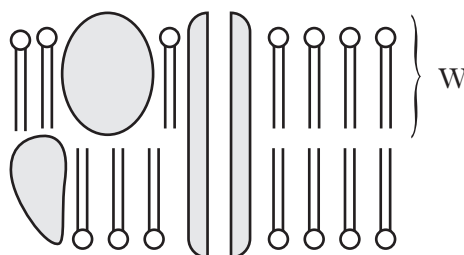

(a) Name molecule W.

1

(b) Complete the following sentence by underlining one of the alternatives in each pair to make the sentence correct.

When a cell with a membrane of the type shown above is placed in a hypertonic solution, water molecules will move $\left\{ \begin{array}{l} \text{into} \\ \text{out of} \end{array} \right\}$ the cell by $\left\{ \begin{array}{l} \text{osmosis} \\ \text{active transport} \end{array} \right\}$.

1

(c) The diagram below shows a stage in the synthesis of a membrane protein in a cell.

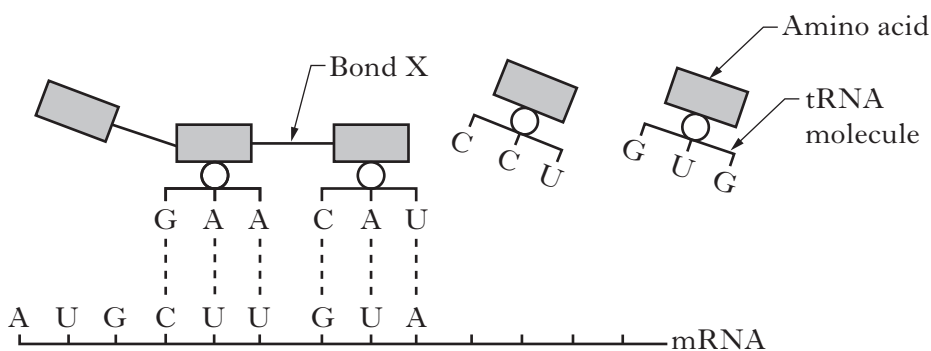

(i) Name a region of DNA which codes for a protein.

1

(ii) Name bond X.

1

(iii) Identify the stage of protein synthesis shown in the diagram.

1

Marks

3. (c) (continued)

- (iv) Explain how tRNA is involved in the assembly of the correct sequence of amino acids in the protein.

2

[Turn over

Marks

4. Adenovirus can cause respiratory infections in humans.

The diagram below shows a single adenovirus and the flow chart outlines some stages in the infection of a human cell by this virus.

Diagram

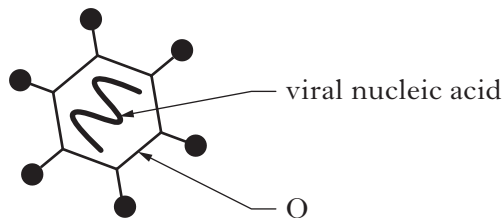

Flow chart

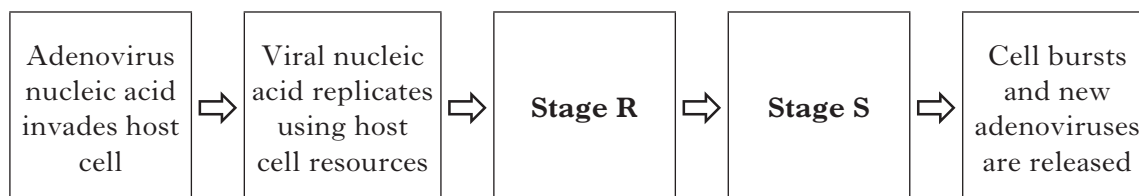

(a) (i) Name the substance of which structure Q is composed.

1

(ii) Give **two** resources supplied by the host cell which are needed for the replication of the viral nucleic acid.

1 _____

2 _____

2

(iii) Describe what happens at Stages R and S in the flow chart.

R _____

1

S _____

1

Marks

4. (a) (continued)

(iv) In response to adenovirus, white blood cells produce specific antibodies.

1 Name the white blood cells that produce antibodies.

1

2 Give the term used to describe substances which stimulate the production of specific antibodies.

1

(b) Name the substance that some plants use to protect themselves against the spread of infection from injured areas.

1

[Turn over

Marks

5. Photosynthesis in algal cells can be measured by immersing them in bicarbonate indicator solution. The indicator solution gradually changes colour as carbon dioxide is removed from it by photosynthesis. This colour change can be measured by placing the solution in a colorimeter. The higher the rate of photosynthesis, the higher the reading on the colorimeter.

The effect of different wavelengths of light on rate of photosynthesis in *Scenedesmus*, an alga which grows near the surface of fresh water lochs, was measured. The apparatus shown below was set up in a darkened room.

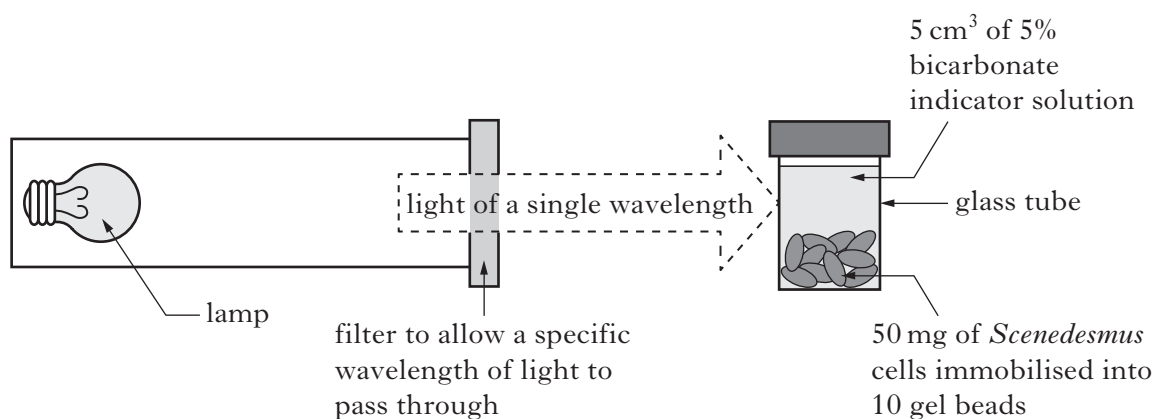

After one hour, the bicarbonate indicator was removed from the tube, placed in a colorimeter and a reading taken.

The experiment was carried out seven times using filters, each of which allowed different wavelengths of light to pass through.

The results are shown in the table below.

<i>Filter</i>	<i>Wavelength of light passing through (nanometres)</i>	<i>Colorimeter reading (units)</i>
1	400	0.48
2	450	0.74
3	500	0.36
4	550	0.32
5	600	0.24
6	650	0.96
7	700	0.26

- (a) Identify **two** variables, not already mentioned, that would have to be controlled to ensure that the experimental procedure was valid.

1 _____

2 _____

2

5. (continued)

Marks

- (b) A control tube would be required for each wavelength of light being investigated.

Describe the contents of a suitable control tube.

1

- (c) State why the tubes were left for one hour before the colorimeter readings were taken.

1

- (d) (i) On the grid provided, draw a line graph to show the colorimeter readings against wavelength of light.

(Additional graph paper, should it be required, will be found on Page forty.)

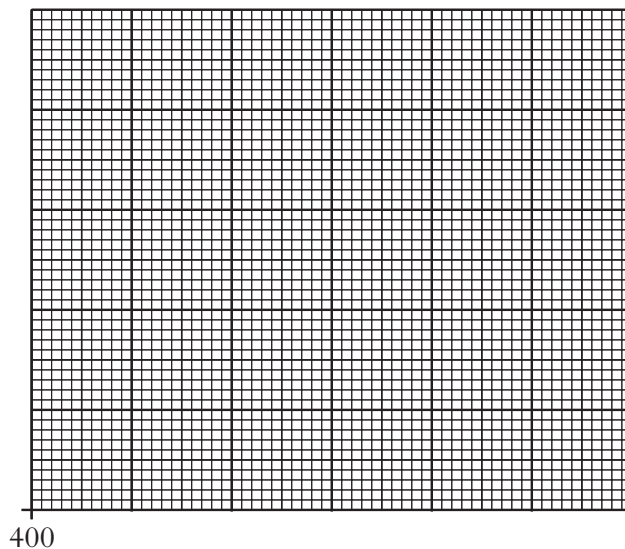

400

Wavelength of light (nanometres)

2

- (ii) Give the reason why the graph of colorimeter reading against wavelength of light can be described as an action spectrum.

1

- (e) The experiment was repeated with a second alga which lives in the water below *Scenedesmus*.

Predict the colorimeter reading the indicator would give after exposure of the second alga to light of 500 nanometres and explain your answer.

Prediction _____ units

1

Explanation _____

1

Marks

6. (a) A flowering plant species has a diploid chromosome number of 14.

Complete the table below to show the number of chromosomes present in the nuclei of cell types in this plant.

<i>Cell type</i>	<i>Number of chromosomes present in cell nuclei</i>
root hair cell	
gamete mother cell	
gamete	

2

- (b) The diagram below shows a cell from a different flowering plant species.

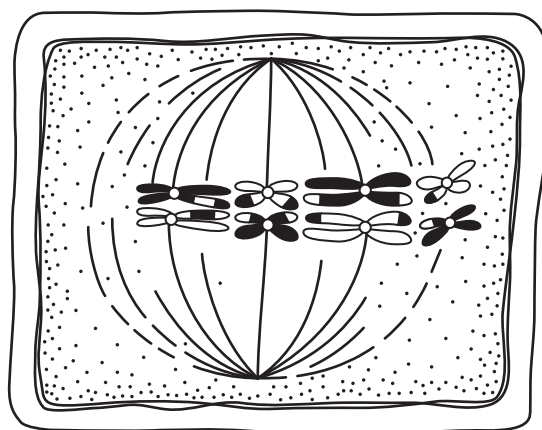

- (i) Identify **two** features shown in diagram which indicate that this cell is dividing by meiosis.

1 _____

2 _____

2

- (ii) Name an organ of a flowering plant in which meiosis takes place.

1

Marks

7. (a) Red-green colour deficiency is caused by a mutation in the gene coding for one of the proteins needed for normal colour vision. The allele for red-green colour deficiency (**r**) is sex-linked and recessive to the normal allele (**R**).

The diagram below shows the inheritance of red-green colour deficiency in a family.

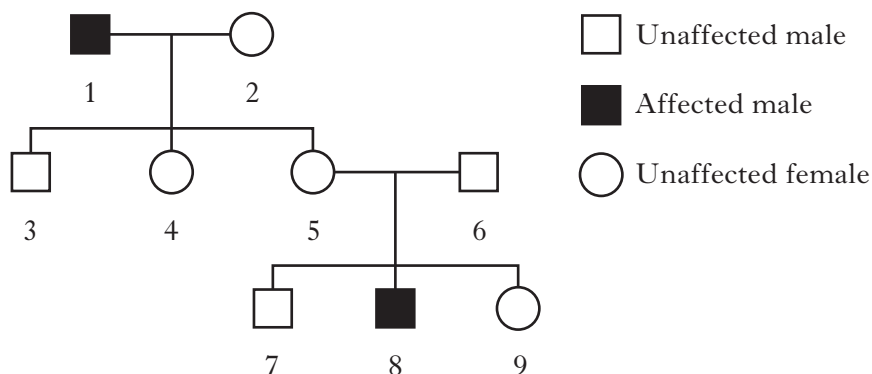

- (i) Give the term used to describe a female who is heterozygous for a recessive sex-linked characteristic.

1

- (ii) Calculate the percentage chance that the **daughter of individuals 5 and 6** would be heterozygous for red-green colour deficiency.

Space for calculation

_____ %

1

- (iii) Explain why males are more likely to be affected by recessive sex-linked conditions than females.

1

- (b) Name **two** types of gene mutation.

1 _____

2 _____

1

[Turn over

Marks

8. In North America, moose are hunted by packs of grey wolves. The numbers of moose and wolves present in a National Park were monitored over a 40 year period and the results are shown in the graph below.

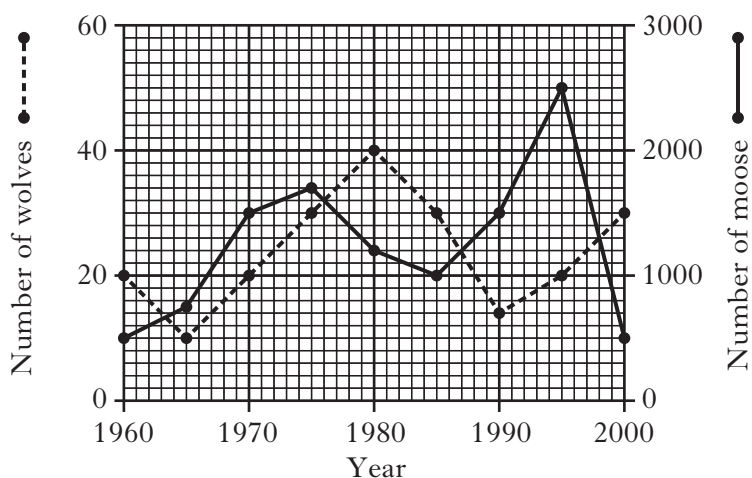

- (a) (i) Calculate the number of years in which the wolf population was 20 or less during the monitoring period.

Space for calculation

_____ years **1**

- (ii) Calculate the average yearly increase in the number of moose between 1960 and 1975.

Space for calculation

_____ per year **1**

- (iii) Express the number of moose to the number of wolves in 1995 as a simple whole number ratio.

Space for calculation

_____ : _____ **1**
moose wolves

- (b) Give **one** advantage to wolves of cooperative hunting.

_____ **1**

- (c) Wolves live in social groups which demonstrate a dominance hierarchy. State the meaning of the term dominance hierarchy.

_____ **1**

Marks

9. (a) The diagram below shows an open stomatal pore in the epidermis of a green plant leaf.

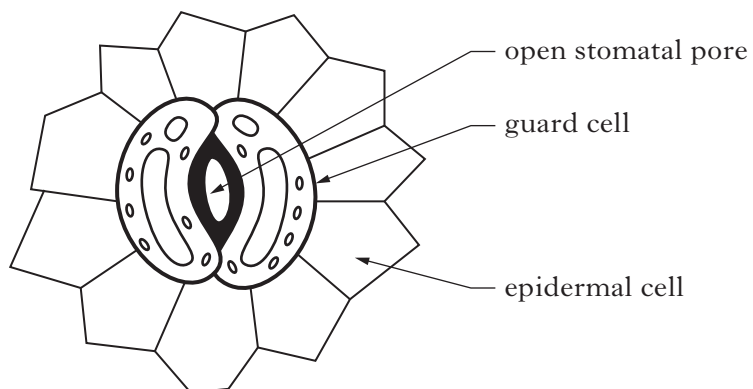

- (i) Explain how osmosis is involved in the opening of stomata.

1

- (ii) Stomata open as conditions change from dark to light.
Explain the importance of this for photosynthesis in green plants.

1

[Turn over

Marks

9. (continued)

- (b) The graph below shows the rates of transpiration from leaves of two species of green plant kept under identical environmental conditions over a six hour period.

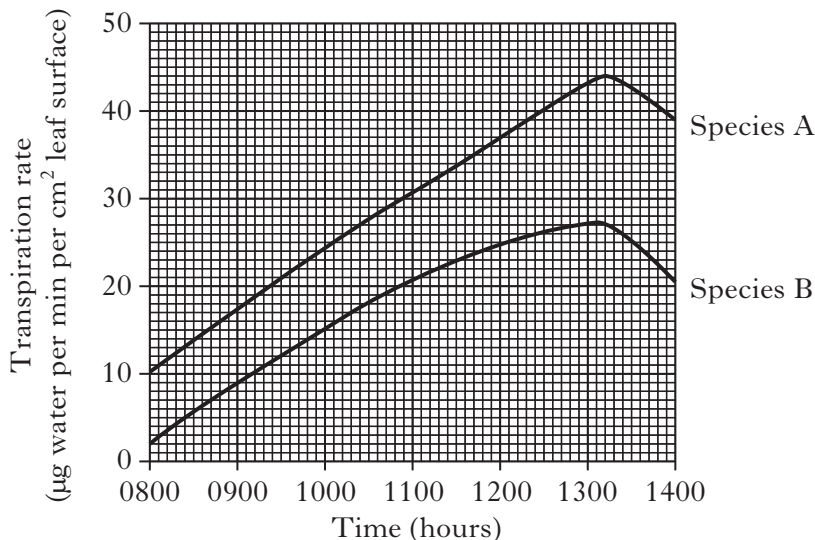

- (i) Calculate the mass of water lost per minute at 1300 hours from a leaf of species B which had a surface area of 10 cm².

Space for calculation

_____ µg per minute **1**

- (ii) Calculate the difference in rate of transpiration between species A and species B at 1100 hours.

Space for calculation

_____ µg water per min per cm² leaf surface **1**

- (iii) Explain why the units of transpiration used allowed a valid comparison of transpiration rate between the two species.

_____ **1**

- (c) Give **one** benefit of transpiration to plants.

_____ **1**

Marks

10. The peppered moth *Biston betularia* is predated by small birds which find them resting on the surfaces of walls and trees. These surfaces can be darkened by air pollution.

The diagram below shows light and melanic varieties of the peppered moth resting on the surface of a tree not darkened by pollution.

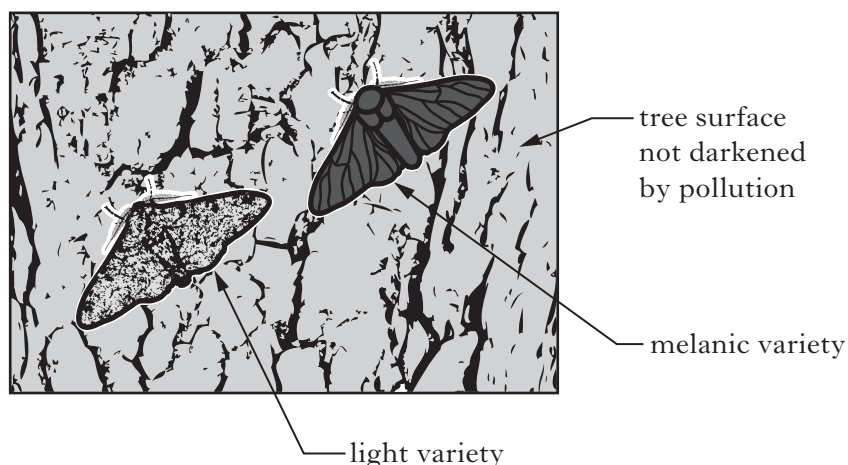

An investigation to measure the percentages of the two varieties in moth populations from an unpolluted rural area and a polluted industrial area was carried out and the results shown in the table below.

Area	Percentages in populations	
	Light variety	Melanic variety
Unpolluted rural	94	6
Polluted industrial	14	86

- (a) Explain the results for the polluted industrial area in terms of natural selection.

2

- (b) The two varieties of the peppered moth remain members of the same species. Describe evidence which would confirm this statement.

1

[Turn over

Marks

11. Alfalfa is a crop plant often grown for cattle food.

In an investigation, alfalfa was grown in six plots each of which had been treated with a different level of phosphate fertiliser. The alfalfa was harvested after 24 weeks of growth and the total dry mass of the crop at each fertiliser level was calculated. The protein content of the alfalfa grown at each fertiliser level was also determined.

The results are shown in the graph below.

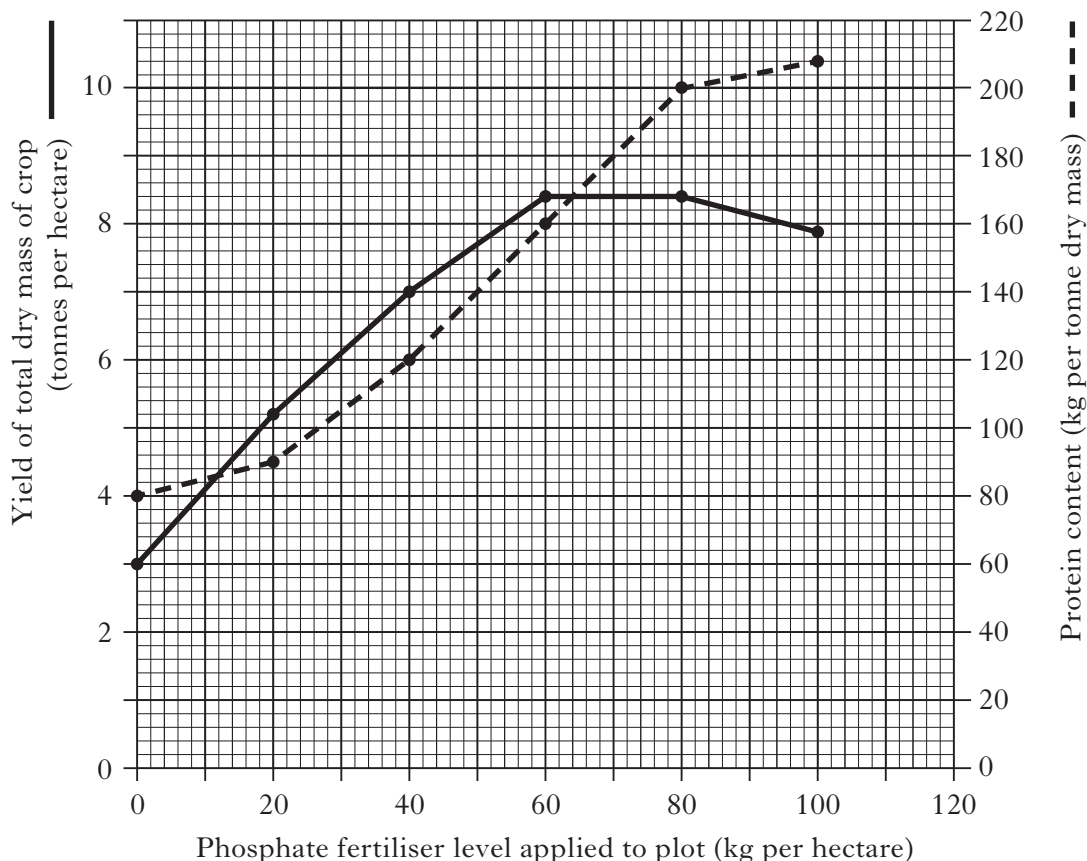

- (a) (i) Use values from the graph to describe the changes in the yield of total dry mass of the crop as the phosphate fertiliser level was increased from 0 to 100 kg per hectare.

2

- (ii) Predict the protein content of an alfalfa crop if 120 kg of phosphate fertiliser per hectare had been applied.

_____ kg per tonne dry mass

1

Marks

11. (a) (continued)

- (iii) Calculate the total mass of protein produced from one hectare when 40 kg of phosphate fertiliser per hectare was applied.

Space for calculation

_____ kg **1**

- (b) In a feeding trial, three groups of 10 cattle were fed with alfalfa of different protein contents over a 25 day period. The cattle were weighed at the beginning and end of this period and the average increase in their body mass calculated.

The results are shown in the table below.

<i>Cattle group</i>	<i>Protein content of alfalfa fed to cattle (kg per tonne dry mass)</i>	<i>Average increase in body mass of cattle over a 25 day period (kg)</i>
1	80	12
2	90	15
3	120	17

- (i) State how the design of the feeding trial ensured the reliability of the results.

_____ **1**

- (ii) Using the information in the **table**, calculate the average increase in mass per day of the cattle in Group 2.

Space for calculation

_____ kg per day **1**

- (iii) Using information from the **graph and table**:

- 1 suggest the phosphate fertiliser level which was applied in the production of the alfalfa which the cattle in Group 2 were fed;

_____ kg per hectare **1**

- 2 draw a conclusion about how phosphate fertiliser levels applied to alfalfa affected the growth of cattle in the feeding trial.

_____ **1**

- (c) Explain the effect of the increase in the level of phosphate fertiliser applied on the protein content of alfalfa grown.

_____ **1**

Marks

12. The diameters of xylem vessels were measured in two regions, P and Q, of a woody stem.

The percentages of vessels in different diameter ranges was calculated for each region and the results are shown in the table below.

Range of diameter of xylem vessels (micrometres)	Percentage of xylem vessels (%)	
	Region P	Region Q
1–20	32	0
21–40	50	4
41–60	16	23
61–80	2	41
81–100	0	32

(a) Calculate the total percentage of vessels in region Q with diameters greater than 40 micrometres.

Space for calculation

_____ % **1**

(b) The diagram below shows part of a section through the same woody stem.

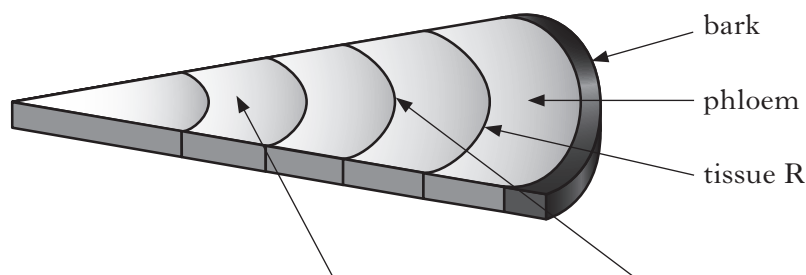

Regions		
Season in which xylem vessels formed		

Complete the grid above by adding the letters to the boxes to identify regions P and Q, and the season during which the vessels in these regions were formed.

2

(c) Name tissue R shown in the section and state its function.

Name _____

Function _____

2

Marks

13. The diagrams below show a potato plant tuber before and after the breaking of its bud dormancy.

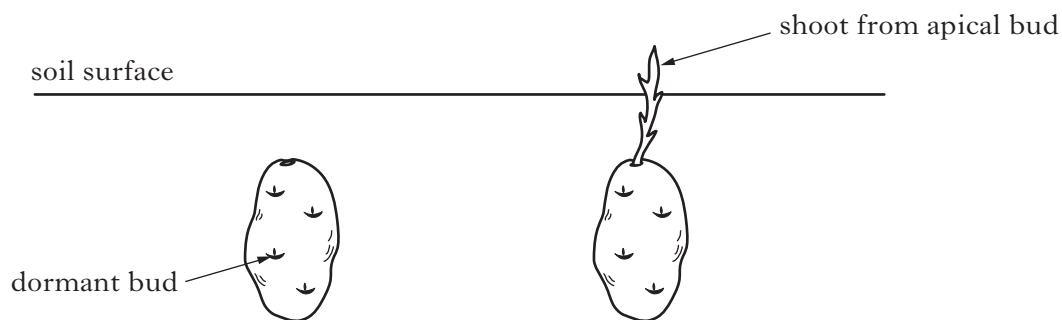

Diagram 1
Potato tuber with
dormant buds

Diagram 2
Potato tuber after
bud dormancy broken

- (a) Name the plant growth substance responsible for breaking bud dormancy.

1

- (b) The shoot in **Diagram 2** demonstrates apical dominance.

- (i) Describe how information in the diagram supports this statement.

1

- (ii) Give an advantage to the potato plant of apical dominance.

1

[Turn over

Marks

14. Water voles are an endangered species native to Scotland. American mink are predatory animals which escaped from captivity and have become established in water vole habitats.

In an investigation into the effects of mink on water vole populations, the presence of each species was recorded at sample sites along a river each week for a ten week period. The entire population of resident mink was removed from this river after week 2 of the investigation.

The results are shown in the table below.

<i>Week of investigation</i>	<i>Percentage of sample sites where each species was found (%)</i>	
	<i>American mink</i>	<i>Water vole</i>
0 (start)	35	2
2	40	1
4	0	5
6	0	16
8	0	30
10	0	42

- (a) (i) Give evidence from the table which suggests that mink are predators of water voles.

1

- (ii) In week 6, water voles were found at 20 of the sample sites.
Calculate the number of sample sites involved in the investigation.

Space for calculation

_____ sites

1

- (iii) Other than predation, give a density dependent factor which could influence the water vole population.

1

Marks

14. (a) (continued)

(iv) The flow chart below shows an outline of the action of a density dependent factor on the water vole population.

Complete **Box 2** and **Box 3** by adding one of the following to make the flow chart correct.

increases *decreases* *stays the same*

Each answer may be used once, twice or not at all.

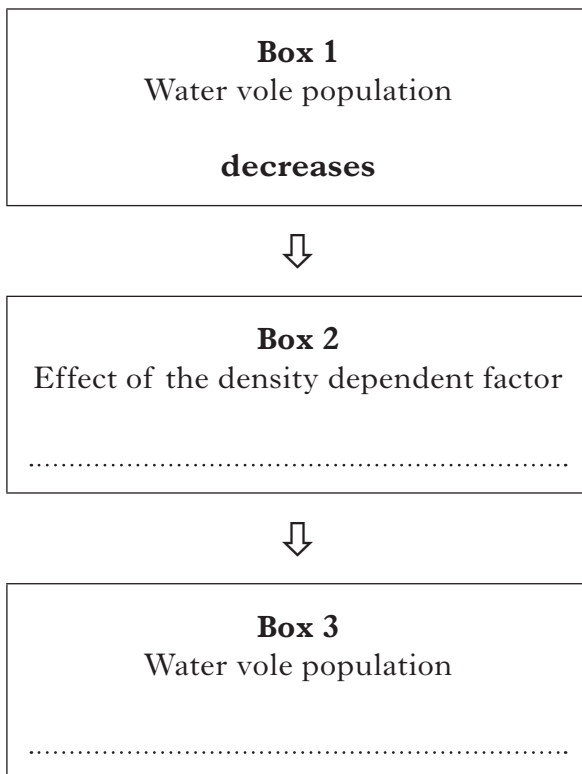

2

(b) Populations of endangered species are monitored to give essential data which can be used in their conservation.

Give **one** other reason for monitoring wild populations.

1

[Turn over for Section C on Page thirty-two

SECTION C

Marks

Both questions in this section should be attempted.

Note that this section contains a choice.

Questions 1 and 2 should be attempted on the blank pages which follow.

Supplementary sheets, if required, may be obtained from the Invigilator.

All answers must be written clearly and legibly in ink.

Labelled diagrams may be used where appropriate.

1. Answer **either A or B**.

A. Write notes on factors controlling growth and development under the following headings:

(i) nitrogen and magnesium in plants; 6

(ii) vitamin D, calcium and iron in mammals. 4

OR

(10)

B. Write notes on genetic control of metabolism under the following headings:

(i) phenylketonuria in humans; 3

(ii) control of lactose metabolism in *Escherichia coli*. 7

(10)

In question 2, ONE mark is available for coherence and ONE mark is available for relevance.

2. Answer **either A or B**.

A. Give an account of genetic engineering in bacteria and somatic fusion in plants. (10)

OR

B. Give an account of the problems of osmoregulation faced by **salt water** bony fish and outline their adaptations to overcome these problems. (10)

[END OF QUESTION PAPER]

SPACE FOR ANSWERS

--	--

SPACE FOR ANSWERS

--	--

SPACE FOR ANSWERS

--	--

SPACE FOR ANSWERS

--	--

SPACE FOR ANSWERS

--	--

SPACE FOR ANSWERS

--	--

SPACE FOR ANSWERS

--	--

SPACE FOR ANSWERS

ADDITIONAL GRAPH PAPER FOR QUESTION 5 (*d*)

