

**CHEMISTRY**

Higher Grade—PAPER I

Tuesday, 10th May—9.30 a.m. to 11.00 a.m.

**READ CAREFULLY**

1. Check that the answer sheet provided is for Chemistry Higher I.
2. Fill in the details required on the answer sheet.
3. In this paper a question is answered by indicating the choice A, B, C or D (or E in the case of questions 49 and 50) by a stroke made in INK in the appropriate place in the answer sheet—see the sample question below.
4. For each question choose ONE answer which you think is correct.
5. Reference may be made to the booklets of Mathematical Tables and Science Data provided (1982 editions).
6. Rough working, if required, should be done only on this question paper, or on the rough working sheet provided—NOT on the answer sheet.

**SAMPLE QUESTION**

To show that the ink in a ball-point pen consists of a mixture of dyes the method of separation would be

- A fractional distillation
- B chromatography
- C fractional crystallisation
- D filtration.

The correct answer is **B**—chromatography. A heavy vertical line should be drawn joining the two dots in the appropriate box in the column headed **B** as shown in the example on the answer sheet.

If after you have recorded your answer you decide that you have made an error and wish to make a change you should cancel the original answer and put a vertical stroke in the box you now consider to be correct. Thus if you want to change an answer **D** to an answer **B** your answer sheet would look like this:

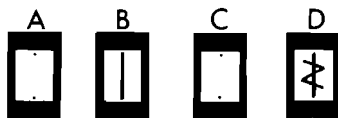

If you want to change back to an answer which has already been scored out you should enter a tick (✓) to the RIGHT of the box of your choice, thus:

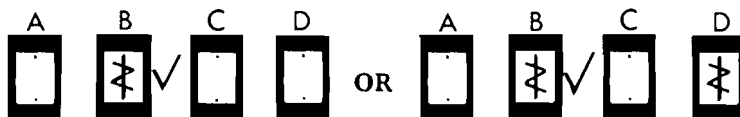

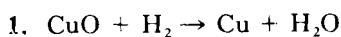

From the equation it is possible to deduce

- A the conditions necessary for the reaction to take place
- B the rate at which the reaction takes place
- C the mechanism by which the reaction proceeds
- D the relative quantities of each reactant and product.

2.

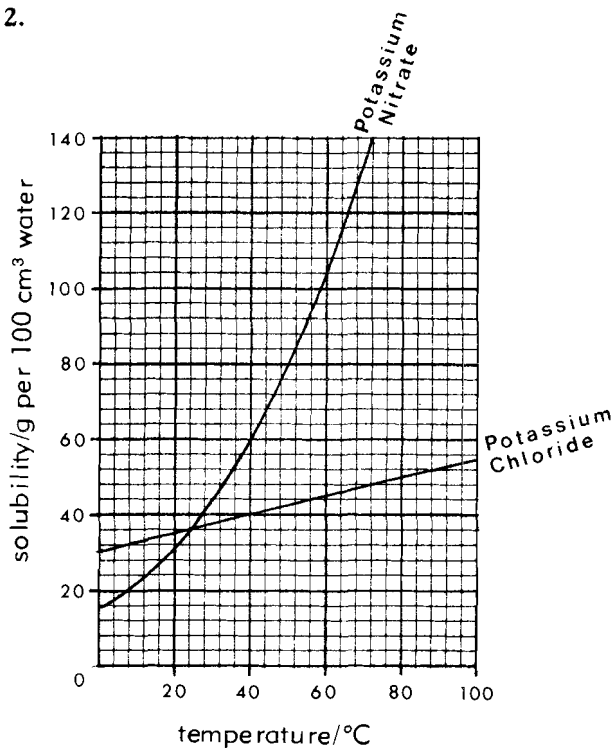

A mixture of 50 g potassium nitrate and 50 g potassium chloride is added to 100 cm<sup>3</sup> water. Which of the following is likely to happen when this is heated to 60 °C and thoroughly stirred?

- A All the solid will dissolve.
- B Some potassium nitrate will remain undissolved.
- C Some potassium chloride will remain undissolved.
- D Some potassium nitrate and some potassium chloride will remain undissolved.

3.

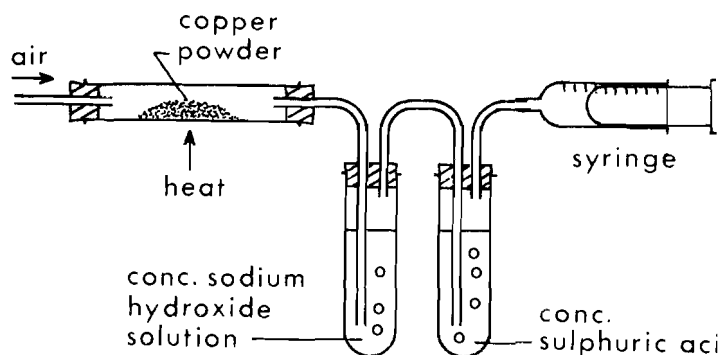

The above apparatus was set up to prepare nitrogen from air, but the gas collected was not pure.

Which of the following impurities would have been present?

- A Carbon dioxide
- B Sulphur dioxide
- C Water vapour
- D Noble gases

4. Copper carbonate is precipitated when solutions of copper(II) sulphate and sodium carbonate are mixed.

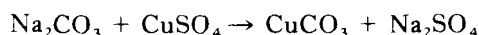

Which of the following mixtures would give the greatest mass of precipitate?

- A 1.5 cm<sup>3</sup> M Na<sub>2</sub>CO<sub>3</sub> + 0.5 cm<sup>3</sup> M CuSO<sub>4</sub>
- B 0.5 cm<sup>3</sup> M Na<sub>2</sub>CO<sub>3</sub> + 1.5 cm<sup>3</sup> M CuSO<sub>4</sub>
- C 1.0 cm<sup>3</sup> M Na<sub>2</sub>CO<sub>3</sub> + 1.0 cm<sup>3</sup> M CuSO<sub>4</sub>
- D 2.0 cm<sup>3</sup> M Na<sub>2</sub>CO<sub>3</sub> + 0.5 cm<sup>3</sup> M CuSO<sub>4</sub>

5. A mixture of sodium sulphate and copper(II) sulphate is known to contain 3 moles of sulphate ions and 1 mole of copper ions.

How many moles of sodium ions are present?

- A 1
- B 2
- C 3
- D 4

6. An element is a diatomic gas with a density of 1.25 grams per litre at s.t.p.

Which of the following calculations gives the relative atomic mass (atomic weight) of the element?

- A  $1.25 \times 22.4$   
B  $1.25 \times 22.4 \times 2$   
C  $\frac{1.25 \times 22.4}{2}$   
D  $\frac{1.25 \times 1000}{22.4 \times 2}$
7. Which process is used for the industrial extraction of aluminium?
- A Electrolysis of an aqueous solution of  $\text{Al}^{3+}$   
B Electrolysis of a melt containing aluminium oxide  
C Heating aluminium oxide with coke  
D Adding scrap iron to an aqueous solution of  $\text{Al}^{3+}$
8. Electrolysing molar aqueous solutions of the chlorides listed below gave the following products at one of the electrodes. (**Assume comparable conditions in each case.**)

Compound	Product
Sodium chloride	Hydrogen
Magnesium chloride	Hydrogen
Aluminium chloride	Hydrogen
Copper chloride	Copper

Which of the following conclusions can be made from the information given?

- A Copper ions accept electrons more readily than do hydrogen ions.  
B Copper chloride causes least ionisation of water.  
C Copper chloride is the most ionic compound.  
D Copper ions are the most mobile.

9. In which of the following reactions is the hydrogen ion an oxidising agent?

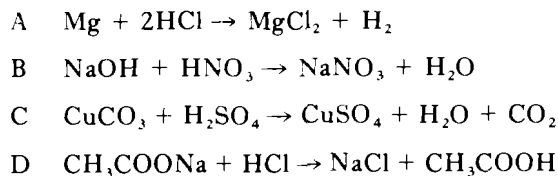

10. When a 1 M aqueous solution is diluted its conductivity decreases but its pH remains constant.

The solution could be

- A ethanoic acid  
B sodium chloride  
C sodium hydroxide  
D nitric acid.

11. Which of the following statements about carbon monoxide is **false**?

- A It is the main constituent of natural gas.  
B It is a reducing agent.  
C It reacts with haemoglobin in blood more readily than does oxygen.  
D It can be formed by the reduction of carbon dioxide.

12. In which case below is the **first-named chemical** a catalyst in the process described?

- A Copper(II) oxide in the conversion of carbon monoxide to carbon dioxide  
B Iron in the manufacture of ammonia  
C Magnesium in the protection of iron from corrosion  
D Sodium hydroxide solution in the manufacture of soap

[Turn over

Questions 13 and 14 refer to the following.

When the substances listed below react together state whether the substance underlined acts as

- A a base
- B a reducing agent
- C an oxidising agent
- D an acid only.

13. Concentrated sulphuric acid and carbon

14. Copper(II) oxide and dilute sulphuric acid

15. The action of digestive enzymes on proteins in food is an example of

- A hydrolysis
- B hydrogenation
- C dehydration
- D dehydrogenation.

16. A solution of potassium carbonate, made up using tap water, was found to be cloudy.

This could result from the tap water containing

- A sodium ions
- B chloride ions
- C magnesium ions
- D sulphate ions.

17. In which line of the table are fat, protein and soap correctly classified?

	<i>Polymers</i>	<i>Salts</i>	<i>Esters</i>
A	Fat	Soap	Protein
B	Fat	Protein	Soap
C	Soap	Fat	Protein
D	Protein	Soap	Fat

18. Which of the following substances would evolve an alkaline gas when heated with soda-lime?

- A Starch
- B Cotton
- C Wool
- D Paper

19. Polypropylene (polypropene) is

- A a synthetic condensation polymer
- B a synthetic addition polymer
- C a natural condensation polymer
- D a natural addition polymer.

20. Which of the following causes the separation of the ions in a mass spectrometer?

- A A vacuum pump
- B A discharge tube
- C An ionisation chamber
- D A magnetic field

21. 1. [ $^1\text{H}_2^{16}\text{O}$ ] $^+$     2. [ $^1\text{H}_2^{17}\text{O}$ ] $^+$     3. [ $^1\text{H}_2^{18}\text{O}$ ] $^+$   
4. [ $^2\text{H}_2^{16}\text{O}$ ] $^+$     5. [ $^2\text{H}_2^{17}\text{O}$ ] $^+$     6. [ $^2\text{H}_2^{18}\text{O}$ ] $^+$

Which of the following pairs of ions will be indistinguishable in a mass spectrum?

- A 1 and 4
- B 2 and 5
- C 3 and 6
- D 3 and 4

22.  $^{24}_{11}\text{Na}$  is a  $\beta$ -emitter with a half-life of 15 hours. If a sample of pure  $^{24}_{11}\text{Na}$  weighs 1.00 mg, what will the sample weigh after 120 hours?

- A 1.00 mg
- B 0.25 mg
- C 0.125 mg
- D 0.012 mg

23. How much charge is required to deposit half a mole of nickel atoms from nickel(II) sulphate solution?

- A 0.5 F
- B 1.0 F
- C 1.5 F
- D 2.0 F

24. A mixture of 60 cm<sup>3</sup> hydrogen and 40 cm<sup>3</sup> carbon monoxide is passed over excess of heated copper(II) oxide until no further reaction occurs.

What is the volume of the remaining gas? (All volumes are measured at s.t.p.)

- A 0 cm<sup>3</sup>
- B 40 cm<sup>3</sup>
- C 60 cm<sup>3</sup>
- D 100 cm<sup>3</sup>

25. From the table of electrode potentials on page 6 of the Data Book which of the following cells would have the highest e.m.f.?

- A Zn | Zn<sup>2+</sup> || Ag<sup>+</sup> | Ag
- B Mg | Mg<sup>2+</sup> || Al<sup>3+</sup> | Al
- C Al | Al<sup>3+</sup> || Fe<sup>2+</sup> | Fe
- D Fe | Fe<sup>3+</sup> || Cu<sup>2+</sup> | Cu

26. Which of the following would produce a blue-black colour when added to a solution containing starch and potassium iodide?

- A Bromine water
- B Dilute sulphuric acid
- C Sodium hydroxide solution
- D Iron(II) sulphate solution

27.

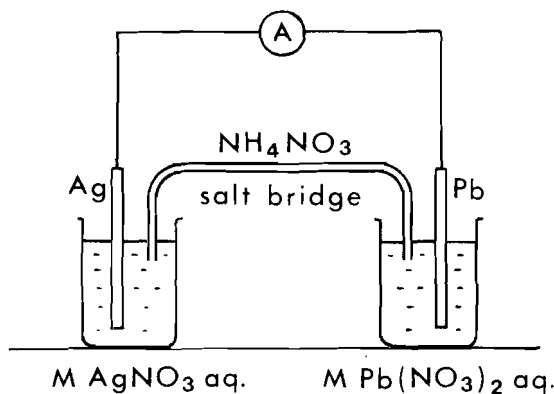

Which of the following occurs in the above cell?

- A The mass of the lead electrode increases.
- B Oxidation takes place at the silver electrode.
- C The molarity of the lead(II) nitrate solution increases.
- D Electrons flow from silver to lead through the meter.

28. Which of the following hydrides, when added to water, would give the most acidic solution?

- A Sodium hydride
- B Magnesium hydride
- C Silicon hydride
- D Sulphur hydride

29. A white solid dissolves in water giving an alkaline solution, and reacts with dilute hydrochloric acid giving off a gas.

The solid could be

- A copper(II) ethanoate
- B potassium carbonate
- C ammonium chloride
- D calcium carbonate.

30. Which of the following would be the best conductor of electricity?

- A Solid sodium
- B Solid sodium chloride
- C Aqueous sodium chloride
- D Gaseous chlorine

31. In which of the following will the halogen molecule be reduced?
- A  $\text{Br}_2(\text{aq}) + \text{I}^-(\text{aq})$   
 B  $\text{I}_2(\text{aq}) + \text{Br}^-(\text{aq})$   
 C  $\text{Cl}_2(\text{aq}) + \text{F}^-(\text{aq})$   
 D  $\text{I}_2(\text{aq}) + \text{Cl}^-(\text{aq})$
32. A pupil obtained a certain volume of carbon dioxide by the action of  $20 \text{ cm}^3$  2 M hydrochloric acid on excess of sodium carbonate.  
 Which one of the following reagents gives the same final volume of carbon dioxide when added to excess sodium carbonate?
- A  $20 \text{ cm}^3$  4 M hydrochloric acid  
 B  $10 \text{ cm}^3$  4 M hydrochloric acid  
 C  $20 \text{ cm}^3$  2 M sulphuric acid  
 D  $40 \text{ cm}^3$  2 M hydrochloric acid
33. A filter paper was dipped into a solution of phosphorus in carbon disulphide. After the carbon disulphide had evaporated, the filter paper caught fire. (A filter paper dipped into pure carbon disulphide does not catch fire.)  
 This indicates that
- A the burning of phosphorus has a negative activation energy  
 B the evaporation of the carbon disulphide provides the activation energy for the burning of the phosphorus  
 C the activation energy for the burning of the phosphorus is attainable at room temperature  
 D phosphorus provides activation energy for the evaporation of the carbon disulphide.
34.  $\text{H}_2(\text{g}) + \text{I}_2(\text{g}) \rightleftharpoons 2\text{HI}(\text{g})$   
 The activation energy for the forward reaction is  $181.5 \text{ kJ}$  and for the reverse reaction is  $192.8 \text{ kJ}$ .  
 What is the enthalpy (heat) of formation of  $2\text{HI}(\text{g})$ ?
- A  $+ 11.3 \text{ kJ}$   
 B  $- 11.3 \text{ kJ}$   
 C  $+ 374.3 \text{ kJ}$   
 D  $- 374.3 \text{ kJ}$
35. Manganese dioxide speeds up the decomposition of hydrogen peroxide because it
- A increases the enthalpy change  
 B decreases the enthalpy change  
 C increases the energy of activation  
 D decreases the energy of activation.
36. In reversible reactions the position of equilibrium is influenced by
- A particle size  
 B collision geometry  
 C catalytic action  
 D temperature change.
37. For which of the following reactions will change of pressure have **no** effect on the concentrations of reactants and products at equilibrium?
- A  $\text{N}_2(\text{g}) + 3\text{H}_2(\text{g}) \rightleftharpoons 2\text{NH}_3(\text{g})$   
 B  $\text{N}_2\text{O}_4(\text{g}) \rightleftharpoons 2\text{NO}_2(\text{g})$   
 C  $\text{H}_2(\text{g}) + \text{I}_2(\text{g}) \rightleftharpoons 2\text{HI}(\text{g})$   
 D  $2\text{SO}_2(\text{g}) + \text{O}_2(\text{g}) \rightleftharpoons 2\text{SO}_3(\text{g})$
38. The equilibrium yield of  $\text{SO}_3(\text{g})$  for the reaction  

$$2\text{SO}_2(\text{g}) + \text{O}_2(\text{g}) \rightleftharpoons 2\text{SO}_3(\text{g})$$
 at  $700 \text{ }^\circ\text{C}$  is 40%. In the presence of a catalyst this yield would be
- A increased and attained more rapidly  
 B increased and attained in the same time  
 C unchanged but attained more rapidly  
 D decreased but attained more rapidly.
39. When aqueous solutions of silver nitrate and iron(II) sulphate are mixed, a deposit of silver is formed and an equilibrium set up:  

$$\text{Ag}^+ + \text{Fe}^{2+} \rightleftharpoons \text{Ag} + \text{Fe}^{3+}$$
 Which of the following, when added to the equilibrium mixture, would increase the mass of silver deposited?
- A Sulphuric acid  
 B Iron(III) sulphate  
 C Iron(III) nitrate  
 D Silver nitrate

40. A pH value greater than 7 would be shown by a 1.0 M solution of

- A potassium sulphate
- B ammonium chloride
- C sodium ethanoate
- D lithium chloride.

41. Which of the following is an aldehyde?

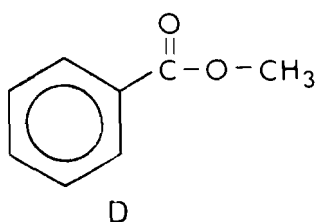
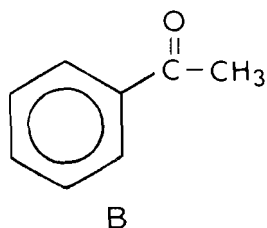
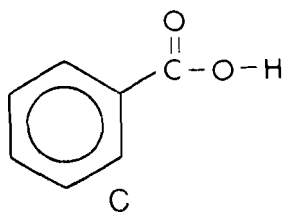
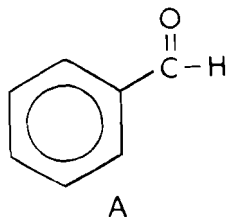

42. Which of the following is an isomer of hexene?

- A 2,2-dimethylbutane
- B 2-methylbut-1-ene
- C 2,4-dimethylpent-2-ene
- D cyclohexane

43. Ethane is formed by

- A polymerisation of methane
- B dehydration of ethanol
- C hydrolysis of ethyl ethanoate
- D hydrogenation of ethene.

Questions 44 and 45 refer to the following:

- A It has formula C<sub>6</sub>H<sub>12</sub>.
- B It behaves towards bromine water as if saturated.
- C It can be formed by dehydrating cyclohexanol.
- D It is miscible with water.

44. Which is true of benzene?

45. Which is true of hex-1-ene?

46. Which of the following are produced by hydrolysis of proteins?

- A Simple sugars
- B Glycerol and carboxylic acids
- C Amino acids
- D None of these

Questions 47 and 48 refer to the experiment illustrated below.

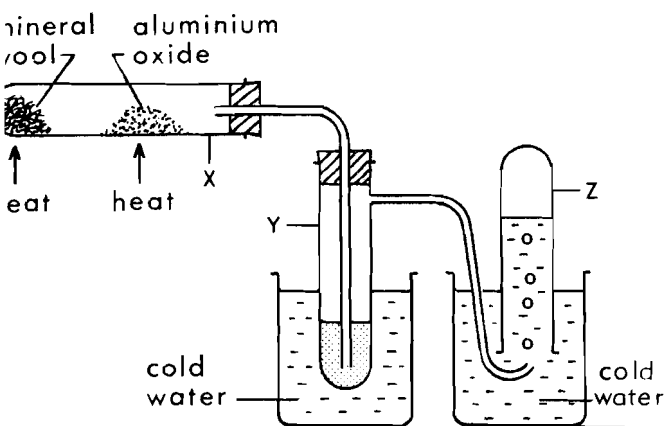

In the above experiment the mineral wool was soaked with propan-1-ol. Its vapour was passed over red-hot aluminium oxide.

47. The reaction taking place in tube X is an example of
- condensation
  - dehydration
  - dehydrogenation
  - reduction.
48. Any traces of gas Z dissolved in the liquid in Y are removed. What effect would bromine water have on the purified liquid in Y and on the gas in Z?
- Both Y and Z would react.
  - Y would react and Z would not.
  - Z would react and Y would not.
  - Neither Y nor Z would react.

In questions 49 and 50 more than one response may be correct.

Answer

- if responses 1, 2 and 3 are correct
- if responses 1 and 3 are correct
- if responses 2 and 4 are correct
- if response 4 only is correct
- if some other response or combination of responses is correct.

49. The reaction between chlorine and ethane to give chloroethane is a chain reaction.

Which of the following reactions will be "chain-stopping" (i.e. will not propagate the chain)?

- $C_2H_6 + Cl\cdot \rightarrow C_2H_5\cdot + HCl$
- $C_2H_5\cdot + Cl\cdot \rightarrow C_2H_5Cl$
- $C_2H_5\cdot + Cl_2 \rightarrow C_2H_5Cl + Cl\cdot$
- $C_2H_5\cdot + C_2H_5\cdot \rightarrow C_4H_{10}$

50. An excess of silver nitrate solution is added to a solution of sodium chloride, and a white precipitate is formed. After filtering which, if any, of the following reagents would give a precipitate when added to the filtrate? (It may be helpful to consult the table on page 11 of the Data Book.)

- Barium chloride
- Potassium nitrate
- Calcium hydroxide
- Sodium fluoride

[END OF QUESTION PAPER]



[92/237]

1983

SCOTTISH CERTIFICATE OF EDUCATION

# CHEMISTRY

Higher Grade—PAPER II

Tuesday, 10th May—1.30 p.m. to 4.00 p.m.

**Marks may be deducted for bad spelling and bad punctuation, and for writing that is difficult to read.**

**Working should be shown in all answers involving calculations.**

**Necessary tables and data will be found in the booklets of Mathematical Tables and Science Data (1982 editions).**

**PART A**

All questions should be attempted. It should be noted, however, that some questions contain a choice.

It is suggested that about one hour be spent on this part of the paper.

*Marks*

1. Find values for a, b, c, d, and e to balance the equation:
- $$a\text{C}_3\text{H}_5(\text{NO}_3)_3 \rightarrow b\text{CO}_2 + c\text{H}_2\text{O} + d\text{N}_2 + e\text{O}_2 \quad (2)$$
2. Answer **EITHER A OR B**.
- A. Give the name and structural formula of the organic product obtained by hydrolysing 2-bromopropane. (2)
- OR**
- B. Give the name and structural formula of the organic product obtained by warming methanol with propanoic acid in the presence of concentrated sulphuric acid. (2)
3. The mass of a pure dry nickel crucible decreased by 0.0059 g during an experiment. How many nickel atoms had it lost? (2)
4. Solutions of the salt potassium cyanide (KCN) are alkaline.
- (a) What is the formula of the acid from which potassium cyanide is derived? 1
- (b) Is it a strong or a weak acid? 1
- (c) Explain fully why potassium cyanide solution is alkaline. 3
- (5)**
5. The following is a list of ten compounds to be classified:
- potassium nitrate, phosphorus(V) oxide (phosphorus pentoxide), barium sulphate, sulphur dioxide, sodium chloride, copper(II) oxide, ethylamine, calcium oxide, aluminium oxide, benzene.

Draw a table, with the headings set out as below, and list each compound in the correct column.

<i>Soluble in water</i>			<i>Insoluble</i>
pH < 7	pH = 7	pH > 7	

**(5)**

6. A weighed sample of copper powder, contaminated with copper(II) oxide, is analysed to find the percentage of uncombined copper.
- (a) Which aqueous reagent could be used to dissolve the copper(II) oxide but not the copper? 1
- (b) What would be observed on warming the sample with this reagent? 1
- (c) Describe what you would do to complete the analysis and indicate briefly how you would calculate the result. 3
- (5)**
7. 50 cm<sup>3</sup> nitrogen monoxide (nitric oxide) were mixed with 100 cm<sup>3</sup> oxygen. When the reaction was complete, the resulting gases were passed into water.
- (a) Write a balanced equation for the reaction between nitrogen monoxide and oxygen. 1
- (b) Calculate the total volume of the gaseous mixture after the reaction was complete, but **before** adding to water. (Assume all volume measurements at the same temperature and pressure.) 2
- (c) Calculate the final volume of the remaining gas **after** adding to water. 1
- (4)**
8. (a) P is a radio-isotope which undergoes transitions as follows:
- $$P \xrightarrow{\beta \text{ emission}} Q \xrightarrow{\beta \text{ emission}} R \xrightarrow{\alpha \text{ emission}} S$$
- If the atomic number of P is 88, and its mass number 228, what are the atomic number and mass number of isotope S? 2
- (b) In each of the following pairs, state whether or not both species have the same half-life:
- (i) 1 gram <sup>212</sup>Pb and 100 gram <sup>212</sup>Pb
- (ii) 1 gram <sup>212</sup>Pb and 1 gram <sup>212</sup>Pb<sup>2+</sup>
- (iii) 1 mole <sup>210</sup>Pb and 1 mole <sup>212</sup>Pb
- (iv) 1 mole <sup>210</sup>Pb and 1 mole <sup>210</sup>PbO 2
- (4)**
9. Calcium is manufactured by the electrolysis of molten calcium chloride.
- (a) Write an ion-electron equation for the production of calcium. 1
- (b) What mass of calcium is produced if a current of 20 A flows for 32 minutes 10 seconds? 3
- (4)**

10. Answer **EITHER A OR B.**

A.

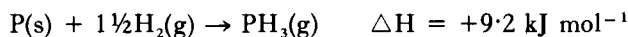

$$\text{Mean P—H bond enthalpy} = 320 \text{ kJ mol}^{-1}$$

Use the above information, together with the mean H—H bond enthalpy (Data Book, page 7) to calculate  $\Delta H_{\text{sublimation}}$  for phosphorus. **(5)**

**OR**

B.

$$\Delta H_{\text{formation}} \text{ of hydrogen sulphide gas (H}_2\text{S)} = -20.2 \text{ kJ mol}^{-1}$$



Use the above information, together with the mean H—H bond enthalpy (Data Book, page 7) to calculate the mean S—H bond enthalpy in hydrogen sulphide. **(5)**

11. Dry hydrogen chloride is passed over 23.8 g of heated tin until it is completely converted to a chloride of tin weighing 38.0 g.

Calculate the empirical (simplest) formula of the tin chloride.

(3)

12.

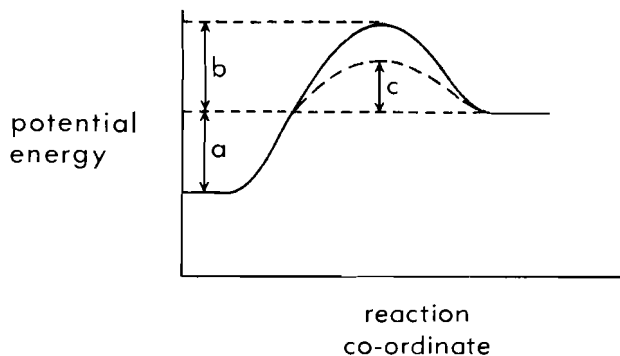

The diagram shows the energy changes involved in the uncatalysed reaction

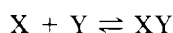

and in the (faster) catalysed reaction.

- (a) What is the value (in terms of a, b, and c) of
- the activation energy of the uncatalysed forward reaction
  - the activation energy of the catalysed reverse reaction
  - the enthalpy change for the forward reaction?
- (b) Is the forward reaction exothermic or endothermic?

3

1

(4)

13. Compound P reacts with sodium producing hydrogen gas.  
Compound P also reacts as follows:

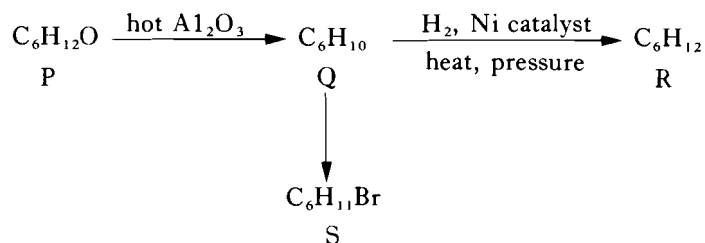

- (a) What can be deduced about the structure of P from its reaction with sodium? 1
- (b) Given that compound R does not readily undergo further addition, deduce structural formulae for P, Q, and R. 3
- (c) What reagent would be used to convert Q to S? 1

(5)

## PART B

All three questions should be attempted. Each question contains a choice.

Candidates are advised to spend about 1½ hours on this part.

Marks

### 14. Answer EITHER A OR B.

A. In a clock experiment to study reaction rates, two solutions were prepared:

#### SOLUTION 1

- 5 cm<sup>3</sup> 0.01M sodium thiosulphate solution
- 25 cm<sup>3</sup> M sulphuric acid
- 25 cm<sup>3</sup> 0.1M sodium iodide solution

#### SOLUTION 2

- 4 cm<sup>3</sup> hydrogen peroxide solution
- 6 cm<sup>3</sup> starch solution

On mixing the two solutions, nothing seemed to happen for 10 seconds and then a blue-black colour suddenly appeared.

The theory behind the experiment is as follows:

(i) Hydrogen peroxide reacts relatively slowly with iodide ions in acid solution:



The mechanism for this reaction is thought to be:

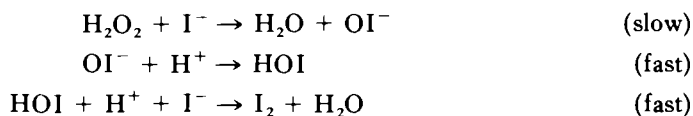

(ii) As long as any sodium thiosulphate solution remains, it rapidly reduces the iodine formed (Equation A) to iodide ions again:

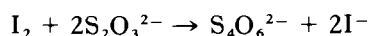

(iii) When all the sodium thiosulphate has been used up, the iodine which is still being produced reacts with the starch forming the usual blue-black colour.

(a) Why is it unlikely that the chemical reaction would proceed in one step as shown in equation A? 2

- (b) What would have happened to the time taken for the blue-black colour to appear if
- (i) 25 cm<sup>3</sup> 0.2M sodium iodide had been used instead of 25 cm<sup>3</sup> 0.1M sodium iodide?
  - (ii) 5 cm<sup>3</sup> 0.02M sodium thiosulphate had been used instead of 5 cm<sup>3</sup> 0.01M sodium thiosulphate?

**Explain your answers.** 4

(c) Name one condition which would have to be kept constant in the experiments referred to in (b) above. 1

(d) Write down the equation for the rate determining step in the reaction of hydrogen peroxide with iodide ions in acid solution. 1

(e) What would you predict would happen to the time taken for the colour to appear if the M sulphuric acid was replaced by an equal volume of 2M sulphuric acid? **Give a reason for your answer.** 2

[Turn over

The reaction between iodine and thiosulphate can also be studied in a cell.

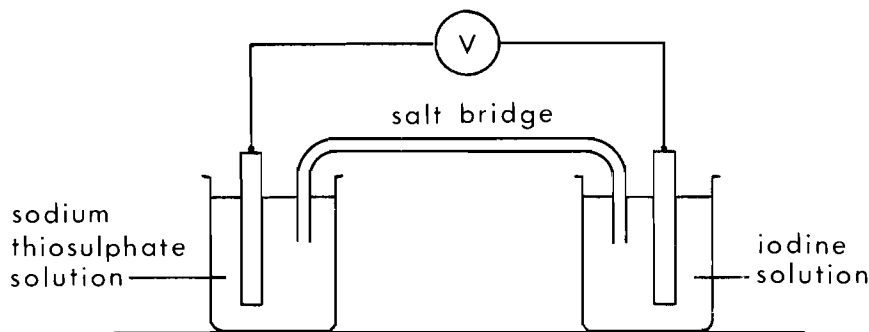

- (f) Given that  $\text{S}_4\text{O}_6^{2-}(\text{aq}) + 2\text{e}^- \rightarrow 2\text{S}_2\text{O}_3^{2-}(\text{aq})$   $E^\ominus = +0.10 \text{ V}$ , use the Data Book (page 6) to predict the e.m.f. of the above cell. 2
- (g) What assumption is made about the concentrations of the solutions in calculating this e.m.f.? 1
- (h) Suggest a suitable material for the cell electrodes to obtain this e.m.f. 1
- (i) In which direction will electrons flow through the meter? 1
- (j) Explain what will happen to the colour of the iodine solution if the cell is allowed to operate for some time. 2
- (17)**

**OR**

B. An aldehyde (alkanal) can be prepared by oxidation of the corresponding alcohol (alkanol). Aldehydes themselves are easily oxidised, and this makes it difficult to stop the oxidation of an alcohol at the aldehyde stage.

One way to avoid this difficulty is catalytic dehydrogenation over hot copper. Another way is to use the fact that aldehydes generally have lower boiling points than the corresponding alcohols. For example, when an acidified dichromate solution is added dropwise to boiling ethanol, ethanal is formed at a temperature far above its boiling point. Before it can oxidise further, it escapes from the reaction mixture.

- (a) Name the alcohol you would use to prepare propanal. 1
- (b) One test for aldehydes is the "silver mirror" test, where silver ions are reduced to metallic silver. To what compound would propanal be converted during this test? 1
- (c) Explain why catalytic dehydrogenation is a good method of preparing an aldehyde. In your answer, make the meaning of "dehydrogenation" clear. 3
- (d) (i) Consult the Data Book (page 10) and calculate the difference between the boiling points of ethanal and ethanol. 1
- (ii) Give an explanation for this difference in terms of structure. 2
- (e) What colour change is observed when ethanol is oxidised by acidified dichromate solution? 1

(f) Consider the following compounds:

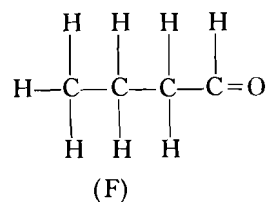
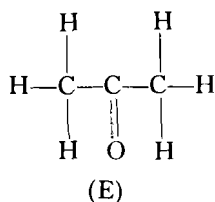
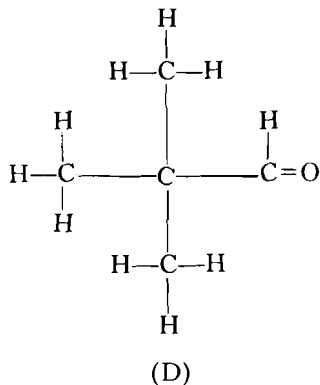
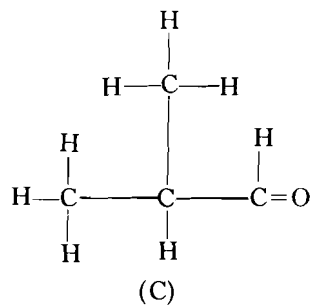
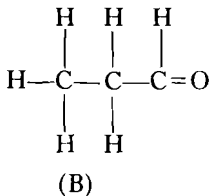
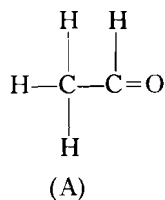

- (i) Which of the above could be oxidised to form 2-methylpropanoic acid? 1
- (ii) Which of the two compounds A or F would be more soluble in water? Give a reason for your answer. 2
- (iii) Select a pair of isomers from the above compounds. 1
- (g) A compound X is a primary alcohol, an aldehyde, or an ester. When reacted with X, hot copper(II) oxide changes colour from black to red-brown. **From this evidence alone**, what is your conclusion regarding the identity of X? 2
- (h) Although the silver mirror test is generally regarded as being a test for an aldehyde, methanoic acid gives a positive result. Suggest an explanation for this. 2
- (17)**

[Turn over

## 15. Answer EITHER A OR B.

A.

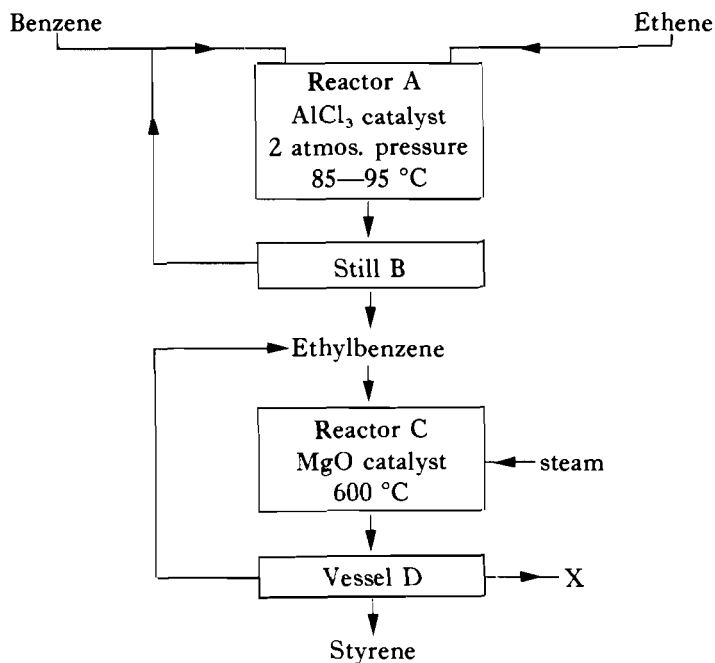

The above flow diagram shows the reaction of benzene and ethene to give ethylbenzene which is in turn converted to styrene.

The reversible reaction taking place in reactor C is:

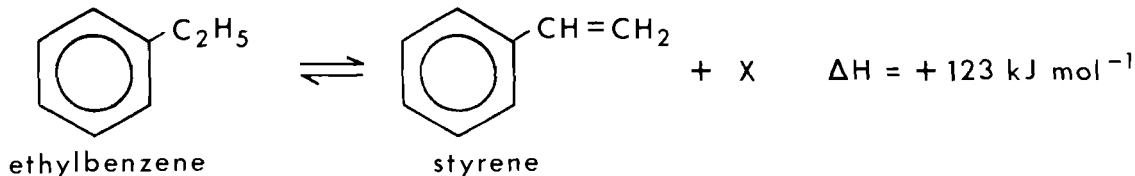

In reactor C, the ethylbenzene is mixed with steam, with which it does not react.

The steam

- (I) dilutes the system, producing the same effect on the equilibrium yield as running the reaction at low pressure;
- (II) supplies energy to the system;
- (III) converts any carbon formed as a by-product to carbon monoxide.

The conversion of ethylbenzene to styrene is about 50%, unchanged ethylbenzene being re-cycled.

- (a) Write an equation for the reaction taking place in reactor A. 2
- (b) (i) What is the mass of one mole of ethylbenzene? 3  
 (ii) Assuming 100% conversion, what mass of ethene would be required to make 530 kg of ethylbenzene? 3
- (c) What does the flow-diagram suggest about the relative proportions of benzene and ethene in the feed mixture? 1
- (d) What is product X, formed as ethylbenzene is converted to styrene? 1
- (e) Why is it that this reaction is favoured by being operated at low pressure? 2
- (f) Why is it essential to supply energy to the reaction in reactor C? 1
- (g) Write an equation for the reaction between carbon and steam. 1
- (h) Ethylbenzene boils at 136 °C and styrene at 146 °C. What process would be taking place in vessel D? 1



- (i) Draw a diagram showing how three styrene monomer units are linked together to form part of a polystyrene molecule. 2
- (j) What type of polymerisation occurs in (i) above? 1
- (k) What reagent could be used to distinguish ethylbenzene from styrene? Explain your answer. 2

(17)

**OR**

B. The diagram below illustrates some of the reactions of hydrogen:

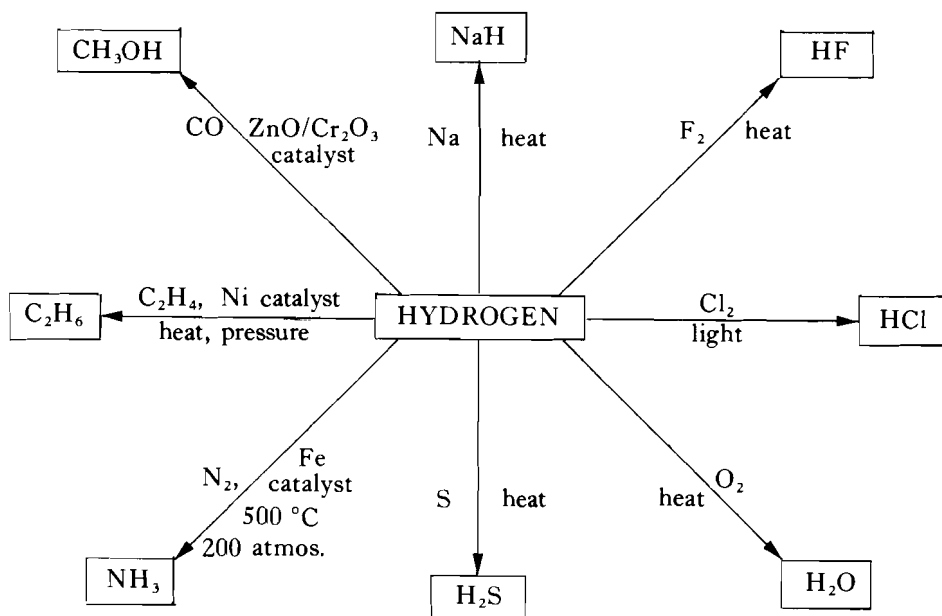

The following questions are based on the above diagram:

- (a) Name the type of chemical reaction producing ethane. 1
- (b) Which two products are basic in character? 2
- (c) In which of the above reactions is hydrogen acting as an oxidising agent? Write a pair of ion-electron equations for this reaction. 3
- (d) Hydrogen fluoride exhibits a high degree of hydrogen bonding, yet there is no such bonding in hydrogen. Explain why this is so. 3
- (e) (i) Write a balanced equation for the formation of methanol.  
(ii) Assuming that the reaction goes to completion, what mass of methanol could be made from 2 litres of hydrogen, measured at s.t.p.? 3
- (f) What role does light play in the formation of hydrogen chloride? 1
- (g) In the industrial manufacture of ammonia, some plants operate at pressures greater than 200 atmospheres. State one advantage and one disadvantage of increasing the pressure beyond 200 atmospheres. 2
- (h) Draw a diagram to show clearly the shape of a hydrogen sulphide molecule. 1
- (i) The combustion of hydrogen is exothermic. Why, then, does energy have to be supplied? 1

(17)

**[Turn over**

16. Answer **EITHER A OR B.**

Candidates are asked to pay particular attention in this question to the organisation and presentation of answers. Examiners will be marking the essay not simply to assess its scientific content, but also to give credit for the organisation and presentation of the material. In this last connection, the essential point is a due regard for normal English usage.

A. Write an essay on

The Elements of the Periodic Table—**Trends** in “Physical” Properties.

Your answer should include reference to the following:

- (a) Electron configuration.
- (b) Atomic (covalent) radius.
- (c) Ionisation energies.
- (d) Bonding in the elements.
- (e) Effect of bonding on physical properties (melting point, boiling point, electrical conductivity).

(16)

**OR**

B. Write an essay on

The “Inorganic” Chemistry of Carbon and its Compounds.

Your answer should include reference to the following:

- (a) The element carbon—polymorphs (allotropes), properties and uses.
- (b) Carbon dioxide—production, properties and uses.
- (c) Carbon monoxide—production, properties and uses.
- (d) Carbonic acid and its salts—occurrence, properties and uses.

(16)

[END OF QUESTION PAPER]