



National
Qualifications
2024

X847/76/11

**Mathematics
Paper 1 (Non-calculator)**

MONDAY, 13 MAY
9:00 AM – 10:15 AM



Total marks — 55

Attempt ALL questions.

You must NOT use a calculator.

To earn full marks you must show your working in your answers.

State the units for your answer where appropriate.

You will not earn marks for answers obtained by readings from scale drawings.

Write your answers clearly in the spaces provided in the answer booklet. The size of the space provided for an answer is not an indication of how much to write. You do not need to use all the space.

Additional space for answers is provided at the end of the answer booklet. If you use this space you must clearly identify the question number you are attempting.

Use **blue** or **black** ink.

Before leaving the examination room you must give your answer booklet to the Invigilator; if you do not, you may lose all the marks for this paper.



* X 8 4 7 7 6 1 1 *

FORMULAE LIST

Circle

The equation $x^2 + y^2 + 2gx + 2fy + c = 0$ represents a circle centre $(-g, -f)$ and radius $\sqrt{g^2 + f^2 - c}$.

The equation $(x - a)^2 + (y - b)^2 = r^2$ represents a circle centre (a, b) and radius r .

Scalar product

$\mathbf{a} \cdot \mathbf{b} = |\mathbf{a}| |\mathbf{b}| \cos \theta$, where θ is the angle between \mathbf{a} and \mathbf{b}

or $\mathbf{a} \cdot \mathbf{b} = a_1 b_1 + a_2 b_2 + a_3 b_3$ where $\mathbf{a} = \begin{pmatrix} a_1 \\ a_2 \\ a_3 \end{pmatrix}$ and $\mathbf{b} = \begin{pmatrix} b_1 \\ b_2 \\ b_3 \end{pmatrix}$.

Trigonometric formulae

$$\sin(A \pm B) = \sin A \cos B \pm \cos A \sin B$$

$$\cos(A \pm B) = \cos A \cos B \mp \sin A \sin B$$

$$\sin 2A = 2 \sin A \cos A$$

$$\cos 2A = \cos^2 A - \sin^2 A$$

$$= 2 \cos^2 A - 1$$

$$= 1 - 2 \sin^2 A$$

Table of standard derivatives

$f(x)$	$f'(x)$
$\sin ax$	$a \cos ax$
$\cos ax$	$-a \sin ax$

Table of standard integrals

$f(x)$	$\int f(x) dx$
$\sin ax$	$-\frac{1}{a} \cos ax + c$
$\cos ax$	$\frac{1}{a} \sin ax + c$

Total marks — 55
Attempt ALL questions

1. A line passes through the point $(0, 4)$ and makes an angle of 30° with the positive direction of the x -axis as shown in the diagram.

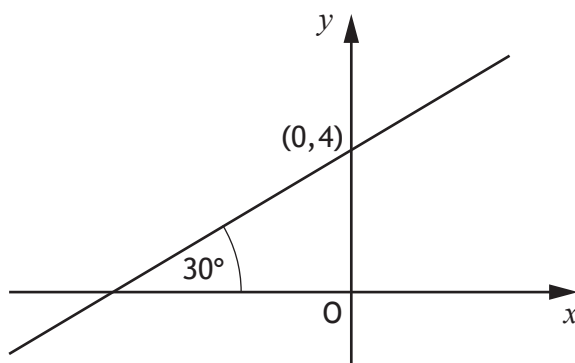

Determine the equation of the line.

3

2. A sequence is defined by the recurrence relation $u_{n+1} = \frac{1}{5}u_n + 12$ with $u_1 = 20$.

(a) Calculate the value of u_2 .

1

(b) (i) Explain why this sequence approaches a limit as $n \rightarrow \infty$.

1

(ii) Calculate this limit.

2

3. Given that $y = (5x^2 + 3)^7$, find $\frac{dy}{dx}$.

2

4. P and Q have coordinates $(-6, 1, 2)$ and $(-1, 11, -8)$ respectively.

Find the coordinates of the point R which divides PQ in the ratio 2:3.

2

[Turn over

5. A function, h , is defined by $h(x) = 2x^3 - 7$ where $x \in \mathbb{R}$.
Find the inverse function, $h^{-1}(x)$.

3

6. The right-angled triangle in the diagram is such that $\sin p = \frac{1}{\sqrt{5}}$ and $0 < p < \frac{\pi}{4}$.

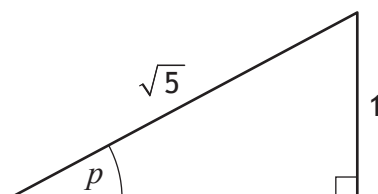

- (a) Determine the value of:

(i) $\sin 2p$

3

(ii) $\cos 2p$.

1

- (b) Hence determine the value of $\sin 4p$.

1

7. The line $y = 2x$ is a tangent to the circle with equation $x^2 + y^2 - 14x - 8y + 45 = 0$.
Determine the coordinates of the point of contact.

4

8. The equation $x^2 + (m-4)x + (2m-3) = 0$ has no real roots.

Determine the range of values for m .

4

Justify your answer.

9. Express $\log_a 5 + \log_a 80 - 2\log_a 10$ in the form $\log_a k$ where k is a positive integer. 3
10. (a) Show that $(x-1)$ is a factor of $2x^4 + 3x^3 - 4x^2 - 3x + 2$. 2
- (b) Hence, or otherwise, factorise $2x^4 + 3x^3 - 4x^2 - 3x + 2$ fully. 4
11. (a) Express $\cos x^\circ + \sqrt{3} \sin x^\circ$ in the form $k \cos(x-a)^\circ$, where $k > 0$ and $0 < a < 360$. 4
- (b) Hence, or otherwise, sketch the graph with equation $y = \cos x^\circ + \sqrt{3} \sin x^\circ$, $0 \leq x \leq 360$.
Use the diagram provided in your answer booklet. 3
12. The function f is given by $f(x) = 12\sqrt[3]{x}$, $x > 0$.
When $x = a$ the rate of change of f with respect to x is 1.
Determine the value of a . 4

[Turn over

13. P and Q are the points (4, 10) and (6, 2) respectively.

(a) Find the equation of the perpendicular bisector of PQ.

4

The point R has coordinates (12, 2).

A circle passes through the points P, Q and R.

The chord QR is horizontal.

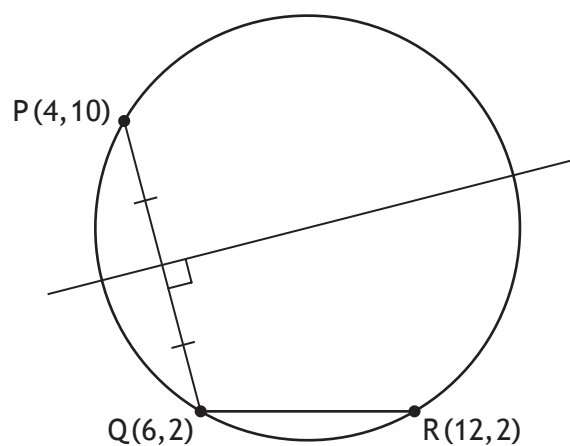

(b) Find the equation of the circle.

4

[END OF QUESTION PAPER]



National
Qualifications
2024

X847/76/12

**Mathematics
Paper 2**

MONDAY, 13 MAY
10:45 AM – 12:15 PM

Total marks — 65

Attempt ALL questions.

You may use a calculator.

To earn full marks you must show your working in your answers.

State the units for your answer where appropriate.

You will not earn marks for answers obtained by readings from scale drawings.

Write your answers clearly in the spaces provided in the answer booklet. The size of the space provided for an answer is not an indication of how much to write. You do not need to use all the space.

Additional space for answers is provided at the end of the answer booklet. If you use this space you must clearly identify the question number you are attempting.

Use **blue** or **black** ink.

Before leaving the examination room you must give your answer booklet to the Invigilator; if you do not, you may lose all the marks for this paper.



Total marks — 65
Attempt ALL questions

1. Triangle ABC has vertices A $(-3, 8)$, B $(-1, -6)$ and C $(11, 0)$.

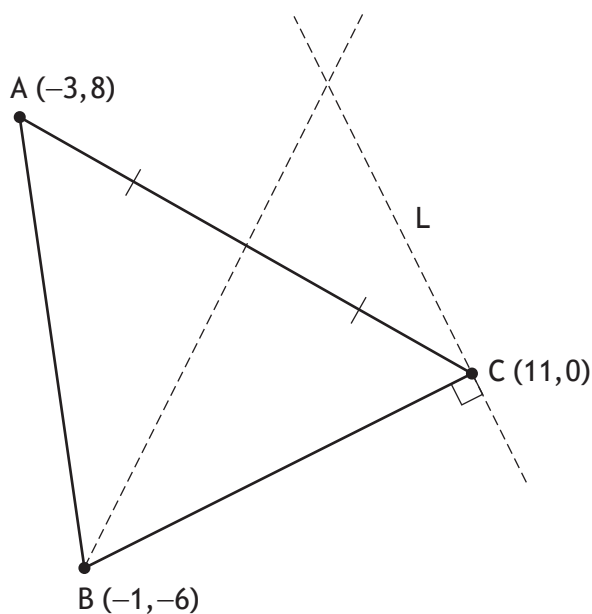

- (a) Find the equation of the median through B. 3
- (b) Find the equation of L, the line perpendicular to BC passing through C. 3
- (c) Determine the coordinates of the point of intersection of the median through B and the line L. 2
2. A curve has equation $y = \frac{8}{x^3}$, $x > 0$.
Find the equation of the tangent to this curve at the point where $x = 2$. 5

[Turn over

3. The coordinates of points D, E and F are given by D(2, -3, 4), E(1, 1, -2) and F(3, 2, 1).

- (a) Express \overline{ED} and \overline{EF} in component form. 2
- (b) (i) Calculate $\overline{ED} \cdot \overline{EF}$. 1
- (ii) Hence, or otherwise, calculate the size of angle DEF. 4

4. The diagram shows the graph of a quartic function $y = f(x)$.

A maximum turning point occurs at $(-1, 3)$.

The graph of $y = f(x)$ also has a point of inflection at $x = 2$.

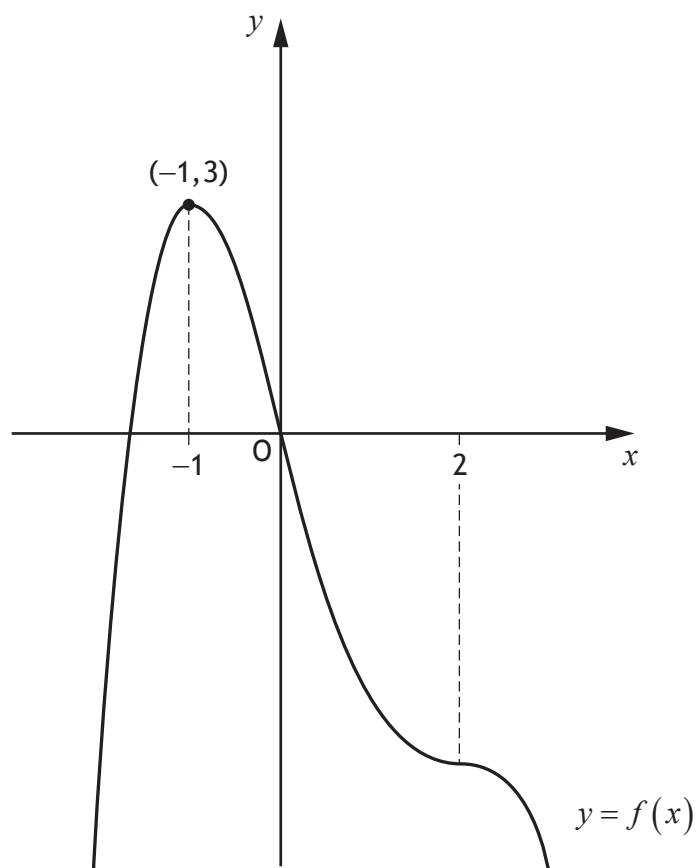

- (a) Determine the coordinates of the maximum turning point on the graph of $y = f(x-4) + 2$. 2
- (b) On the diagram in your answer booklet, sketch the graph of $y = f'(x)$. 3

5. Evaluate $\int_0^{\frac{\pi}{7}} \sin 5x \, dx$.

3

6. Two variables, x and y , are connected by the equation $y = ax^b$.
The graph of $\log_5 y$ against $\log_5 x$ is a straight line as shown.

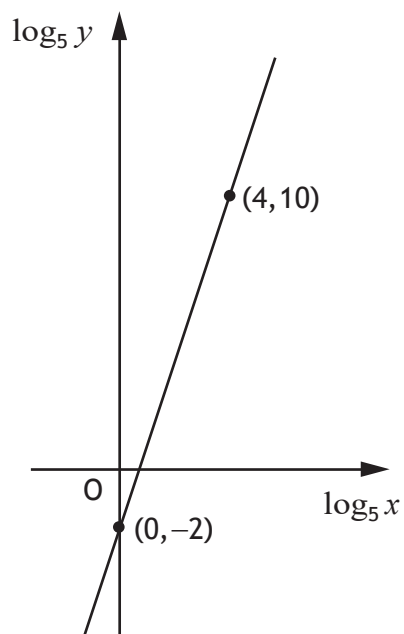

Find the values of a and b .

5

[Turn over

7. The diagram shows the curve with equation $y = x^3 - 6x^2 + 11x$ intersecting the curve with equation $y = 6 + 4x - 2x^2$ at $x = 2$.

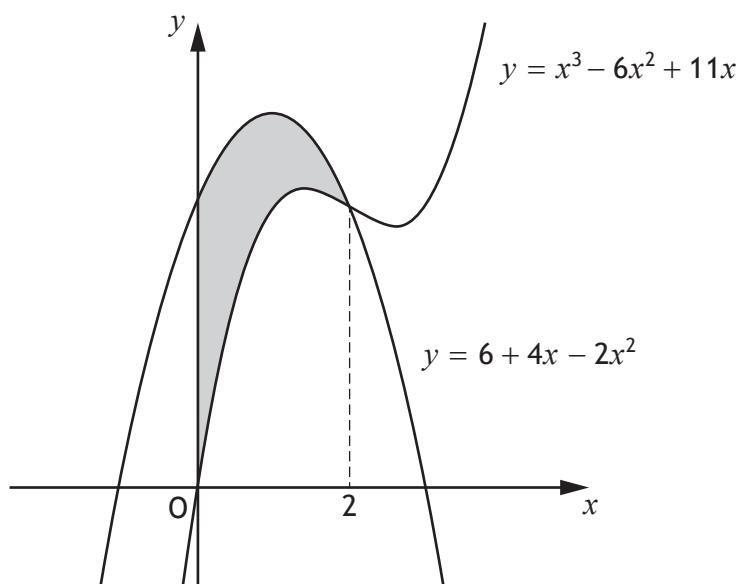

Calculate the shaded area.

5

8. Functions f and g are defined on \mathbb{R} , the set of real numbers, by:

- $f(x) = 2x^2 - 18$
- $g(x) = x + 1$.

(a) Find an expression for $f(g(x))$.

2

(b) Find the values of x for which $\frac{1}{f(g(x))}$ is undefined.

2

9. (a) Determine the coordinates of the stationary points on the curve with equation $y = \frac{1}{3}x^3 - x^2 - 3x + 1$.

4

(b) Hence, determine the greatest and least values of y in the interval $-1 \leq x \leq 6$.

2

10. The circle C_1 has equation $x^2 + y^2 + 18x - 2y - 8 = 0$.

(a) Find the centre and radius of C_1 .

2

A second circle, C_2 , touches C_1 internally.

The centre of C_2 is $(-6, 0)$.

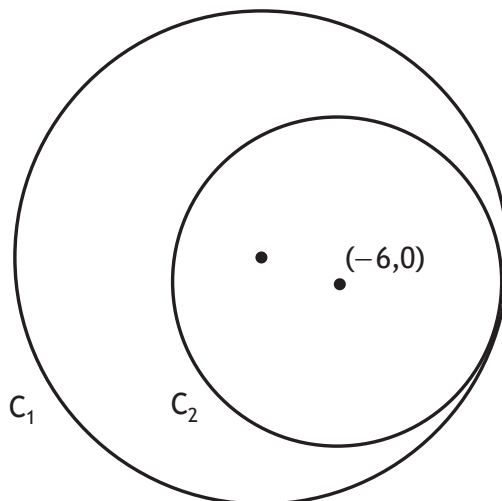

(b) Determine the equation of C_2 .

2

11. The number of electric vehicles worldwide can be modelled by

$$N = 6.8e^{kt}$$

where:

- N is the estimated number of vehicles in millions
- t is the number of years since the end of 2020
- k is a constant.

(a) Use the model to estimate the number of electric vehicles worldwide at the end of 2020.

1

At the end of 2030, it is estimated there will be 125 million electric vehicles worldwide.

(b) Determine the value of k .

4

[Turn over

12. Solve the equation $2 \sin 2x^\circ - \sin^2 x^\circ = 0$, $0 \leq x < 360$.

13. The diagram shows the graph of $y = f(x)$, where $f(x)$ is a quartic function.

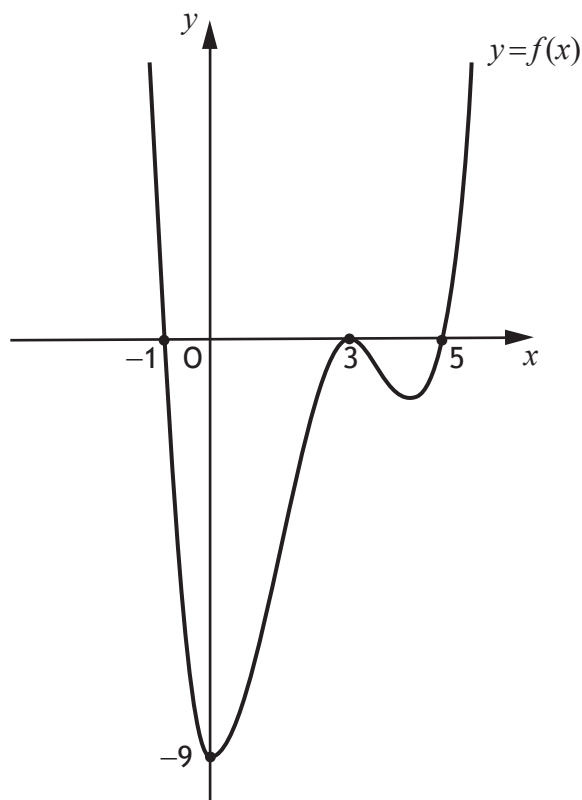

Express $f(x)$ in the form $f(x) = k(x+a)^2(x+b)(x+c)$.

3

[END OF QUESTION PAPER]