

2500/104

SCOTTISH
CERTIFICATE OF
EDUCATION
1996

THURSDAY, 9 MAY
1.30 PM – 3.45 PM

MATHEMATICS
STANDARD GRADE
Credit Level

- 1 Answer as many questions as you can.
- 2 Full credit will be given only where the solution contains appropriate working.
- 3 You may use a calculator.
- 4 Square-ruled paper is provided.



FORMULAE LIST

The roots of $ax^2 + bx + c = 0$ are $x = \frac{-b \pm \sqrt{b^2 - 4ac}}{2a}$

Sine rule: $\frac{a}{\sin A} = \frac{b}{\sin B} = \frac{c}{\sin C}$

Cosine rule: $a^2 = b^2 + c^2 - 2bc \cos A$ or $\cos A = \frac{b^2 + c^2 - a^2}{2bc}$

Area of a triangle: $\text{Area} = \frac{1}{2}ab \sin C$

1. Solve **algebraically** the inequality

$$2 + 5x \geq 8x - 16.$$

2. A ramp is being made from concrete.

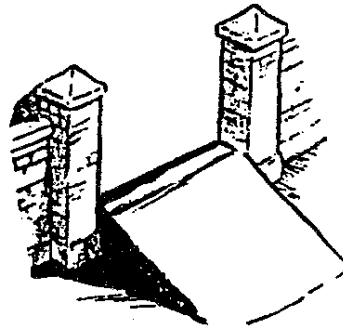

The uniform cross-section of the ramp consists of a right-angled triangle and a rectangle as shaded in the diagram below.

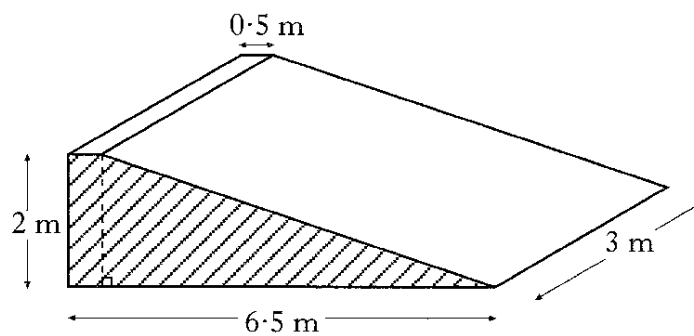

Find the volume of concrete required to make the ramp.

3. The boat on a carnival ride travels along an arc of a circle, centre C.

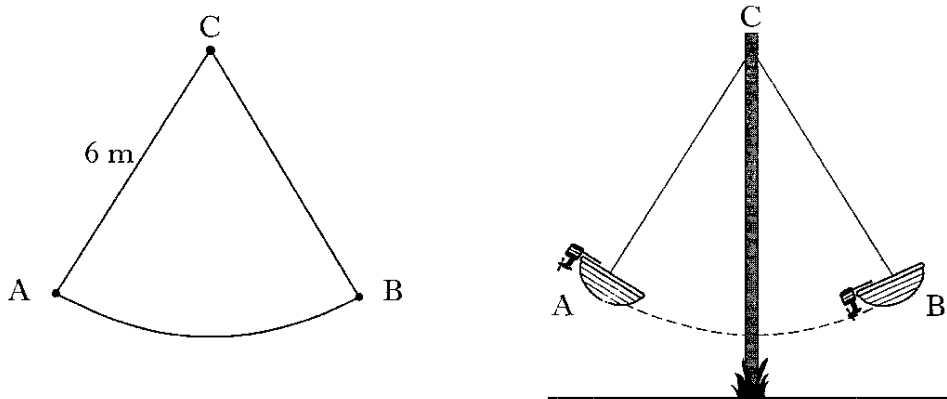

The boat is attached to C by a rod 6 metres long.

The rod swings from position CA to position CB.

The length of the arc AB is 7 metres.

Find the angle through which the rod swings from position A to position B.

KU	RA
3	
2	
4	

4. The area, A , of a quadrilateral drawn inside a circle can be found using the formula

$$A = \sqrt{(s-a)(s-b)(s-c)(s-d)},$$

where $s = \frac{(a+b+c+d)}{2}$.

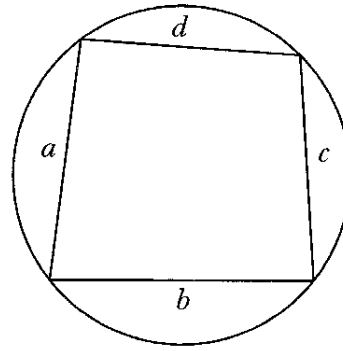

Use this formula to find the area of the quadrilateral shown in the diagram below. **Give your answer correct to 2 significant figures.**

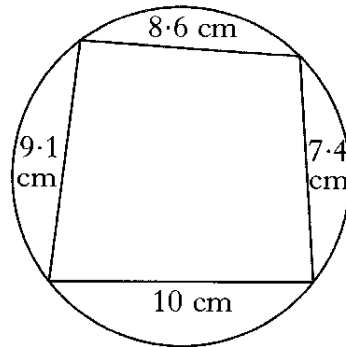

5. The travelling expenses claimed by a salesperson depend on the engine capacity of the car and the number of miles travelled per week as shown in the table below.

ENGINE CAPACITY	EXPENSES PER MILE
less than or equal to 1 litre	£0.25 for each of the first 250 miles travelled
greater than 1 litre but less than or equal to 1.2 litres	£0.27 for each of the first 250 miles travelled
greater than 1.2 litres	£0.29 for each of the first 250 miles travelled
Where the number of miles travelled in a week is greater than 250 , £0.15 can be claimed for each additional mile.	

- (a) Find the expenses claimed by a salesperson in a week when 550 miles are travelled and the engine capacity is 1.6 litres.
- (b) Write down a formula to find the expenses, £ E , claimed for t miles travelled, where t is greater than 250, and the engine capacity is 1.6 litres.

KU RA

3

2

3

6. The surface area of a planet, A square kilometres, varies directly as the square of the diameter, D kilometres, of the planet.

The surface area of the Moon is 3.8×10^7 square kilometres.

Calculate the surface area of a planet with diameter double the diameter of the Moon.

Give your answer in scientific notation.

KU	RA
3	
	1
	2

7. The graph shows the volume of petrol in a car's tank during a journey.

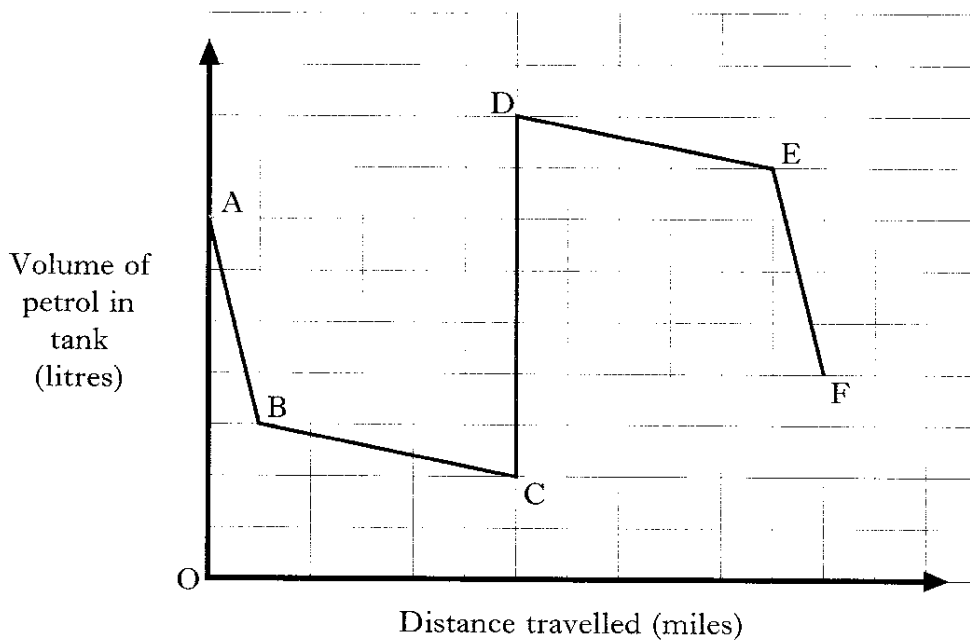

- (a) Explain the significance of CD.

The journey involves driving through towns and along motorways.

In the towns the car uses more petrol per mile than on the motorways.

- (b) Which **two** parts of the graph show driving on motorways?

Explain your answer clearly.

[Turn over

8.

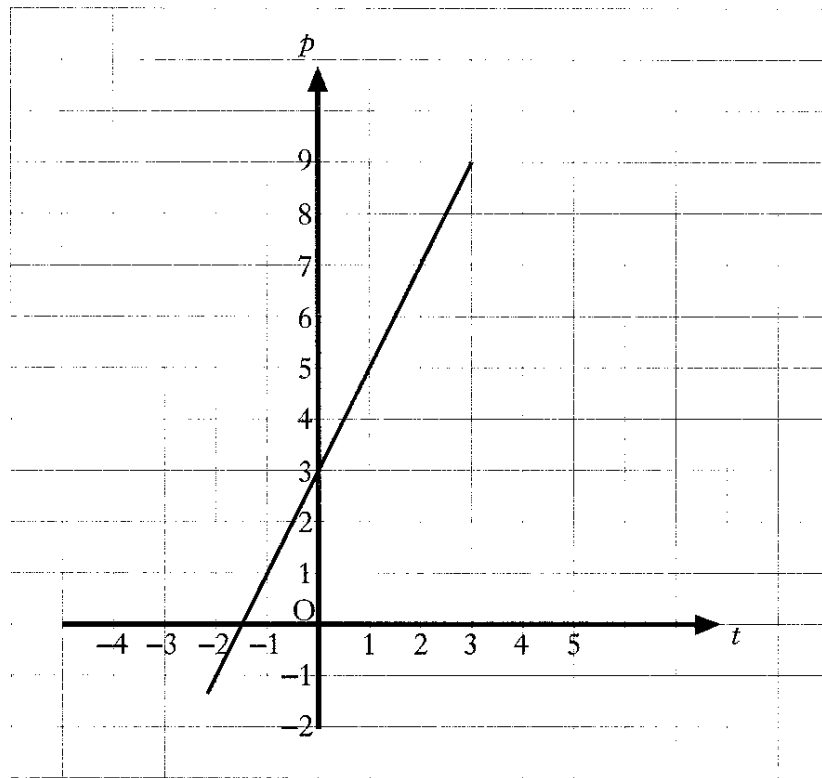

Find the equation of the straight line in terms of p and t .

KU	RA

4

9. The side wall of a house, with measurements as shown below, requires painting.

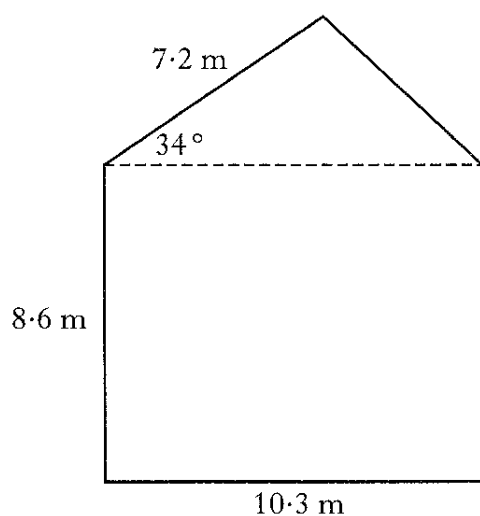

The wall is in the shape of a rectangle and a triangle.

On average, a litre of paint will cover 8 square metres.

A painter estimates that he will require 12 litres of paint.

Will this be enough paint?

Justify your answer.

10. (a) Factorise $3x^2 - 5x - 2$.

- (b) Solve **algebraically** the equation

$$\frac{m}{3} = \frac{(1-m)}{5}$$

- (c) Solve **algebraically** the equation

$$6y - y^2 = 0.$$

KU	RA
	4
2	
3	
2	

[Turn over

13. Solve **algebraically** the equation

$$5 \tan x^\circ - 9 = 0, \text{ for } 0 \leq x < 360.$$

14. The integral part of a positive real number is the part of the number which is an integer.

EXAMPLES: **The integral part of 5.6 is 5.**
 This can be written as $[5.6] = 5$.

The integral part of 6.2 is 6.
 This can be written as $[6.2] = 6$.

(a) Find $[16.7]$.

(b) Identical boxes are packed on a board for storage.

The boxes are all packed the same way round (two boxes are shown in the diagram).

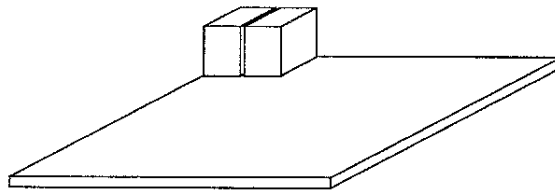

(i)

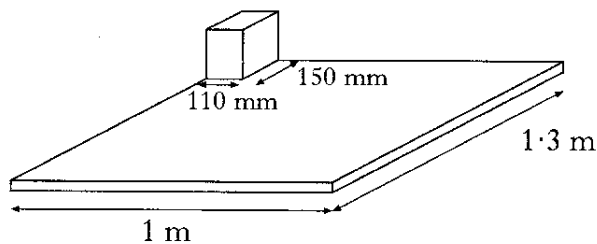

The base of each box measures 150 millimetres by 110 millimetres. The board measures 1.3 metres by 1 metre.

The number of boxes which can fit along the 1.3 metre length is given by $\left[\frac{1300}{150} \right]$.

Find $\left[\frac{1300}{150} \right]$.

(ii) Write down an expression for the number of boxes which can be packed on the board shown below.

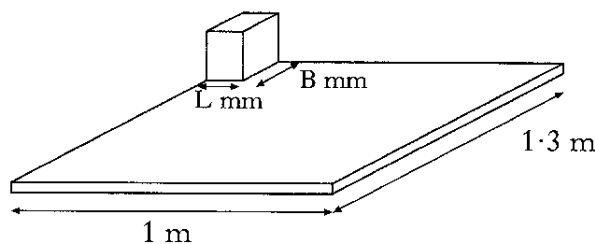

KU	RA
3	
	1
	1
	2

15. The diagram shows two positions of a student as she views the top of a tower.

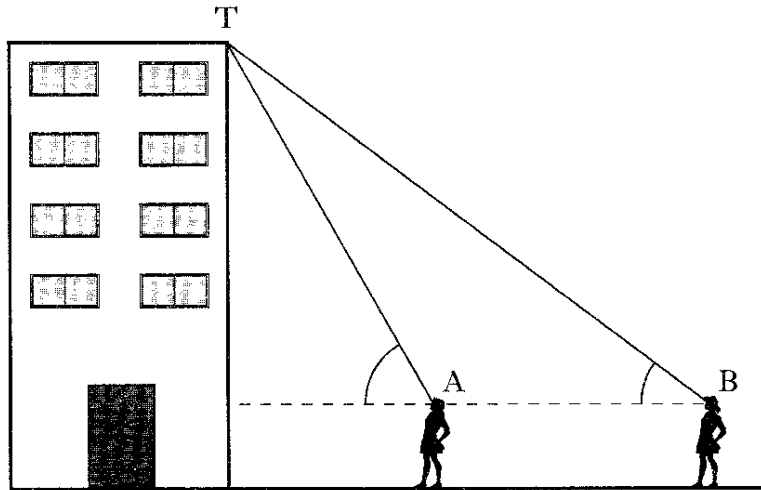

From position B, the angle of elevation to T at the top of the tower is 64° .
 From position A, the angle of elevation to T at the top of the tower is 69° .
 The distance AB is 4.8 metres and the height of the student to eye level is 1.5 metres.

Find the height of the tower.

16. (a) Remove the brackets and simplify

$$b^{\frac{1}{2}}(b^{\frac{1}{2}} + b^{-\frac{1}{2}}).$$

(b) $f(x) = \frac{3}{\sqrt{x}}$

Find the **exact** value of $f(2)$.

Give your answer **as a fraction** with a rational denominator.

(c) $Q = p^2 + 3T$

Change the subject of the formula to T .

KU	RA
	6
	3
	2
	2

17. A sequence of numbers is

1, 5, 12, 22,

Numbers from this sequence can be illustrated in the following way using dots.

First Number
(N = 1)



Second Number
(N = 2)

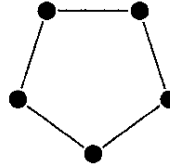

Third Number
(N = 3)

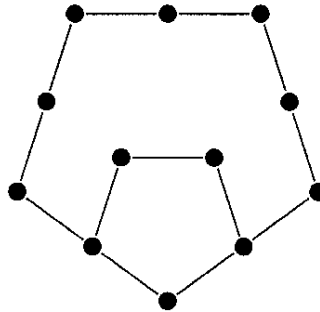

Fourth Number
(N = 4)

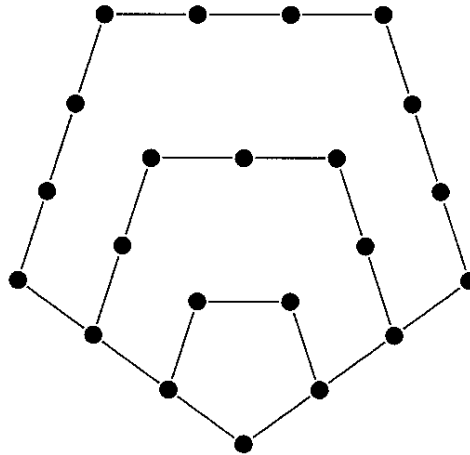

(a) What is the fifth number in this sequence?

Illustrate this in a sketch.

(b) The number of dots, D , needed to illustrate the N th number in this sequence is given by the formula

$$D = aN^2 - bN.$$

Find the values of a and b .

KU	RA
	2
	4

18. (a) The equation $x^3 + 2x^2 - 5 = 0$ has a root between 1 and 2.
Use iteration to find the value of this root correct to one decimal place.
Show clearly all your working.

- (b) Express as a single fraction in its simplest form

$$\frac{5}{x} - \frac{3}{(x-2)}, \quad x \neq 0 \quad \text{or} \quad x \neq 2.$$

19. A rectangular sheet of plastic 18 cm by 100 cm is used to make a gutter for draining rain water.

The gutter is made by bending the sheet of plastic as shown below in diagram 1.

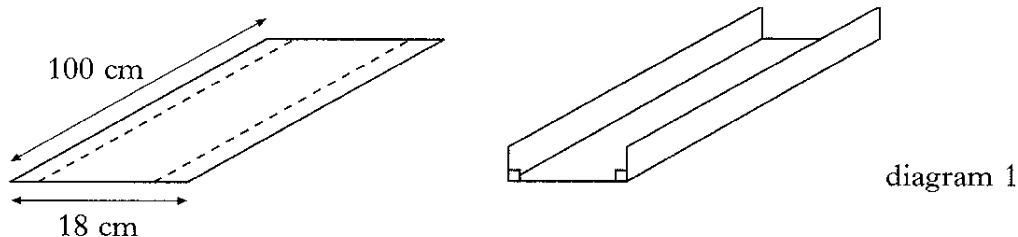

- (a) The depth of the gutter is x centimetres as shown in diagram 2 below.
Write down an expression in x for the width of the gutter.

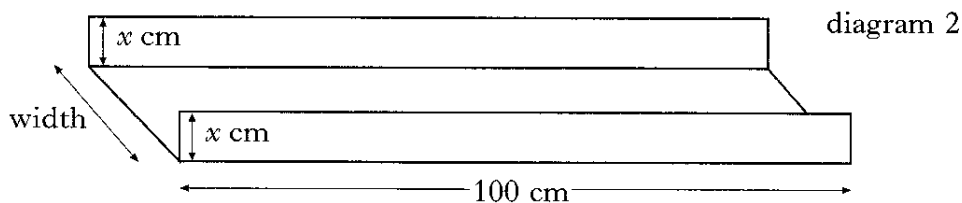

- (b) Show that the volume, V cubic centimetres, of this gutter is given by

$$V = 1800x - 200x^2.$$

- (c) Find the dimensions of the gutter which has the largest volume.

Show clearly all your working.

[END OF QUESTION PAPER]

KU	RA
3	
3	
1	
2	
4	