

FOR OFFICIAL USE

--	--	--	--	--	--

--

Total Marks

X069/101

NATIONAL
QUALIFICATIONS
2008

FRIDAY, 23 MAY
1.00 PM – 2.30 PM

PHYSICS
INTERMEDIATE 1

Fill in these boxes and read what is printed below.

Full name of centre

--

Town

--

Forename(s)

--

Surname

--

Date of birth

Day Month Year

--	--	--	--	--	--	--	--

Scottish candidate number

--	--	--	--	--	--	--	--	--	--

Number of seat

--

Reference may be made to the Physics Data Booklet.

Section A – Questions 1–20 (20 marks)

Instructions for completion of **Section A** are given on page two.

For this section of the examination you must use an **HB pencil**.

Section B (60 marks)

All questions should be attempted.

The questions may be answered in any order but all answers are to be written in the spaces provided in this answer book, **and must be written clearly and legibly in ink**.

Rough work, if any should be necessary, should be written in this book, and then scored through when the fair copy has been written. If further space is required, a supplementary sheet for rough work may be obtained from the invigilator.

Additional space for answers will be found at the end of the book. If further space is required, supplementary sheets may be obtained from the invigilator and should be inserted inside the **front** cover of this booklet.

Before leaving the examination room you must give this book to the invigilator. If you do not, you may lose all the marks for this paper.



SECTION A

- 1 Check that the answer sheet provided is for Physics Intermediate 1 (Section A).
- 2 For this section of the examination you must use an **HB pencil** and, where necessary, an eraser.
- 3 Check that the answer sheet you have been given has **your name, date of birth, SCN** (Scottish Candidate Number) and **Centre Name** printed on it.
Do not change any of these details.
- 4 If any of this information is wrong, tell the Invigilator immediately.
- 5 If this information is correct, **print** your name and seat number in the boxes provided.
- 6 The answer to each question is **either** A, B, C, D or E. Decide what your answer is, then, using your pencil, put a horizontal line in the space provided (see sample question below).
- 7 There is **only one correct** answer to each question.
- 8 Any rough working should be done on the question paper or the rough working sheet, **not** on your answer sheet.
- 9 At the end of the exam, put the **answer sheet for Section A inside the front cover of this answer book.**

Sample Question

The energy unit measured by the electricity meter in your home is the

- A kilowatt-hour
- B ampere
- C watt
- D coulomb
- E volt.

The correct answer is **A**—kilowatt-hour. The answer **A** has been clearly marked in **pencil** with a horizontal line (see below).

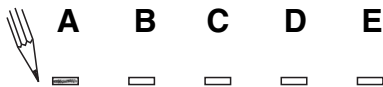

Changing an answer

If you decide to change your answer, carefully erase your first answer and, using your pencil, fill in the answer you want. The answer below has been changed to **E**.

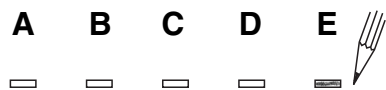

SECTION A

Answer questions 1–20 on the answer sheet.

1. Which of the following colours of light can be mixed to give all the colours seen on a television screen?
- A Red, yellow and blue
 - B Red, green and blue
 - C Blue, magenta and red
 - D Red, orange and yellow
 - E Cyan, green and blue
2. Optical fibres are used to transmit
- A electrical signals
 - B light signals
 - C ultrasound signals
 - D radio signals
 - E sound signals.
3. A fax machine can send information from one location to another. A student makes the following statements about a fax machine.
- I A diagram can be sent by fax.
 - II Documents are faxed at the speed of sound.
 - III Faxes can be sent by telephone.
- Which of these statements is/are correct?
- A I only
 - B I and II only
 - C I and III only
 - D II and III only
 - E I, II and III

[Turn over

4. A telephone handset contains a mouthpiece and an earpiece.
Which row in the table shows the energy changes in the mouthpiece and the earpiece?

	<i>Mouthpiece</i>	<i>Earpiece</i>
A	sound → light	electrical → sound
B	sound → electrical	electrical → sound
C	electrical → sound	sound → electrical
D	electrical → sound	electrical → sound
E	sound → electrical	light → sound

5. A circuit is set up as shown.

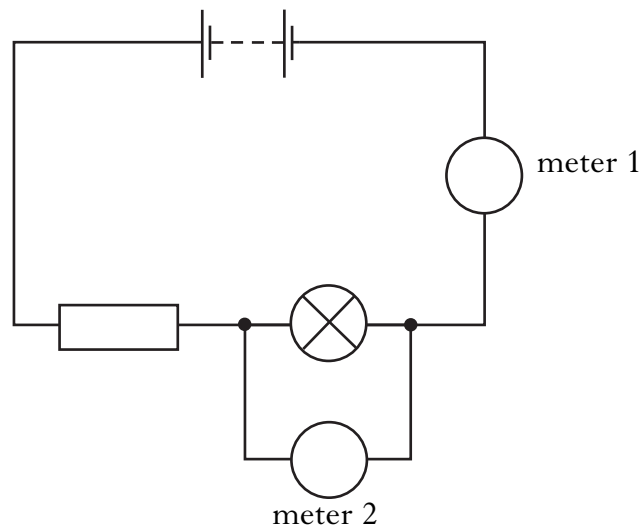

Which row in the table shows the measurements displayed by meter 1 and meter 2?

	<i>Meter 1</i>	<i>Meter 2</i>
A	voltage across lamp	current in lamp
B	voltage across resistor	voltage across lamp
C	current in resistor	voltage across lamp
D	current in lamp	voltage across battery
E	current in resistor	current in lamp

6. A student states that telephone signals can be sent between a transmitter and a receiver in the following ways.

I Using electrical signals in metal wires

II Using light signals in optical fibres

III Using radio signals in air

Which of these statements is/are correct?

A I only

B II only

C I and II only

D I and III only

E I, II and III

7. The diagram shows a mains flex connected correctly to a plug.

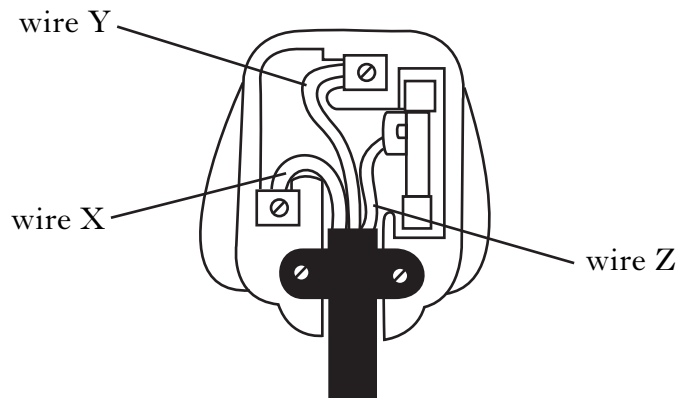

Which row in the table shows the colours of the insulation on wires X, Y and Z?

	<i>Wire X</i>	<i>Wire Y</i>	<i>Wire Z</i>
A	brown	blue	green/yellow
B	green/yellow	brown	blue
C	blue	brown	green/yellow
D	brown	green/yellow	blue
E	blue	green/yellow	brown

[Turn over

8. A circuit is set up as shown.

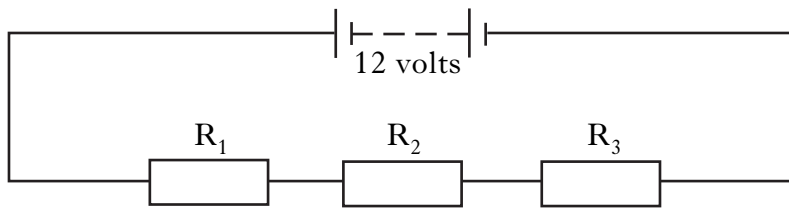

The voltage of the battery is 12 volts. The voltage across resistor R_1 is 5 volts. Which row in the table shows possible voltages across R_2 and R_3 ?

	<i>Voltage across R_2</i>	<i>Voltage across R_3</i>
A	2 volts	3 volts
B	3 volts	4 volts
C	5 volts	5 volts
D	5 volts	12 volts
E	12 volts	12 volts

9. Which of the following statements about gamma radiation is **not** true?

- A Gamma radiation can kill living cells.
- B Gamma radiation can pass through most materials.
- C Gamma radiation is present in our surroundings.
- D Gamma radiation can be used as a tracer.
- E Gamma radiation is visible to the naked eye.

10. The diagram shows rays of light in an eye that has a defect.

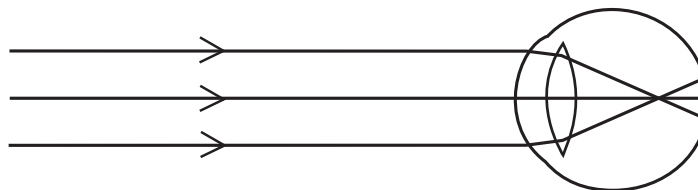

Which shape of lens could be used to correct this defect?



A



B



C



D



E

11. Which of the following graphs shows how the strength of a radioactive source changes with time?

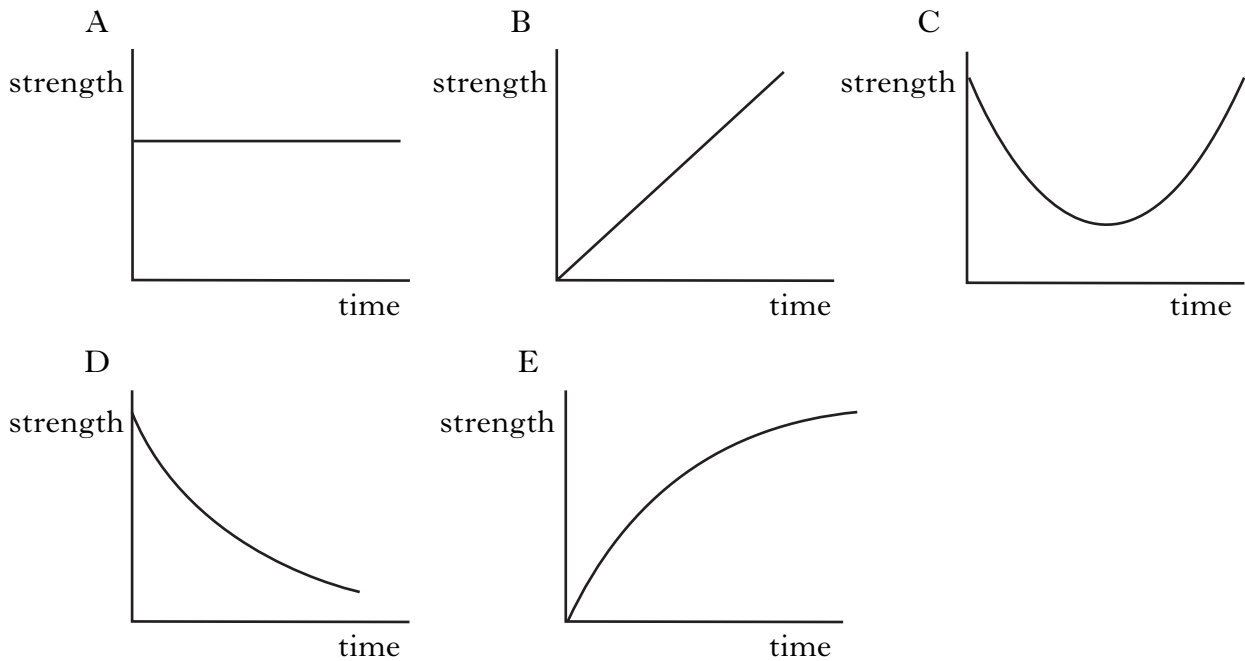

12. During a thunderstorm, the lightning is seen before the thunder is heard.
This is because
- A the eye is more sensitive than the ear
 - B the thunder is produced before the lightning
 - C the lightning is produced before the thunder
 - D light travels faster than sound
 - E sound travels faster than light.
13. Which one of the following frequencies of sound can be heard by the average human?
- A 4 hertz
 - B 12 hertz
 - C 600 hertz
 - D 25 000 hertz
 - E 40 000 hertz
14. Sound level is measured in
- A amperes
 - B decibels
 - C hertz
 - D ohms
 - E volts.

15. A block is at rest on a smooth surface.
A force of 20 newtons is now applied to the block as shown.



The block will

- A remain at rest
 - B move to the right at a constant speed
 - C move to the left at a constant speed
 - D move to the right with an increasing speed
 - E move to the left with an increasing speed.
16. A student throws a ball at 3 metres per second in the direction shown.

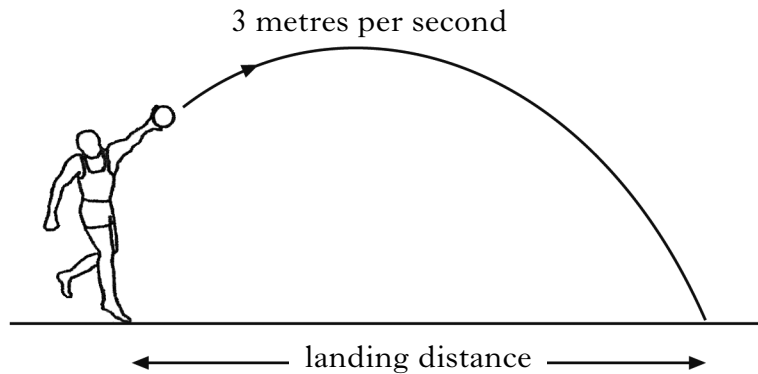

The landing distance would be increased by

- A increasing the mass of the ball
- B increasing the speed of the throw of the ball
- C increasing the weight of the ball
- D decreasing the force of the throw
- E decreasing the speed of the throw of the ball.

17. A car accelerates to overtake a lorry.

Acceleration is the

- A change in speed each second
- B change in time each second
- C change in distance each second
- D change in force each second
- E change in mass each second.

18. A trolley is released from position P on a slope as shown.

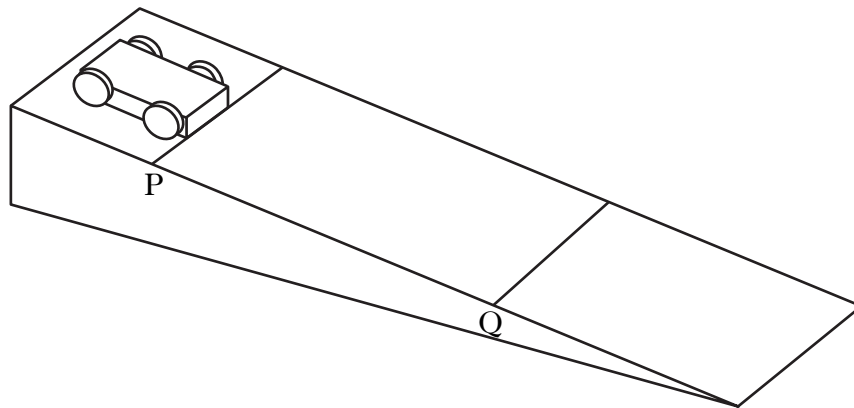

The length of the trolley is 0.2 metres.

To calculate the instantaneous speed of the trolley at Q, we also need to know

- A the distance from position P to position Q
- B the time taken by the trolley to move from position P to position Q
- C the speed of the trolley at position P
- D the time taken for the trolley to pass position P
- E the time taken for the trolley to pass position Q.

19. A student designs an electronic system to sound an alarm when an engine gets too hot.

Which row in the table shows suitable input and output devices for this system?

	<i>Input device</i>	<i>Output device</i>
A	LDR	thermistor
B	buzzer	thermistor
C	thermistor	LDR
D	thermistor	buzzer
E	LDR	buzzer

20. The digital signal shown below is applied to the input of a NOT gate.



digital signal

The output signal from the NOT gate is



Candidates are reminded that the answer sheet for Section A MUST be placed INSIDE the front cover of this answer book.

Marks

SECTION B

Answer questions 21–30 in the spaces provided.

21. Some mobile phones have GPS (Global Positioning System).



This means that you can find out where you are if you are lost.

(a) Complete the sentences below using some of these words.

- | | | | |
|--------------|------------|---------------|----------------------|
| light | 200 | radio | electrical |
| sound | 300 | energy | geostationary |

The GPS phone uses waves to receive signals from satellites in space. These waves transfer .

The waves travel at a speed of million metres per second. A satellite that stays above the same point on the Earth's surface is called a satellite.

2

(b) It takes 0.12 seconds for a signal to travel from a satellite 36 million metres above the Earth to the GPS phone.

(i) What time does a signal take to travel from a different satellite 18 million metres above the Earth?

1

(ii) Explain your answer.

1

22. (a) A block diagram of a radio receiver is shown.

Marks

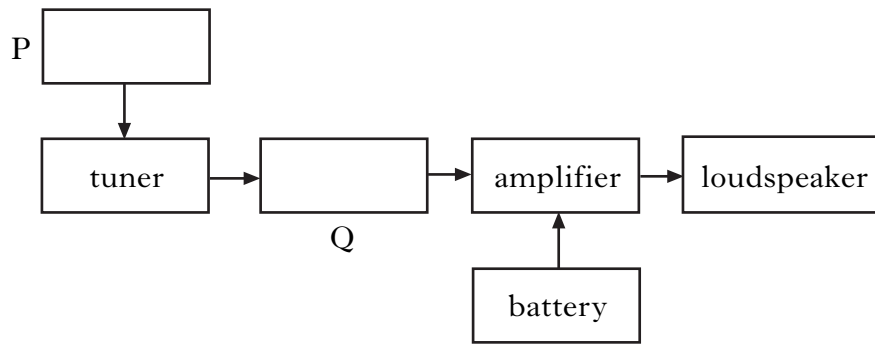

(i) Complete the diagram by labelling blocks P and Q.

2

(ii) What is the function of the tuner?

1

(b) Oscilloscopes are connected across the input and output of the amplifier. The settings on each oscilloscope are the same.

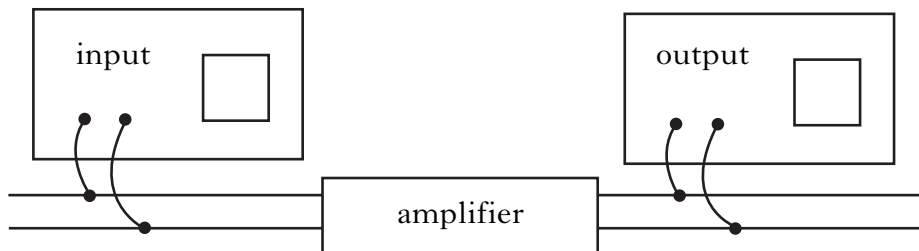

(i) The diagram below shows the input signal.

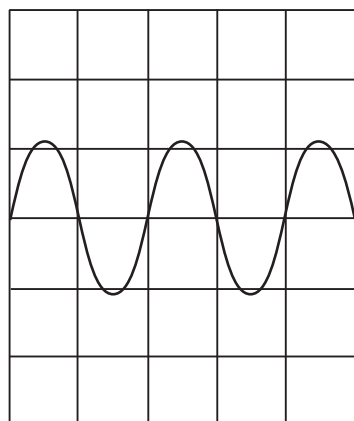

input

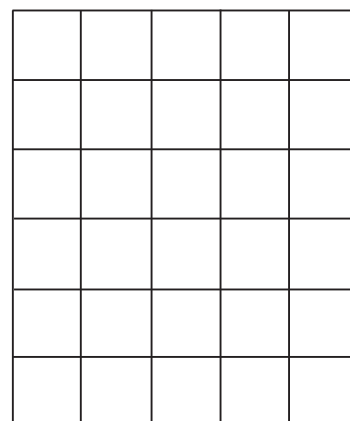

output

On the output diagram draw, the output signal from the amplifier.

2

Marks

22. (b) (continued)

- (ii) The frequency of the input signal is now increased.

What change will there be in the output signal shown on the oscilloscope?

1

- (c) The diagram below shows an amplifier connected to a signal generator and a loudspeaker. Voltmeters measure the input and output voltages of the amplifier.

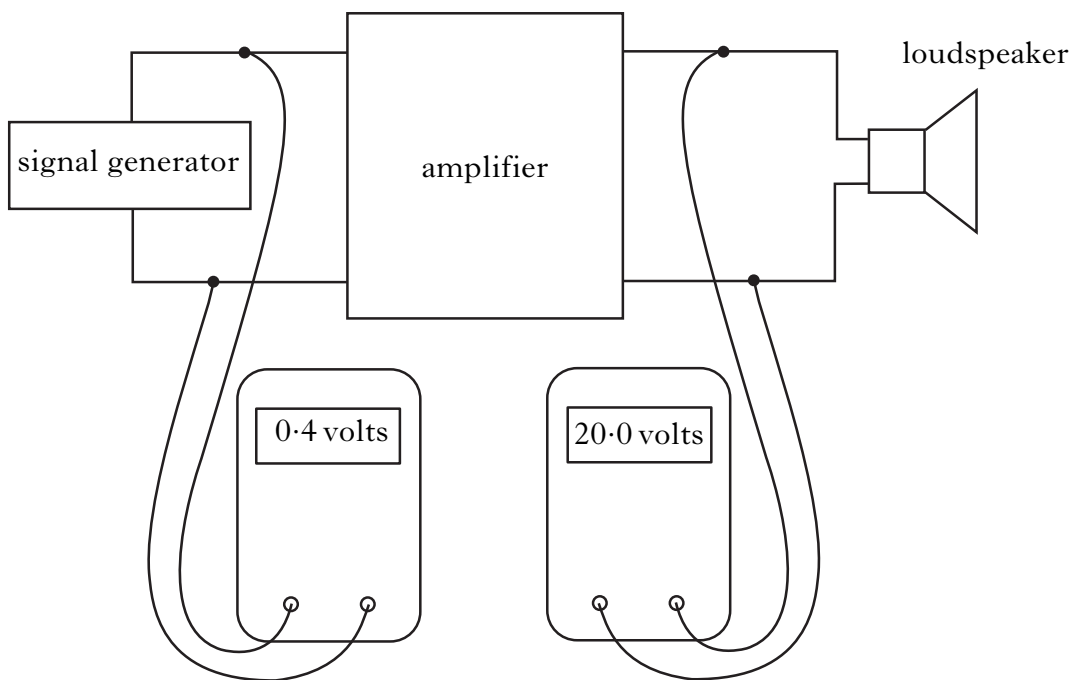

Using information from the diagram, calculate the voltage gain of the amplifier.

2

[Turn over

Marks

23. (a) A technician for a lamp company is investigating the properties of a lamp at different voltages.

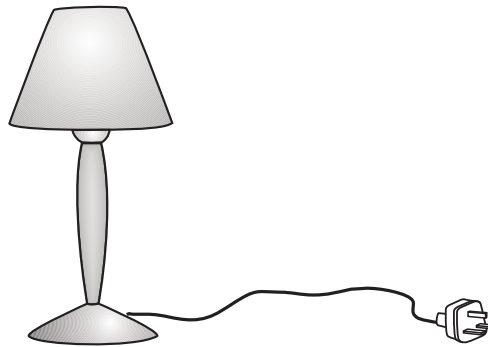

For different voltages the technician measures the current in the lamp. The graph of her results is shown below.

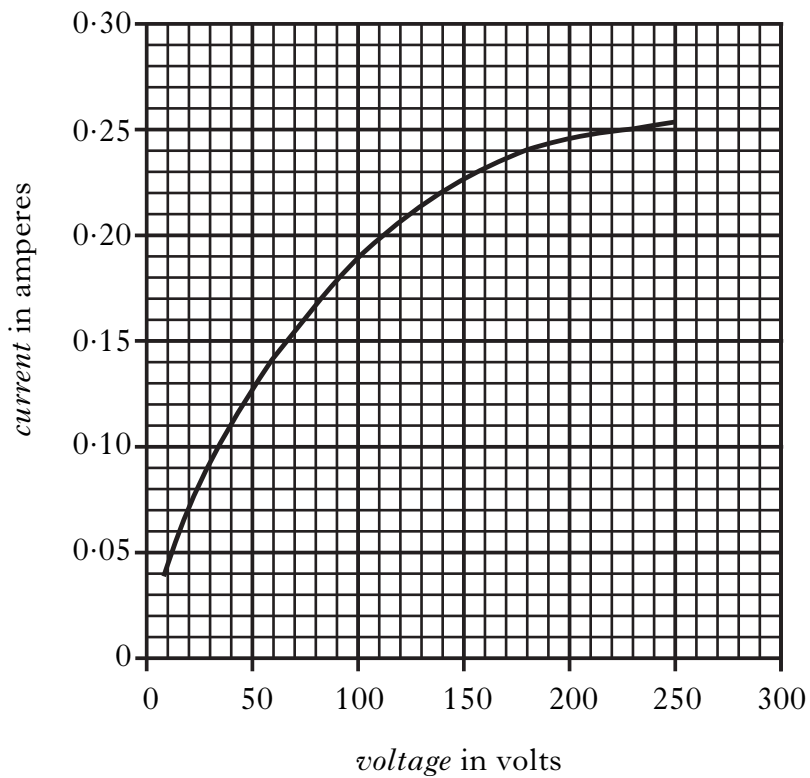

- (i) What is the value of mains voltage?

1

Marks

23. (a) (continued)

- (ii) What is the current in the lamp when it is being operated at mains voltage?

1

- (iii) Calculate the resistance of the bulb at mains voltage.

2

- (b) The bulb is now operated at a lower voltage than mains voltage.

- (i) Will the resistance of the bulb be **bigger**, **smaller** or **the same as** your answer in (a)(iii)?

1

- (ii) Explain your answer.

1

[Turn over

Marks

24. The following is part of a crossword.

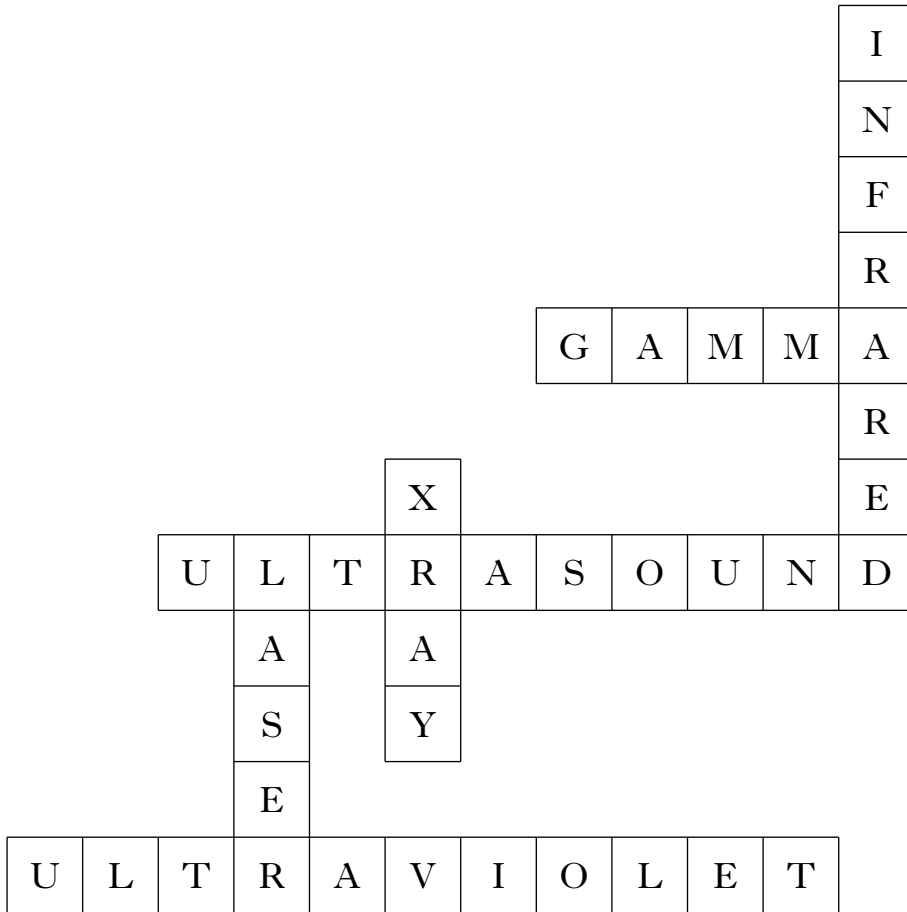

(a) Select **three** answers from the crossword to complete the table below.

<i>Medical use</i>	<i>Answer from crossword</i>
Scanning an unborn baby	
Detecting broken bones	
Treating vitamin deficiency	

3

(b) What is another name for infrared?

1

Marks

25. (a) Laser light reflects in the same way as light from a filament lamp.
Complete the diagram to show the normal and the reflected beam.

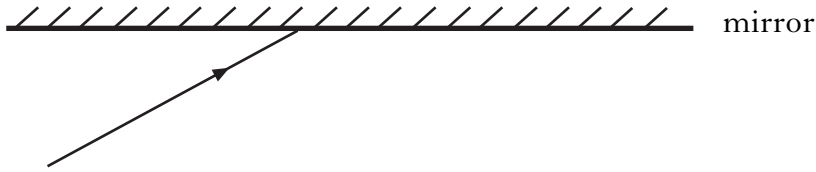

2

- (b) Lasers can be used to cut sheets of metal.
A lens is used to focus the laser light onto the metal.
Complete the following diagram showing the correct shape of lens and the effect it has on the beam of light.

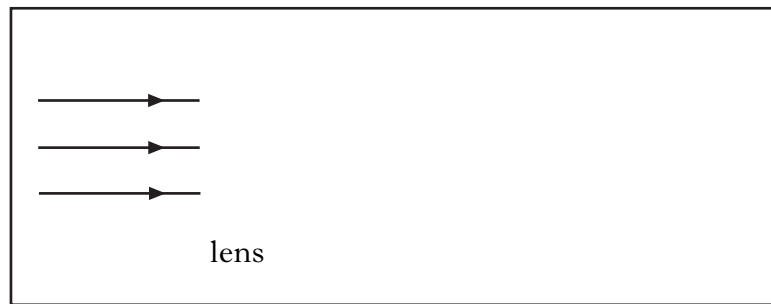

2

- (c) Some students use a low power laser to try to show the security markings on bank notes. They are not successful.
What type of radiation should they use?

1

[Turn over

Marks

26. (a) A student is learning to play the panpipes. He blows across the pipes and each one produces a different note.

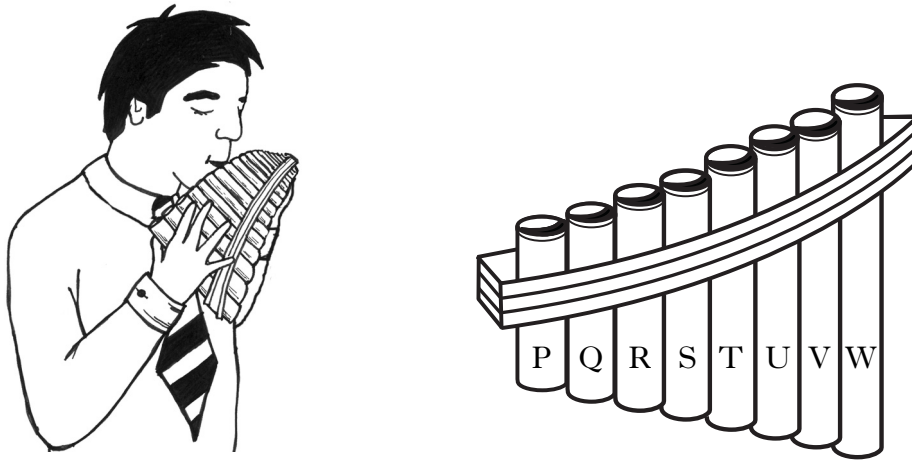

- (i) What must the air in the pipes be doing to produce the notes?

1

- (ii) Which pipe will produce the highest frequency note when the student blows across it?

1

- (iii) The notes from pipes Q and W are an octave apart.
Pipe W produces sound of frequency 256 hertz.
What is the frequency of the sound from pipe Q?

1

Marks

26. (continued)

- (b) The student investigates the speed of sound in different gases. He designs an experiment as shown below. A short note is produced by the loudspeaker and the sound travels through the tank from one microphone to the other.

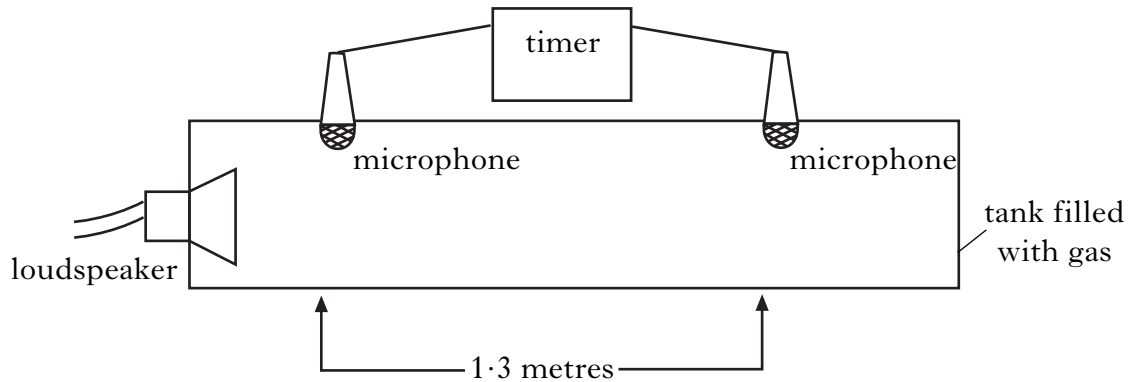

- (i) The tank is filled with carbon dioxide. The sound travels a distance of 1.3 metres from the first microphone to the second microphone. The timer records a time of 0.005 seconds. Calculate the speed of sound in carbon dioxide.

2

- (ii) The tank is now filled with a different gas. The time recorded on the timer is less than 0.005 seconds.
- (A) Is the speed of sound in this gas **less than, equal to or more than** the speed of sound in carbon dioxide?

1

- (B) Explain your answer.

1

Marks

27. The picture shows a motorcyclist on a motorbike.

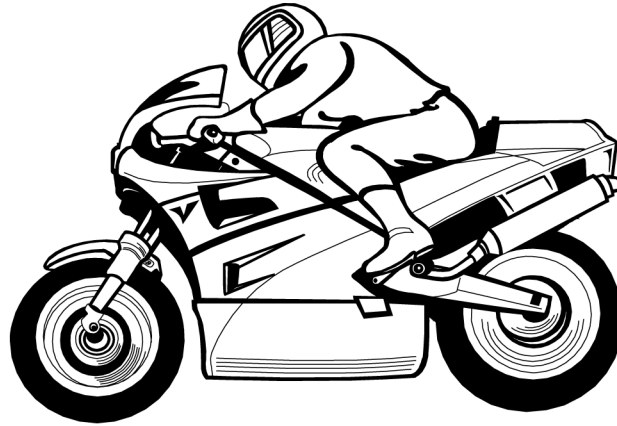

(a) The motorbike goes from 0 to 28 metres per second in 3 seconds.

- (i) The motorbike covers a distance of 42 metres during this time.
Calculate the average speed.

2

- (ii) The motorcyclist is comparing the performance of his motorbike with another bike. The performances of the two bikes are shown in the table.

	<i>Shortest time for 0–28 metres per second in seconds</i>	<i>Engine power in brake horse power</i>	<i>Mass in kilograms</i>
Bike 1	3	150	181
Bike 2		121	181

Complete the table to show a possible time for Bike 2.

1

Marks

27. (continued)

(b) The headlamp of one of the motorbikes uses a 12 volt, 60 watt bulb.

- (i) Calculate the current drawn from the battery when the headlamp is operating.

2

- (ii) Circle the most suitable size of fuse required to protect the bulb circuit.

3 amperes 10 amperes 13 amperes

1

- (iii) Draw a circuit diagram showing how the bulb, battery, ignition switch and fuse are connected.

2

[Turn over

Marks

28. At the end of a week of skiing lessons, students are given a chance to try a short downhill course.

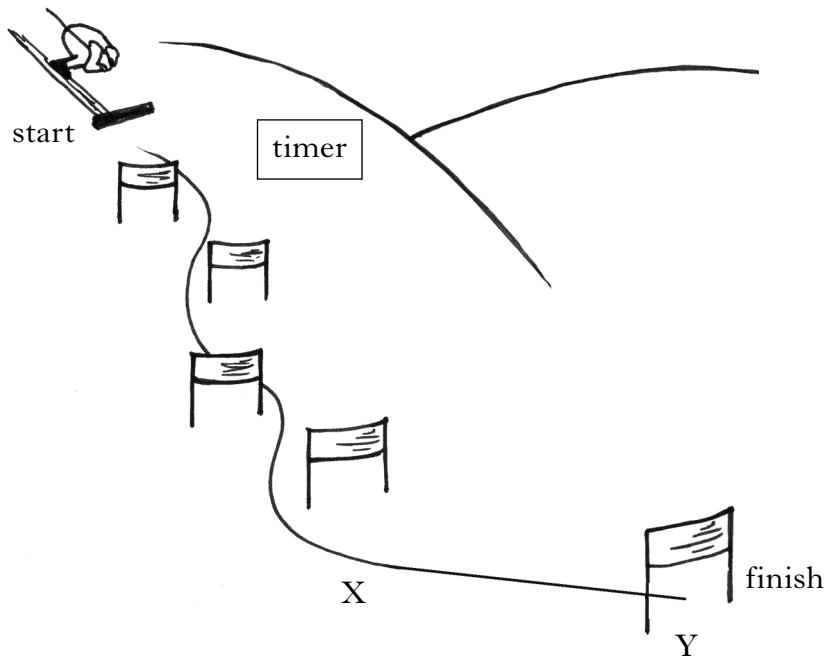

(a) The students want to calculate the average speed of a skier down the course. An electronic timer is used to measure the time between the start and finish lines.

(i) What electronic device could be used to stop the timer at the finish line?

1

(ii) What other measurement is needed to calculate the average speed?

1

(iii) How would these measurements be used to calculate the average speed?

1

Marks

28. (continued)

- (b) (i) The mass of the skier is 60 kilograms.
Calculate the weight of the skier.

2

- (ii) Between points X and Y the forces on the skier are balanced.
What happens to the speed of the skier between points X and Y?

1

[Turn over

Marks

29. (a) An electronic system consists of three parts.
Complete the block diagram below.



1

- (b) Some electronic devices are listed below.

microphone

motor

switch

loudspeaker

lamp

LED

- (i) Complete the table below by putting each device in the correct column.

<i>Input device</i>	<i>Output device</i>

3

- (ii) What is the energy change in an LED?

1

Marks

29. (continued)

- (c) The resistance of an LDR is measured as the light level increases.
The results are shown on a graph.

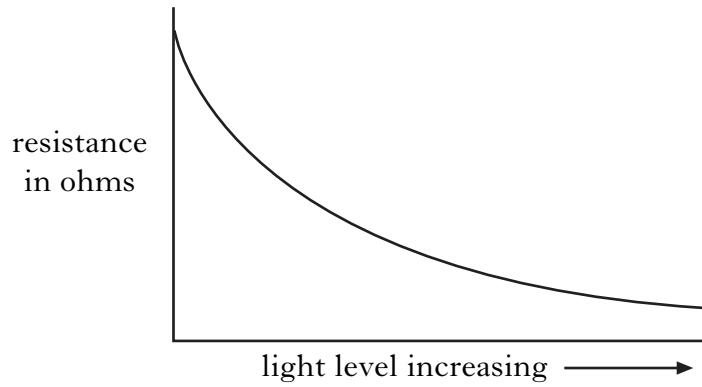

- (i) Looking at the graph, state what happens to the resistance of the LDR as the light level increases.

1

- (ii) Name the meter used to measure resistance.

1

[Turn over

Marks

30. A car alarm system has two sensors.
One sensor activates if someone smashes a window.
The second sensor activates if someone tries to move the car.
Each sensor gives a high output when activated.

(a) The two sensors are connected to a logic gate as shown.

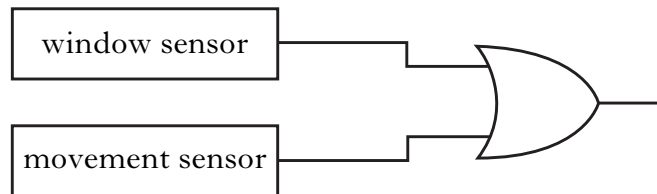

Complete the table to show the output from the logic gate.

<i>Logic level of window sensor</i>	<i>Logic level of movement sensor</i>	<i>Output logic level of gate</i>
0	0	
0	1	
1	0	
1	1	

1

Marks

30. (continued)

(b) If the owner wants to drive the car, the alarm must be switched off.

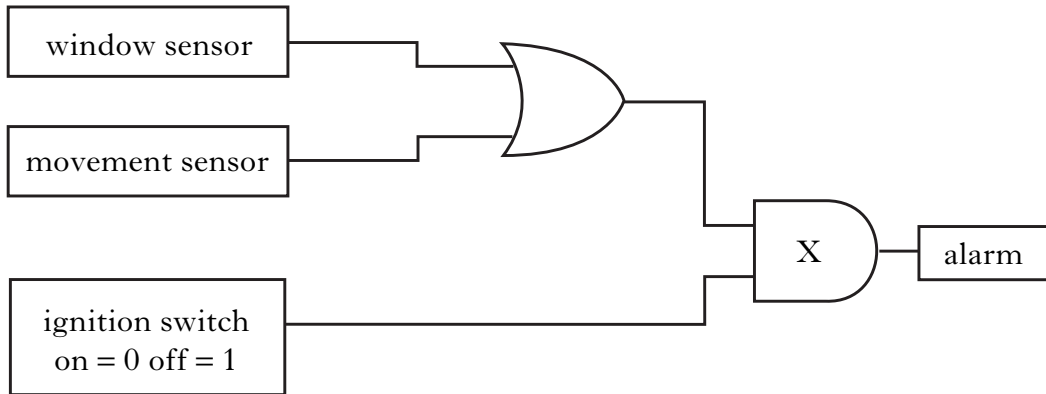

(i) Name logic gate X.

1

(ii) Is the output from the ignition switch **high** or **low** when the switch is on?

1

(iii) Explain why the alarm will not sound if the car is moved when the ignition switch is on.

2

[END OF QUESTION PAPER]

Marks

YOU MAY USE THE SPACE ON THIS PAGE TO REWRITE ANY ANSWER YOU HAVE DECIDED TO CHANGE IN THE MAIN PART OF THE ANSWER BOOKLET. TAKE CARE TO WRITE IN CAREFULLY THE APPROPRIATE QUESTION NUMBER.

ACKNOWLEDGEMENTS

Section B Question 21—Picture of a Nokia mobile phone. Reproduced by kind permission of Nokia Head Office