

FOR OFFICIAL USE

--	--	--	--	--	--

Total  
Marks

--

**X069/101**

NATIONAL  
QUALIFICATIONS  
2010

FRIDAY, 28 MAY  
1.00 PM – 2.30 PM

PHYSICS  
INTERMEDIATE 1

Fill in these boxes and read what is printed below.

Full name of centre

--

Town

--

Forename

--

Surname

--

Date of birth

Day    Month    Year

--	--	--	--	--	--

Scottish candidate number

--	--	--	--	--	--	--	--	--	--

Number of seat

--

Reference may be made to the Physics Data Booklet.

**Section A – Questions 1–20 (20 marks)**

Instructions for completion of **Section A** are given on page two.

For this section of the examination you must use an **HB pencil**.

**Section B (60 marks)**

All questions should be attempted.

The questions may be answered in any order but all answers are to be written in the spaces provided in this answer book, **and must be written clearly and legibly in ink**.

Rough work, if any should be necessary, should be written in this book, and then scored through when the fair copy has been written. If further space is required, a supplementary sheet for rough work may be obtained from the Invigilator.

Additional space for answers will be found at the end of the book. If further space is required, supplementary sheets may be obtained from the Invigilator and should be inserted inside the **front** cover of this booklet.

Before leaving the examination room you must give this book to the Invigilator. If you do not, you may lose all the marks for this paper.



## SECTION A

- 1 Check that the answer sheet provided is for Physics Intermediate 1 (Section A).
- 2 For this section of the examination you must use an **HB pencil** and, where necessary, an eraser.
- 3 Check that the answer sheet you have been given has **your name, date of birth, SCN** (Scottish Candidate Number) and **Centre Name** printed on it.  
Do not change any of these details.
- 4 If any of this information is wrong, tell the Invigilator immediately.
- 5 If this information is correct, **print** your name and seat number in the boxes provided.
- 6 The answer to each question is **either** A, B, C, D or E. Decide what your answer is, then, using your pencil, put a horizontal line in the space provided (see sample question below).
- 7 There is **only one correct** answer to each question.
- 8 Any rough working should be done on the question paper or the rough working sheet, **not** on your answer sheet.
- 9 At the end of the exam, put the **answer sheet for Section A inside the front cover of this answer book.**

### Sample Question

The energy unit measured by the electricity meter in your home is the

- A kilowatt-hour
- B ampere
- C watt
- D coulomb
- E volt.

The correct answer is **A**—kilowatt-hour. The answer **A** has been clearly marked in **pencil** with a horizontal line (see below).



### Changing an answer

If you decide to change your answer, carefully erase your first answer and, using your pencil, fill in the answer you want. The answer below has been changed to **E**.

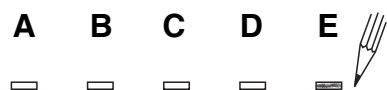

**SECTION A**

**Answer questions 1–20 on the answer sheet.**

1. The block diagram shows the parts of a radio receiver.

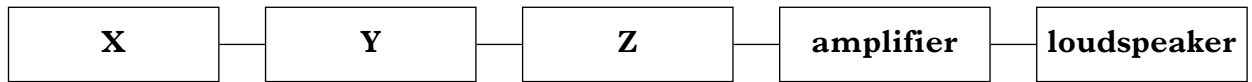

Which row in the table correctly names **X**, **Y** and **Z**?

	<b>X</b>	<b>Y</b>	<b>Z</b>
A	aerial	decoder	tuner
B	decoder	tuner	aerial
C	tuner	aerial	decoder
D	aerial	tuner	decoder
E	tuner	decoder	aerial

2. A student makes the following statements about radio communication.

- I Radio waves travel faster than sound waves.
- II The useful energy change in the loudspeaker of a radio receiver is electrical energy to sound.
- III The aerial of a radio receiver picks up only one radio signal.

Which of the statements is/are correct?

- A I only
- B II only
- C III only
- D I and II only
- E II and III only

**[Turn over**

3. The diagram shows the waves produced by a source in two seconds.

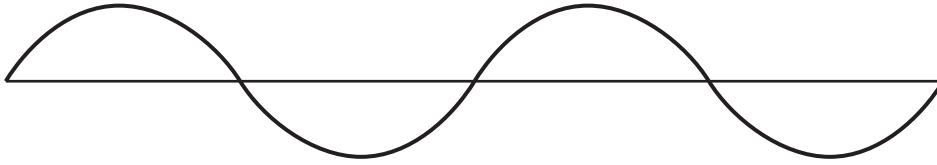

The frequency of the waves is

- A 0.5 hertz
- B 1 hertz
- C 2 hertz
- D 4 hertz
- E 8 hertz.

4. A student is wiring a plug.

Which row in the table shows the colour of the insulation for the live, neutral and earth wires?

	<i>Live wire</i>	<i>Neutral wire</i>	<i>Earth wire</i>
A	blue	brown	green/yellow
B	green/yellow	blue	brown
C	brown	blue	green/yellow
D	brown	green/yellow	blue
E	green/yellow	brown	blue

5. Which of the following is the symbol for a fuse?

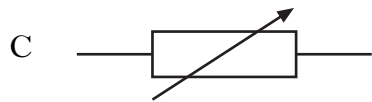
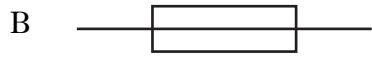
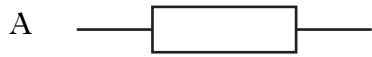

6. A student tests a resistor to find if it has an open circuit.

Which circuit should the student use?

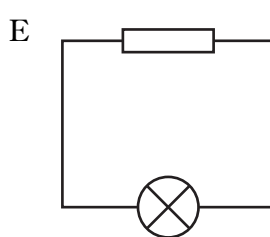
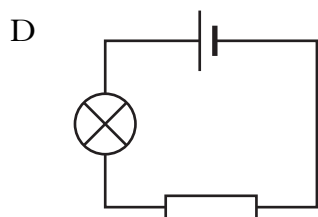
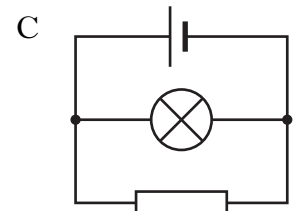
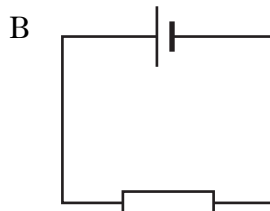
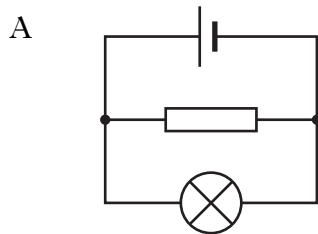

[Turn over

7. A circuit is set up as shown.

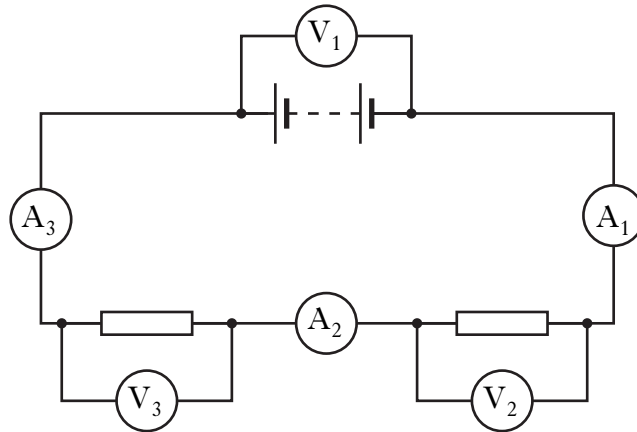

A student makes the following statements about the circuit.

- I In the circuit the two resistors are connected in series.
- II The readings on the ammeters  $A_1$ ,  $A_2$  and  $A_3$  are the same.
- III The readings on the voltmeters  $V_1$ ,  $V_2$  and  $V_3$  are the same.

Which of the statements is/are correct?

- A I only
  - B II only
  - C I and II only
  - D I and III only
  - E I, II and III
8. X-rays are used in medicine to show broken bones.  
X-rays can be detected using
- A an optical fibre
  - B photographic film
  - C a thermistor
  - D an LED
  - E an eye.
9. A T-shirt fluoresces at a disco because the chemicals in the T-shirt absorb ultraviolet radiation.  
The chemicals are giving out
- A light
  - B X-rays
  - C ultrasound
  - D microwaves
  - E infrared radiation.

10. Which of the following materials would be best for making a container to store a source of gamma radiation?

All the materials are the same thickness.

- A Aluminium
- B Lead
- C Paper
- D Plastic
- E Wood

11. A ray of light is reflected from a mirror.

Which diagram shows the path of this ray of light before and after reflection?

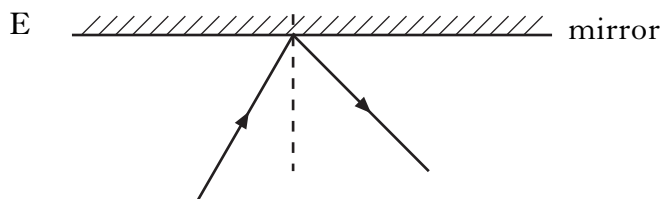
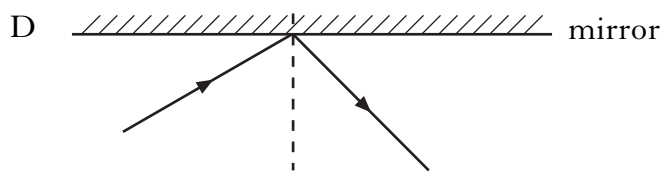
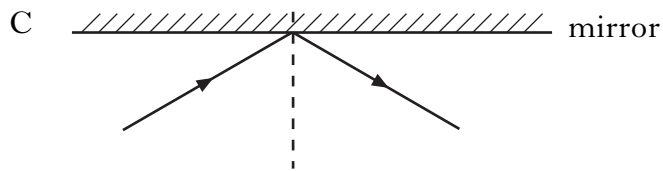
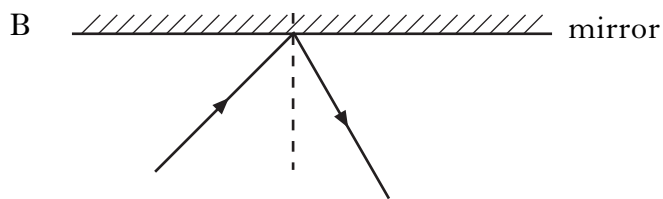
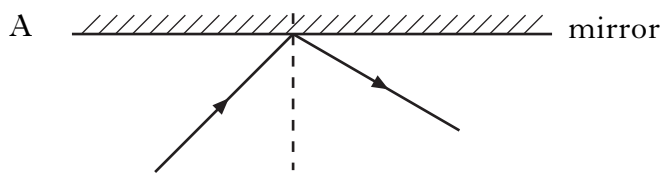

[Turn over

12. Which of the following examples **cannot** be used to show that the speed of sound in air is less than the speed of light in air?
- A Watching a low flying jet plane
  - B Watching a fireworks display
  - C Watching thunder and lightning
  - D Watching a TV programme in a room
  - E Watching a golfer hit a golf ball

13. Which of the following frequency ranges is only ultrasound?
- A Frequencies from 1 hertz to 250 hertz
  - B Frequencies from 20 hertz to 20 000 hertz
  - C Frequencies from 30 hertz to 30 000 hertz
  - D Frequencies from 2000 hertz to 200 000 hertz
  - E Frequencies from 25 000 hertz to 30 000 hertz

14. The diagrams show forces acting on moving objects.  
Which object is moving at constant speed?

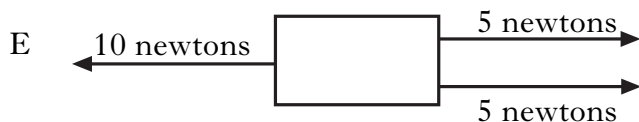
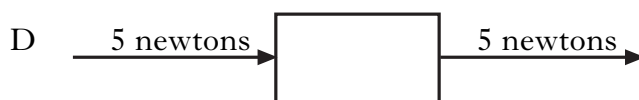
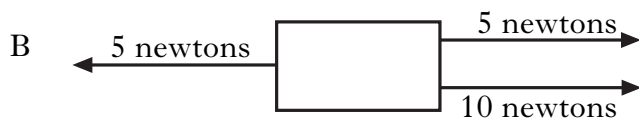



15. The acceleration of a moving car is
- A the distance covered by the car in one second
  - B the change in speed of the car in one second
  - C the average speed of the car in one second
  - D the maximum speed of the car in one second
  - E the force acting on the car in one second.
16. The Earth's pull on an object is called
- A friction
  - B mass
  - C power
  - D acceleration
  - E weight.
17. Which of the following is a suitable **input** device for a doorbell circuit?
- A Switch
  - B LED
  - C Motor
  - D Buzzer
  - E Loudspeaker
18. The following statements are made about an OR gate.
- I The output is logic 0 when both inputs are logic 0.
  - II The output is logic 0 when only one of the inputs is logic 1.
  - III The output is logic 1 when both inputs are logic 1.
- Which of the statements is/are correct?
- A I only
  - B II only
  - C III only
  - D I and II only
  - E I and III only

**[Turn over**

19. Two output devices which produce the same energy change are
- A a buzzer and a loudspeaker
  - B a loudspeaker and an electric motor
  - C an LED and a loudspeaker
  - D a buzzer and a lamp
  - E an LED and an electric motor.

20. An electronic system is shown.

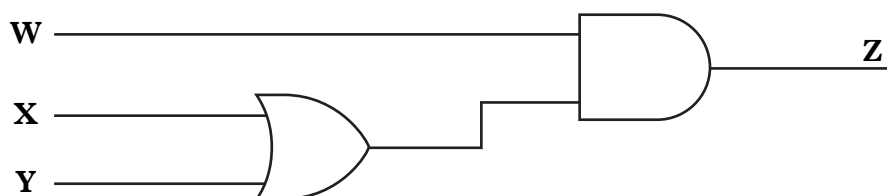

The logic state at **Z** is 1.

Which row in the table shows possible logic states at **W**, **X** and **Y**?

	<i>Logic state at W</i>	<i>Logic state at X</i>	<i>Logic state at Y</i>
A	0	1	0
B	0	1	1
C	0	0	1
D	1	1	0
E	1	0	0

**Candidates are reminded that the answer sheet for Section A MUST be placed INSIDE the front cover of this answer book.**

**SECTION B**

Marks

**Answer questions 21–31 in the spaces provided.**

21. A satellite dish is used to detect TV signals.

(a) Complete the sentences below using some of these words.

- lower**                      **higher**                      **340**                      **300 million**  
**200 million**              **stronger**                  **geostationary**              **weaker**

TV signals have a  frequency than radio signals.

TV signals travel at a speed of  metres per second.

A satellite dish is curved to make the received signal .

A satellite that stays above the same point on the Earth's surface is called a  satellite.

2

(b) Complete the diagram to show the effect the satellite dish has on the TV signals received.

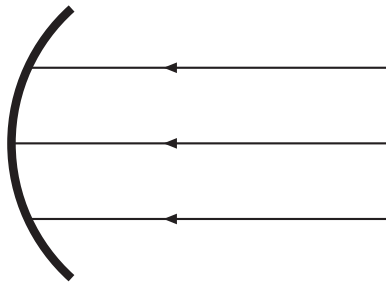

2

(c) (i) If the curved dish is made larger, does the received signal strength **increase, decrease** or **stay the same**?

1

(ii) Explain your answer.

1

Marks

22. Hand-held TV sets are popular with people on the move.



(a) What **two** colours are needed to create the colour magenta on the TV screen?

1

(b) A TV station can be identified by name or by channel number. How else can a TV station be identified?

1

Marks

## 22. (continued)

- (c) An amplifier in the hand-held TV is used to amplify the signal.  
A technician tests the voltages across the amplifier.

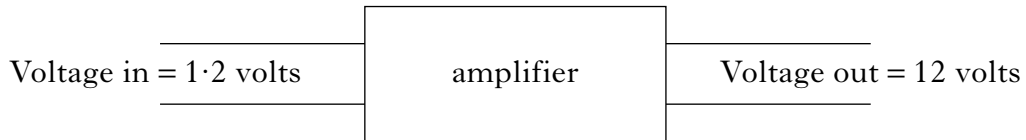

- (i) Calculate the voltage gain of the amplifier.

2

- (ii) One station transmits a signal of frequency 200 million hertz.  
When the signal is amplified does this frequency **increase**,  
**decrease** or **stay the same**?

1

[Turn over]

Marks

23. A student sets up the following circuit.

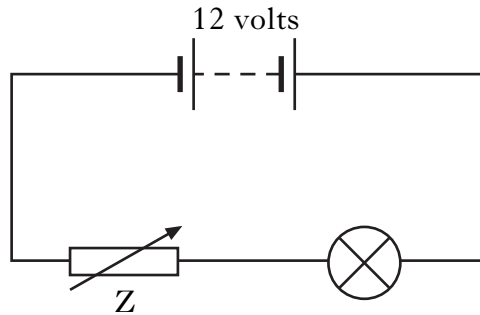

(a) What is component Z?

1

(b) The student measures the voltage across the lamp with a voltmeter.

(i) Draw the symbol for a voltmeter.

1

(ii) Add your symbol to the circuit diagram above to show the voltmeter measuring the voltage across the lamp.

1

(iii) The voltage across the lamp is 7 volts.

What is the voltage across component Z?

1

Marks

## 23. (continued)

- (c) The student rearranges the circuit so that the components are connected as shown below.

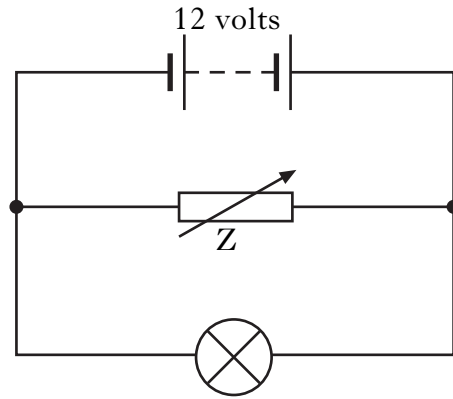

The resistance of component  $Z$  is now reduced.

- (i) State whether the total current in the circuit **increases**, **decreases** or **stays the same**.

1

- (ii) Explain your answer.

1

**[Turn over**

Marks

24. (a) Ceramic hair straighteners rated at 46 watts are connected to the mains voltage of 230 volts.

When the straighteners are switched on, an LED lights up on the handle.



- (i) Calculate the current in the straighteners when they are switched on.

2

- (ii) Calculate the resistance of the straighteners.

2

- (b) The straighteners have a “sleep mode”. This means that after 30 minutes the straighteners no longer give off any heat energy but the LED remains on.

- (i) Give **one** advantage of having a “sleep mode”.

1

- (ii) State the useful energy change of the LED.

1



Marks

25. A student downloads a ringtone onto a mobile phone. The ringtone has a single frequency of 17 000 hertz.

The table below shows the highest frequency that members of the student's household can hear.

<i>Member of household</i>	<i>Highest frequency heard in hertz</i>
Student	20 000
Mum	18 000
Dad	16 000
Gran	15 000
Dog	25 000

- (a) (i) What is the meaning of frequency?

1

- (ii) Which members of the household would hear the ringtone?

2

- (b) The student uses the infrared port on the mobile phone to send a picture to a friend's mobile phone.

- (i) What is another name for infrared radiation?

1

- (ii) Give another example of a use for infrared radiation.

1

Marks

26. A student has an eye defect and needs to wear glasses to correct her vision. The diagram shows what happens to the rays of light entering her eye when she is not wearing glasses.

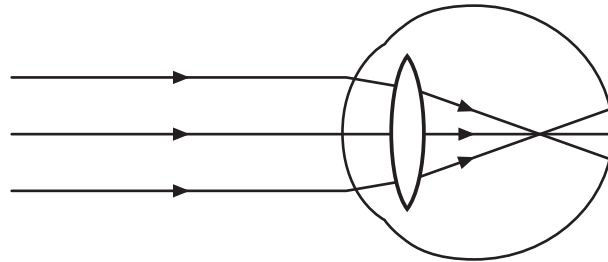

- (a) (i) Name the eye defect.

1

- (ii) Complete the diagram below to show:

the type of lens used in her glasses

**and**

the path of the three rays of light when she is wearing her glasses.

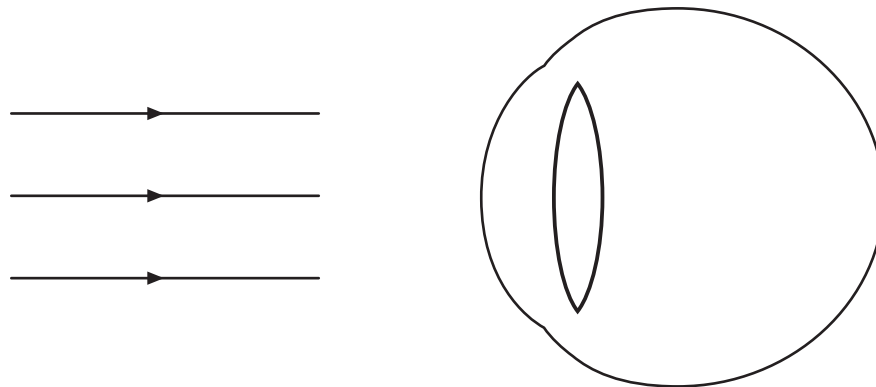

2

Marks

26. (continued)

(b) The student might consider laser eye surgery to correct her vision.

(i) Give **one** way that laser light is different from white light.

--

1

(ii) Lasers can also be used in keyhole surgery using an endoscope.

Complete the diagram below to show how the light passes along an optical fibre.

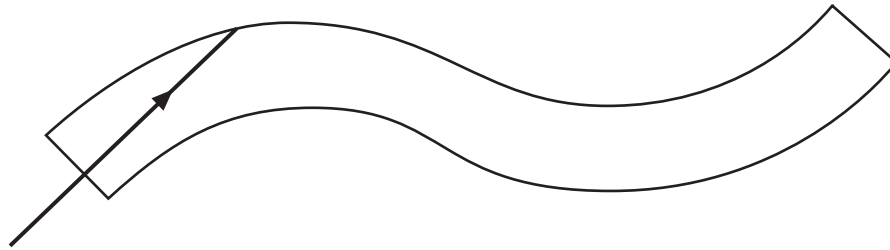

2

[Turn over

Marks

27. (a) The output signal from an electric guitar is connected to an oscilloscope.

The following trace is produced when a note is played.

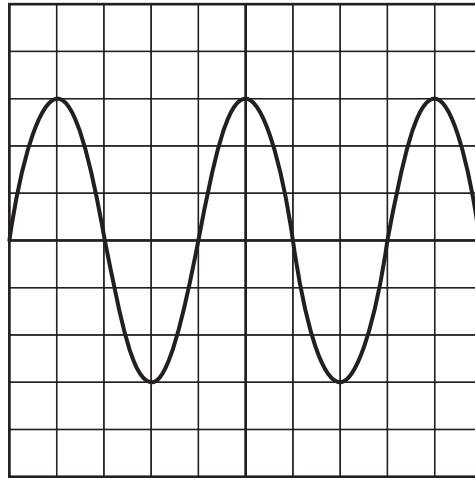

The guitarist plays a different note on the same string.

A new trace is produced on the oscilloscope as shown below.

The settings on the oscilloscope have not been changed.

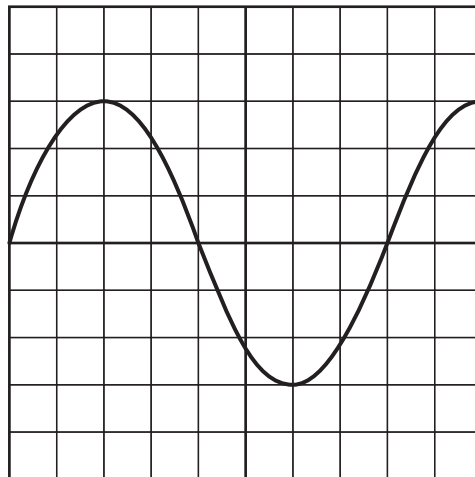

The guitarist could have made **two** changes to the string.

What are the two changes?

Change 1

Change 2

2

Marks

27. (continued)

(b) The guitarist uses a sound level meter to measure the loudness.

(i) The unit of sound level is the  . 1

(ii) Explain why it is important to keep the sound level below the safety limit.

1

(c) The guitarist measures the speed of sound in air.  
He sets up the experiment shown below.

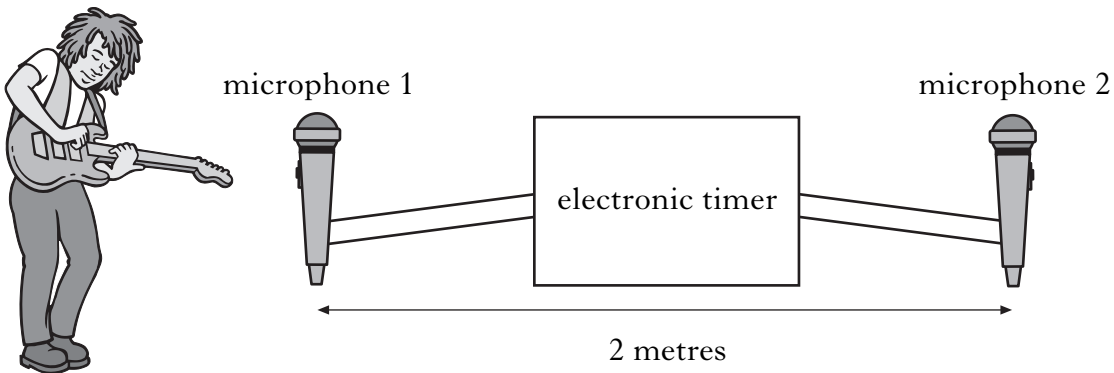

He plays a note on the guitar. The electronic timer measures the time taken for the sound to travel from microphone 1 to microphone 2.

The time recorded on the electronic timer is 0.00625 seconds.

Calculate the speed of sound in air.

2

Marks

28. A pole vaulter wants to find out which material is best for making a landing surface. Four materials are tested in a lab.

A dummy body is dropped onto each surface in turn.

The maximum force exerted on the dummy by each surface is measured.

The dummy is dropped from the same height each time.

The graph shows the maximum force exerted by the different surfaces.

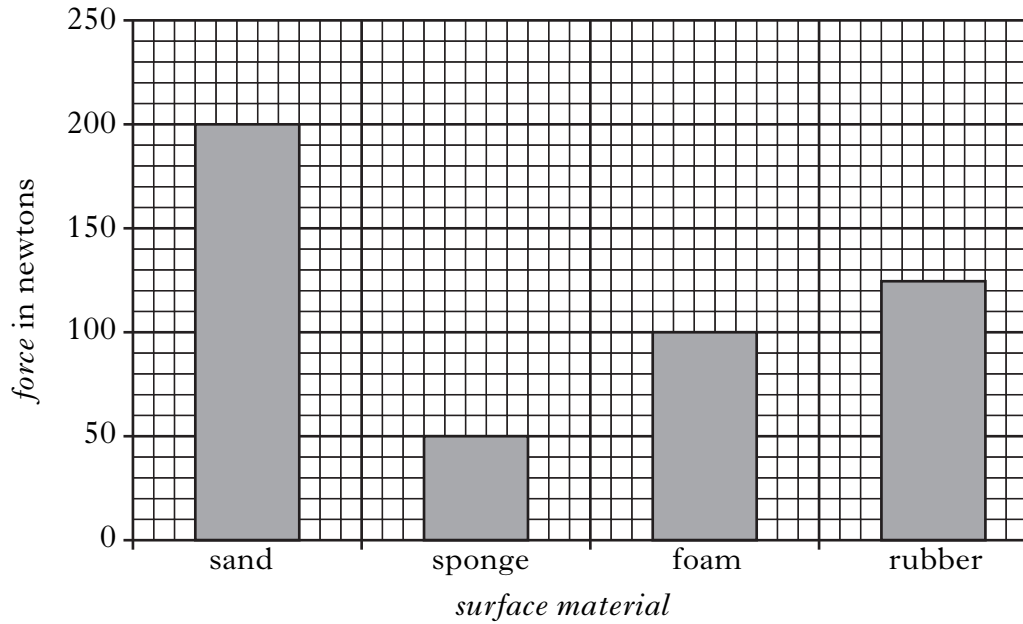

(a) (i) Which material should be used for the landing surface?

1

(ii) Explain your answer.

1

(iii) Why is the height kept the same each time?

1

Marks

28. (continued)

(b) The experiment is repeated with a dummy of smaller mass.

- (i) Will the maximum force exerted on the dummy **increase**, **decrease** or **stay the same**?

1

- (ii) Explain your answer.

1

[Turn over

Marks

29. (a) A bungee jumper wants to calculate his average speed during a jump. On the first descent he falls 63 metres in 4.5 seconds.

(i) What device can be used to measure the time of the descent?

1

(ii) Calculate his average speed during the descent.

2

(b) During a second descent the bungee jumper wears baggy clothing and spreads his arms out as he falls.



He falls 63 metres in 5 seconds.

(i) Why was the time greater for the second descent?

1

(ii) The bungee jumper has a mass of 65 kg. Calculate his weight.

2



Marks

30. A student investigates the properties of a thermistor. The student places the thermistor in a water bath and measures the resistance of the thermistor as the temperature rises.

(a) Is the thermistor an **input**, **process** or **output** device?

1

(b) A graph of the student's results is shown below.

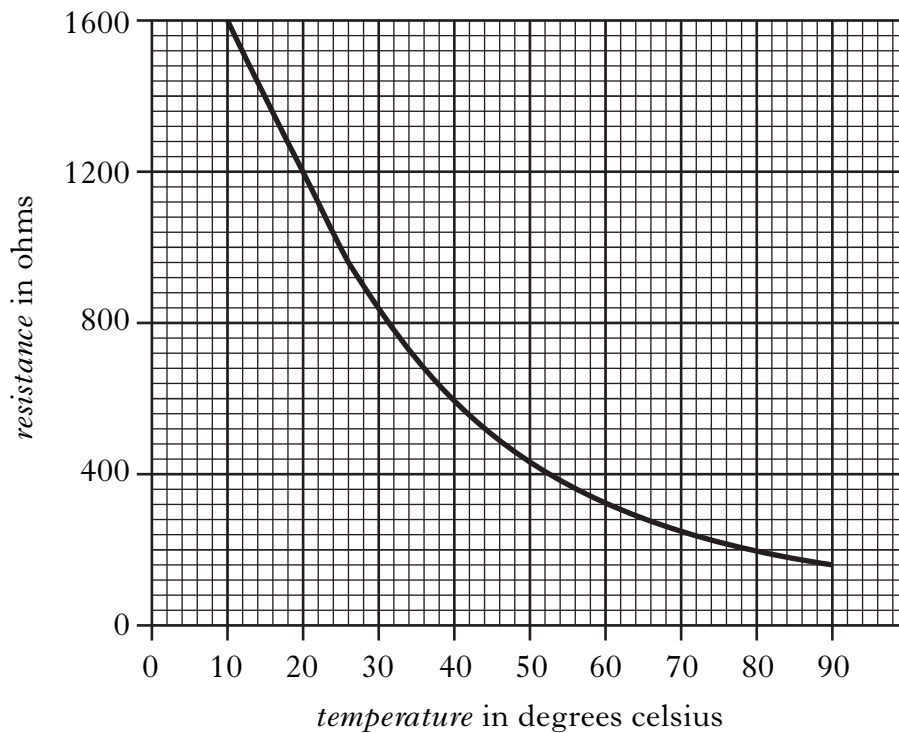

(i) What is the resistance at 20 degrees celsius?

1

(ii) What is the resistance at 80 degrees celsius?

1

(iii) What happens to the resistance of the thermistor as the temperature increases?

1

[Turn over

Marks

31. In a car, a warning sounds if the lights are left on after the ignition switch is turned off. The system has two inputs, one from the ignition switch and the other from the light switch.

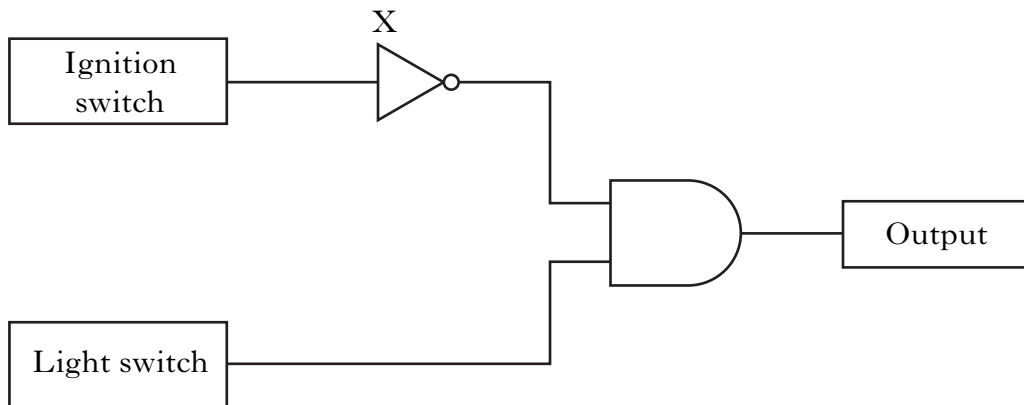

- (a) Name logic gate X.

1

- (b) Complete the logic table for gate X.

<i>Logic level from ignition switch</i>	<i>Output logic level from the gate</i>
0	
1	

1

- (c) Some electronic devices are listed below.

**microphone    buzzer    LDR    thermistor    motor**

Select an appropriate output device for this system.

1

*Marks*

**31. (continued)**

- (d) Explain why the output device is **on** when the ignition switch is **off** but the lights are **on**.

**2**

*[END OF QUESTION PAPER]*

*Marks*

**YOU MAY USE THE SPACE ON THIS PAGE TO REWRITE ANY ANSWER YOU HAVE DECIDED TO CHANGE IN THE MAIN PART OF THE ANSWER BOOKLET. TAKE CARE TO WRITE IN CAREFULLY THE APPROPRIATE QUESTION NUMBER.**

--