

FOR OFFICIAL USE

--	--	--	--	--	--

Total  
Marks

--

**X069/10/02**

NATIONAL MONDAY, 27 MAY  
QUALIFICATIONS 9.00 AM – 10.30 AM  
2013

PHYSICS  
INTERMEDIATE 1

Fill in these boxes and read what is printed below.

Full name of centre

--

Town

--

Forename(s)

--

Surname

--

Date of birth

Day Month Year

--	--	--	--	--	--

Scottish candidate number

--	--	--	--	--	--	--	--	--	--

Number of seat

--

Reference may be made to the Physics Data Booklet.

**Section A – Questions 1–20 (20 marks)**

Instructions for completion of **Section A** are given on page two.

For this section of the examination you must use an **HB pencil**.

**Section B (60 marks)**

All questions should be attempted.

The questions may be answered in any order but all answers are to be written in the spaces provided in this answer book, **and must be written clearly and legibly in ink**.

Rough work, if any should be necessary, should be written in this book, and then scored through when the fair copy has been written. If further space is required, a supplementary sheet for rough work may be obtained from the Invigilator.

Additional space for answers will be found at the end of the book. If further space is required, supplementary sheets may be obtained from the Invigilator and should be inserted inside the **front** cover of this booklet.

Before leaving the examination room you must give this book to the Invigilator. If you do not, you may lose all the marks for this paper.



## SECTION A

- 1 Check that the answer sheet provided is for Physics Intermediate 1 (Section A).
- 2 For this section of the examination you must use an **HB pencil** and, where necessary, an eraser.
- 3 Check that the answer sheet you have been given has **your name, date of birth, SCN** (Scottish Candidate Number) and **Centre Name** printed on it.  
Do not change any of these details.
- 4 If any of this information is wrong, tell the Invigilator immediately.
- 5 If this information is correct, **print** your name and seat number in the boxes provided.
- 6 The answer to each question is **either** A, B, C, D or E. Decide what your answer is, then, using your pencil, put a horizontal line in the space provided (see sample question below).
- 7 There is **only one correct** answer to each question.
- 8 Any rough working should be done on the question paper or the rough working sheet, **not** on your answer sheet.
- 9 At the end of the exam, put the **answer sheet for Section A inside the front cover of this answer book.**

### Sample Question

The energy unit measured by the electricity meter in your home is the

- A kilowatt-hour
- B ampere
- C watt
- D coulomb
- E volt.

The correct answer is **A**—kilowatt-hour. The answer **A** has been clearly marked in **pencil** with a horizontal line (see below).



### Changing an answer

If you decide to change your answer, carefully erase your first answer and, using your pencil, fill in the answer you want. The answer below has been changed to **E**.



## SECTION A

Answer questions 1–20 on the answer sheet.

1. Which three colours are used to produce a white area on a television screen?

- A Blue, green and yellow
- B Blue, green and red
- C Yellow, blue and green
- D Yellow, green and red
- E Blue, red and yellow

2. Television signals from a satellite are received by a curved reflector as shown.

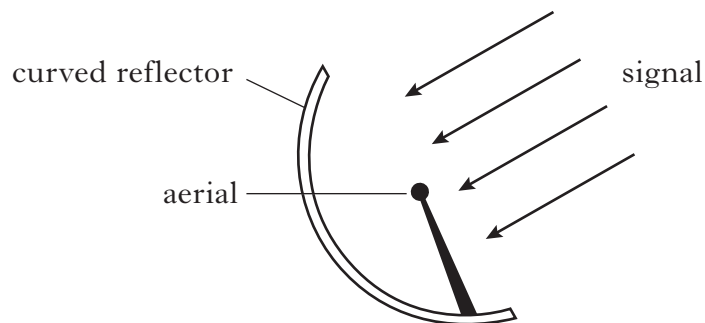

A curved reflector is used to

- A make the signal received at the aerial stronger
- B protect the aerial from the wind
- C select one signal from the many signals received at the reflector
- D convert electrical energy into light energy
- E convert light energy into electrical energy.

[Turn over

3. A student directs a ray of light onto a mirror.

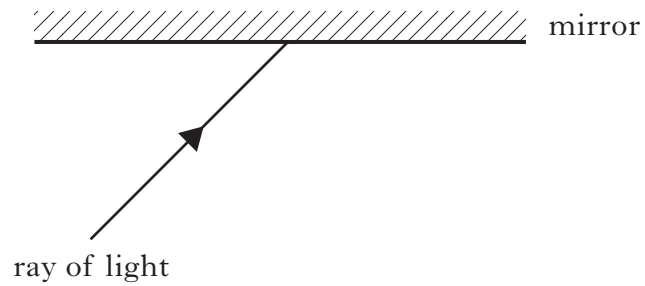

Which line on the diagram shows the ray after reflection?

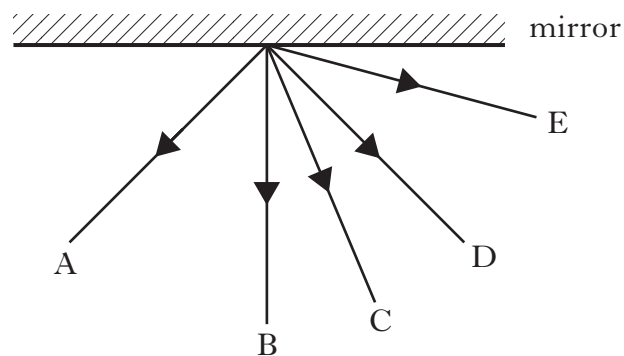

4. A student makes the following statements about optical fibres.

- I Optical fibres transmit light signals at a speed of 200 million metres per second.
- II Optical fibres are used for telecommunication links.
- III Optical fibres are used mainly to transmit sound signals.

Which of the statements is/are true?

- A I only
- B I and II only
- C I and III only
- D II and III only
- E I, II and III

5. A microphone and loudspeaker are parts of a telephone.

Which row in the table shows the useful energy change in the microphone and the loudspeaker?

	<i>Energy change in the microphone</i>	<i>Energy change in the loudspeaker</i>
A	sound to light	light to sound
B	electrical to sound	electrical to sound
C	sound to electrical	electrical to sound
D	sound to electrical	sound to electrical
E	electrical to sound	sound to electrical

6. Which circuit shows resistors P and Q connected in parallel with each other?

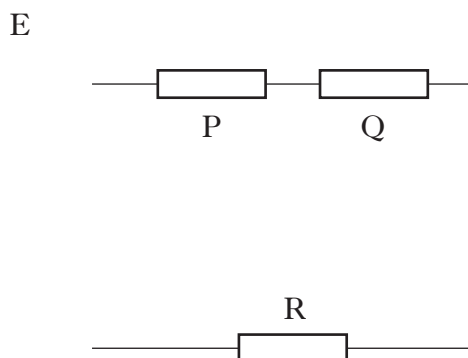
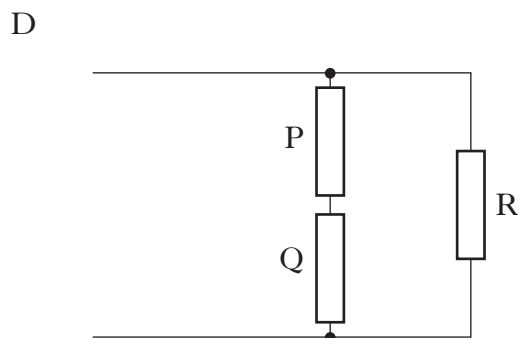
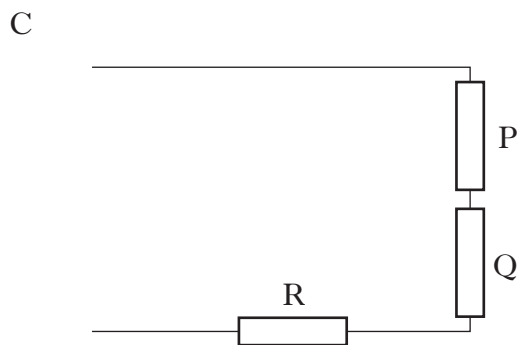
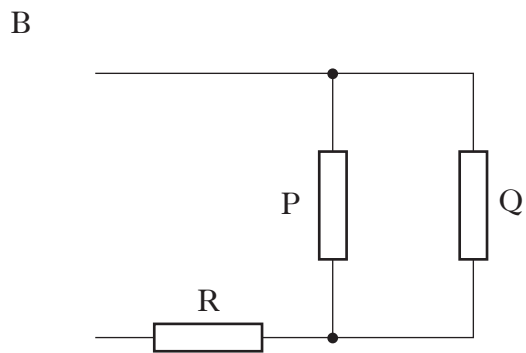
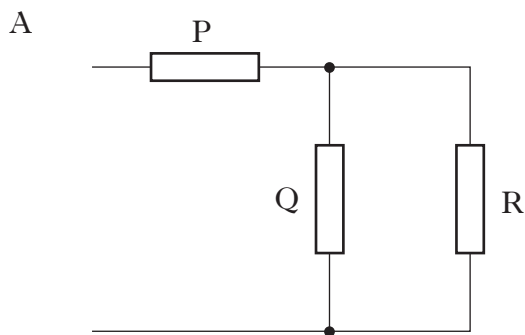

7. A circuit is set up as shown.

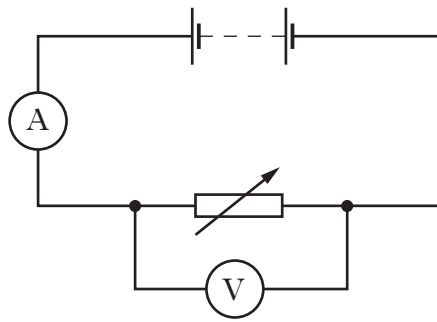

The reading on the ammeter is 3.0 amperes.

The reading on the voltmeter is 12 volts.

The resistance of the variable resistor is now increased.

Which row in the table gives possible new readings on the ammeter and voltmeter?

	<i>Reading on the ammeter in amperes</i>	<i>Reading on the voltmeter in volts</i>
A	2	12
B	2	14
C	3	14
D	3	12
E	4	12

8. A circuit is set up as shown.

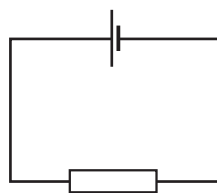

The energy change in the resistor is

- A electrical to heat
- B electrical to light
- C heat to electrical
- D light to electrical
- E electrical to sound.

9. A circuit is set up as shown.

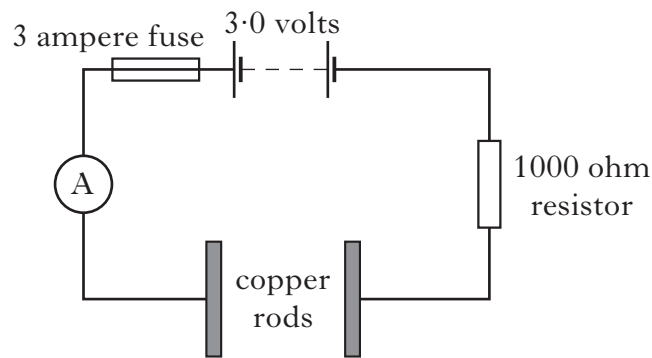

A student holds a copper rod in each hand and notes the reading on the ammeter. Which of the following produces a larger reading on the ammeter?

- A Changing the 3.0 volt battery to a 1.5 volt battery
- B Changing the 1000 ohm resistor to a 2000 ohm resistor
- C Repeating the experiment with wet hands
- D Replacing the ammeter with a voltmeter
- E Changing the fuse to a 5 ampere fuse

10. Which of the following best describes a laser beam?

- A A narrow beam of white light
- B A wide beam of white light
- C A wide beam of red light
- D A narrow beam of green light
- E A wide beam of green light

11. The diagram shows light rays from a far away object entering a person's eye.

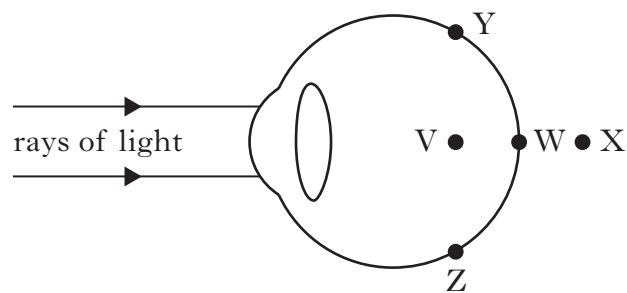

The person is short sighted. The light rays would focus at

- A point V
- B point W
- C point X
- D point Y
- E point Z.

12. In the following passage, three words have been replaced by the letters *X*, *Y* and *Z*.  
 Gamma radiation is *X* to the naked eye.  
 Gamma radiation *Y* kill living cells.  
 The strength of a source of gamma radiation *Z* with time.  
 Which row in the table gives the correct words for *X*, *Y* and *Z*?

	<i>X</i>	<i>Y</i>	<i>Z</i>
A	visible	can	increases
B	invisible	cannot	decreases
C	visible	can	decreases
D	visible	cannot	increases
E	invisible	can	decreases

13. An electronic keyboard is connected to a speaker.  
 A key is pressed to produce a note of 400 hertz.  
 Another key is now pressed to produce a note one octave higher.  
 The frequency of the new note is
- A 600 hertz
  - B 800 hertz
  - C 1000 hertz
  - D 1200 hertz
  - E 1600 hertz.
14. A student makes the following statements about how the frequency of a vibrating string can be increased.
- I Make the string longer.
  - II Make the string shorter.
  - III Make the string tighter.
- Which of the statements is/are correct?
- A I only
  - B II only
  - C III only
  - D I and III only
  - E II and III only



15. An alarm clock is inside a jar as shown.

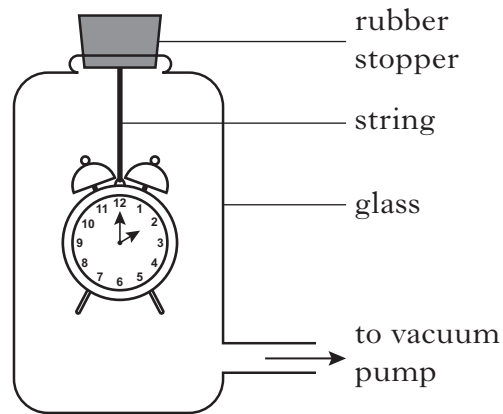

The sound from the alarm is heard clearly.

All of the air in the jar is now pumped out.

The alarm cannot be heard clearly because sound cannot pass through

- A the string
- B a vacuum
- C the glass
- D air
- E the rubber stopper.

16. Five cars are acted on by different forces.

Which car is speeding up to the right?

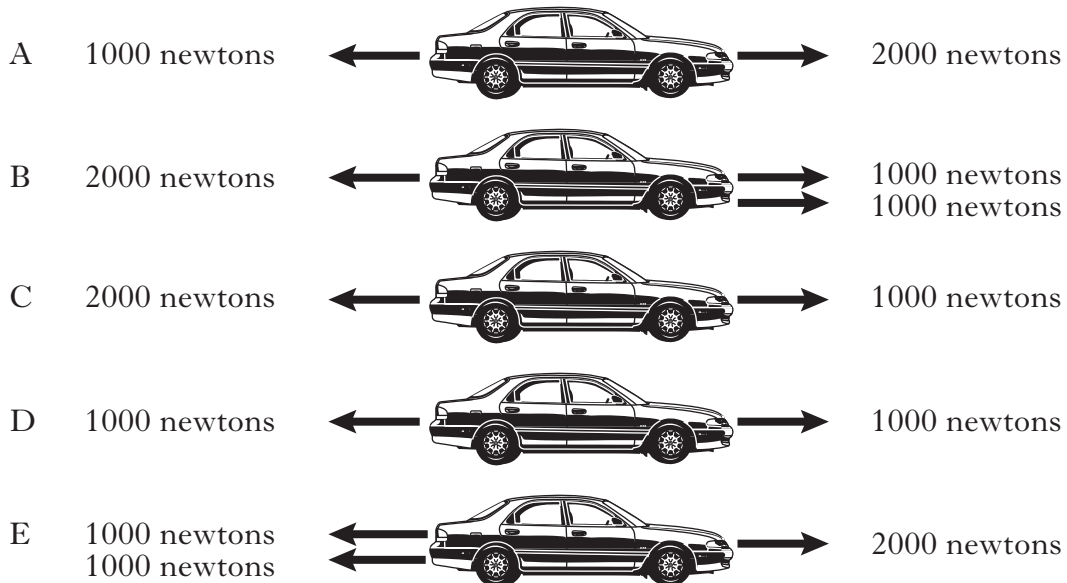

[Turn over

17. A ball is kicked at an angle  $x$  as shown.

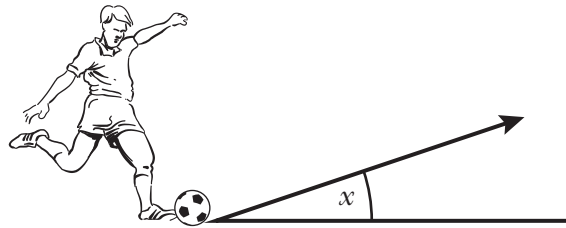

The angle is then changed.

The graph shows how the horizontal distance travelled by the ball changes as the angle is changed.

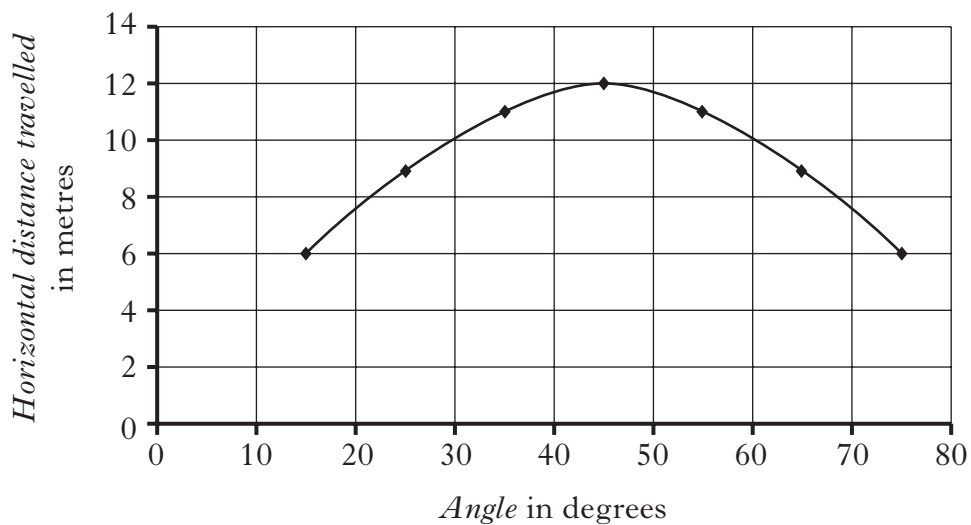



The ball travels the greatest horizontal distance when it is kicked at an angle of

- A 15 degrees
- B 40 degrees
- C 45 degrees
- D 50 degrees
- E 75 degrees.

18. Which of the following rows contains two output devices and one input device?

- A Loudspeaker, lamp, LED
- B Microphone, LDR, switch
- C Thermistor, switch, buzzer
- D Electric motor, buzzer, lamp
- E Loudspeaker, buzzer, thermistor

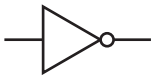

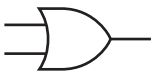
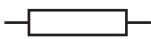

19. Which of the following is a symbol for an OR gate?

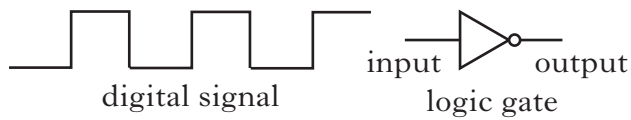
- A 
- B 
- C 
- D 
- E 

20. A digital signal is applied to the input of a logic gate as shown.



The output signal from the logic gate is

- A 
- B 
- C 
- D 
- E 

**Candidates are reminded that the answer sheet for Section A MUST be placed INSIDE the front cover of the answer book.**

**[Turn over for Section B on Page thirteen**

**[BLANK PAGE]**

## SECTION B

Answer questions 21–34 in the spaces provided.

21. Radio stations transmit signals at different frequencies.

(a) What is meant by the frequency of a radio signal?

1

(b) The table below lists the frequency of different radio stations.

<i>AM (amplitude modulated)</i>		<i>FM (frequency modulated)</i>	
<i>Station</i>	<i>Frequency (kilohertz)</i>	<i>Station</i>	<i>Frequency (megahertz)</i>
Clyde 2	1152	Argyll	106.5
Forth Two	1548	Clyde 1	102.5
Moray Firth Radio	1107	Forth One	97.3
Northsound	1035	Real Radio	100.3
Tay	1584	Smooth Radio	105.2
Radio 5	909	Waves Radio	101.2

One kilohertz = 1000 hertz

One megahertz = 1 000 000 hertz

(i) In the sentence below, circle **one** word in the box to make the statement correct.

FM radio stations have a HIGHER/LOWER frequency than AM radio stations.

1

(ii) Which station has a frequency that is between Northsound and Clyde 2?

1

[Turn over

Marks

22. The Earth rotates once every 24 hours.

The table below shows the time taken for a satellite to orbit the Earth at different heights above the surface of the Earth.

<i>Time to complete one orbit</i> (hours)	<i>Approximate height above the surface of</i> <i>the Earth</i> (kilometres)
12	20 000
18	28 000
24	36 000
30	44 000

(a) Use the table to find the height, in kilometres, of a Geostationary satellite.

**1**

Marks

22. (continued)

(b) Using the data in the table, plot a **line graph** on the grid provided.

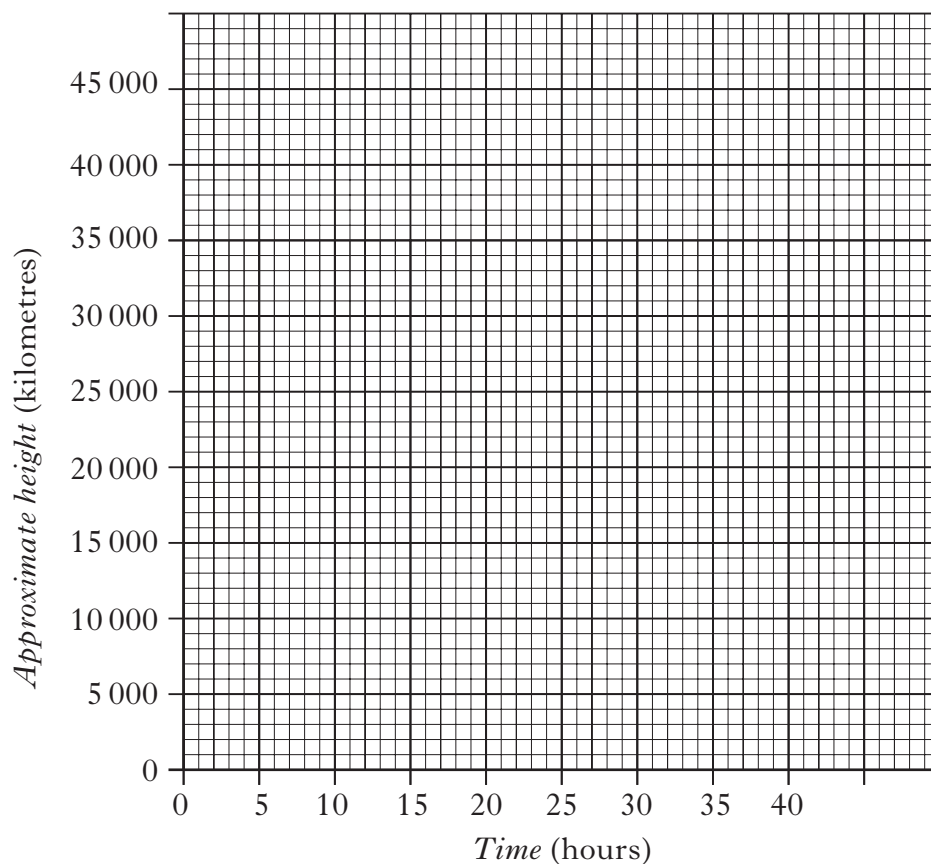

2

(c) From the graph find the time it would take for a satellite to orbit that is 30 000 kilometres above the Earth.

1

[Turn over

Marks

23. Luggage scanners at airports use radiation to check bags before they are put onto aircraft. An image on the TV screen can then show up anything that contains metal.

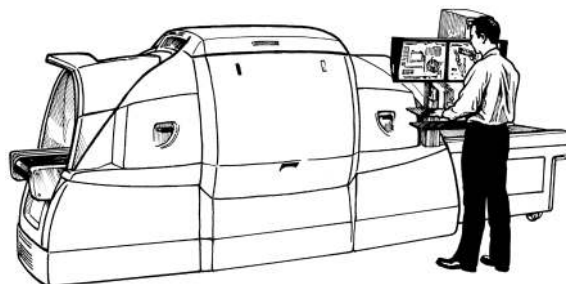

- (a) What type of radiation is used in the luggage scanner?

1

- (b) The radiation generator used in the scanner operates at a current of 4.0 amperes and a voltage of 220 volts. Calculate the resistance of this generator.

2



## 23. (continued)

- (c) Airport body scanners are used to detect whether a person is carrying weapons.



A person going through the scanner receives a radiation dose of 0.03 microsieverts every time it is used.

A person could have 5000 scans a year before there would be any risk to their health.

- (i) Calculate the total radiation dose value, in microsieverts, that would create a health risk to passengers.

	<b>2</b>
--	----------

- (ii) The security staff taking the scan sit behind a lead glass screen. What is the purpose of the screen?

	<b>1</b>
--	----------

Marks

24. A vacuum cleaner and its rating plate are shown below.

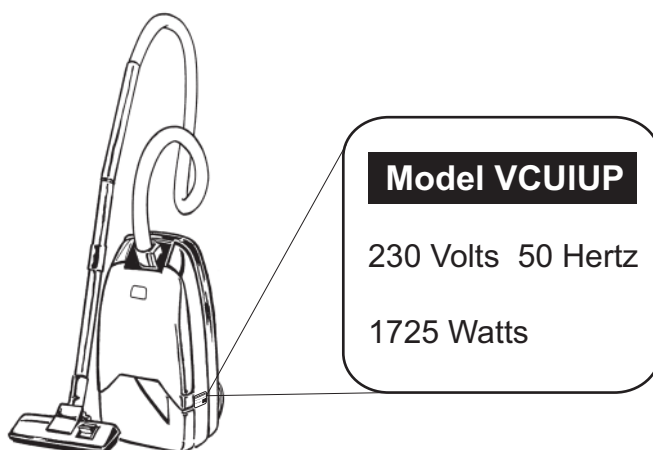

(a) Calculate the current in the vacuum cleaner when it is switched on.

2

(b) A plug is connected to the flex of the vacuum cleaner.

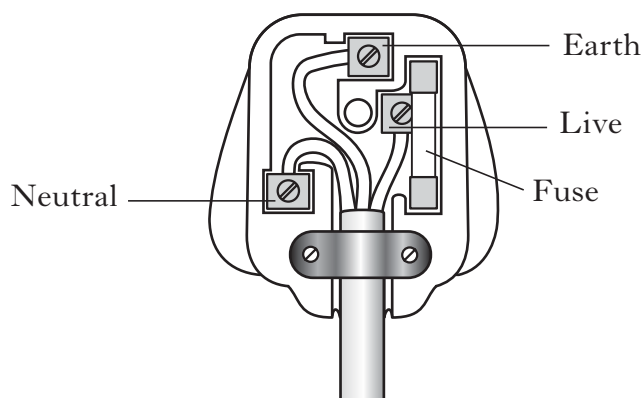

Complete the table below to identify the colours of the insulation on the wires inside the plug.

<i>Terminal</i>	<i>Colour</i>
Earth	
Live	
Neutral	

1

**24. (continued)***Marks*

- (c) The power rating and fuse values of some appliances are shown in the table below.

<i>Appliance</i>	<i>Power (watts)</i>	<i>Fuse value (amperes)</i>
Bedside lamp	60	3
Deep-fat fryer	3000	13
Desktop computer	150	X
Dishwasher	1200	Y
Sandwich maker	1000	13
Television	300	3

- (i) State the value of fuse X.

\_\_\_\_\_ amperes

- (ii) State the value of fuse Y.

\_\_\_\_\_ amperes

**2****[Turn over**

Marks

25. To investigate the resistance of different wires, four wires, W, X, Y and Z are tested in turn. All the wires are the same length.

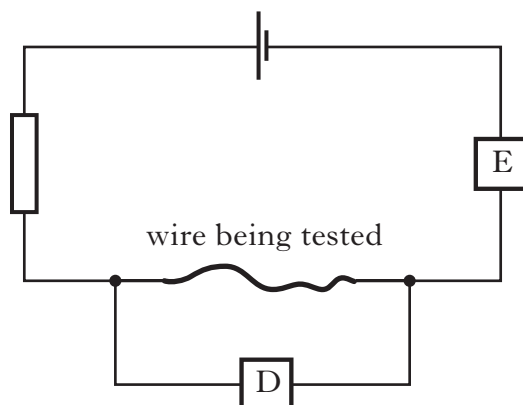

- (a) At which position in the circuit should an ammeter be placed, D or E?

1

- (b) The table shows the current in each wire.

Wire	Current (amperes)
W	0.50
X	0.60
Y	0.22
Z	0.80

- (i) Which wire has the smallest resistance?

1

- (ii) Explain your answer.

1

Marks

26. Ultrasound is used to determine the depth of the sea.

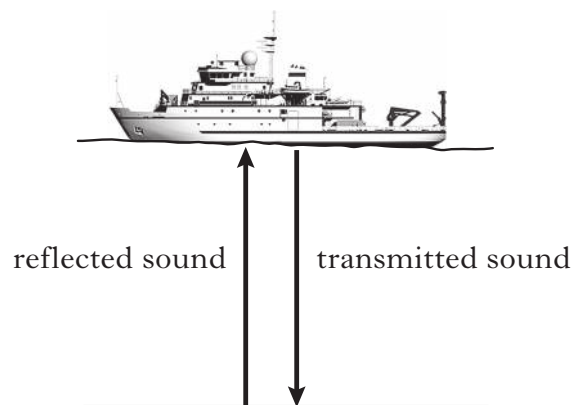

- (a) State what the term *ultrasound* means.

1

- (b) A pulse of ultrasound is transmitted and the echo is detected 1.2 seconds later.

- (i) Calculate the time taken for the pulse of ultrasound to reach the sea bed.

1

- (ii) The sea bed is 900 metres below the surface.  
Calculate the speed of sound in water.

2

Marks

27. Rescue workers use thermal imaging cameras to detect people who are trapped in collapsed buildings.

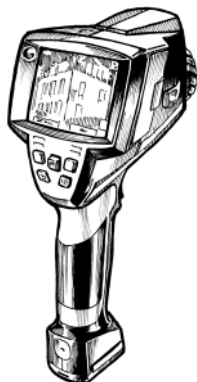

- (a) Describe how these cameras detect people trapped in a collapsed building.

1

- (b) The camera contains the lens shown below.

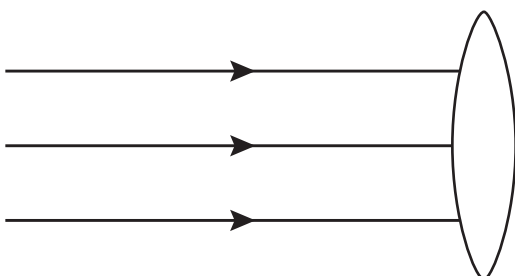

- (i) Name this type of lens.

1

- (ii) Complete the diagram above to show the path of the rays once they have passed through the lens.

1

## 27. (continued)

Marks

(c) The list below gives different types of radiation.

**Microwaves**                      **X-rays**                      **Visible light**  
**Infrared**                      **Ultraviolet**

Use some of these radiations to complete the table.

<i>Type of Radiation</i>	<i>Application</i>
	Used to detect flaws in metal structures
Gamma rays	Can be used as a tracer
	Helps to speed up muscle healing
	Can be used to identify security markings on banknotes

2

**[Turn over**

Marks

28. A student investigates how musical instruments produce sounds.

- (a) A guitar is fitted with an electric pick up so that the signal can be amplified.

The signal from the pick up to the input of the amplifier is shown on an oscilloscope below.

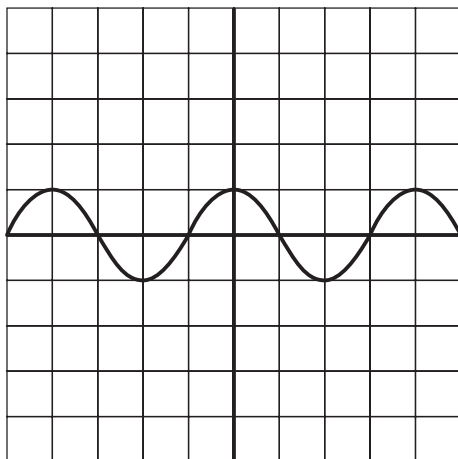

On the grid below draw the output signal from the amplifier. The settings on the oscilloscope have not been changed.

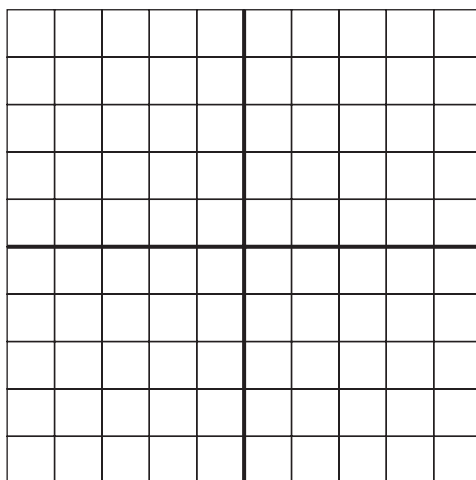

2

- (b) The student wears ear protectors to prevent damage to her hearing. Explain how the ear protectors work.

1



Marks

28. (continued)

- (c) Complete the following sentences about sound using some of the words in the list.

**amplitude      decibels      energy      frequency**  
**hertz          noise          vibrates**

Sound is a wave, which transfers . Sounds

are produced when an object . The

frequency of the wave is measured in  and

the loudness of the sound is measured in .

2

[Turn over

Marks

29. A concert is being broadcast live on radio.



(a) The signal from the singer's microphone is amplified before being broadcast.



Calculate the voltage gain of the amplifier.

2

(b) A person is listening to the broadcast on a radio receiver.

The block diagram below shows the main parts of a radio receiver.

Complete the diagram by filling in the missing labels.

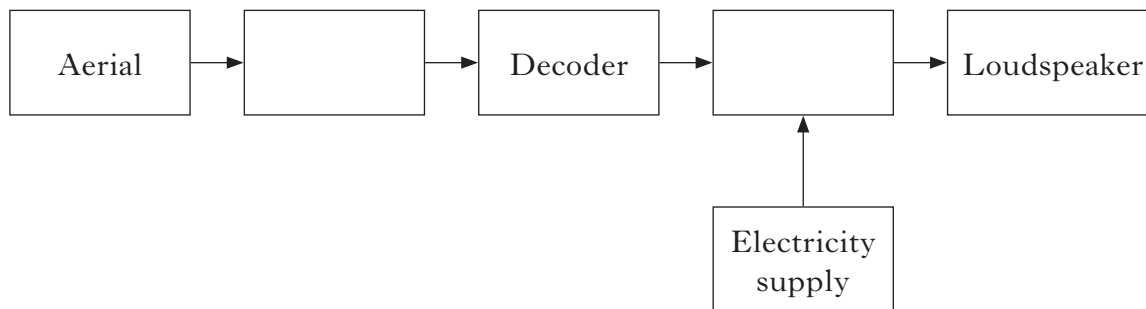

2

Marks

30. A kitesurfer stands on a small surfboard.

The wind exerts a force on the kite moving the kitesurfer across the water.

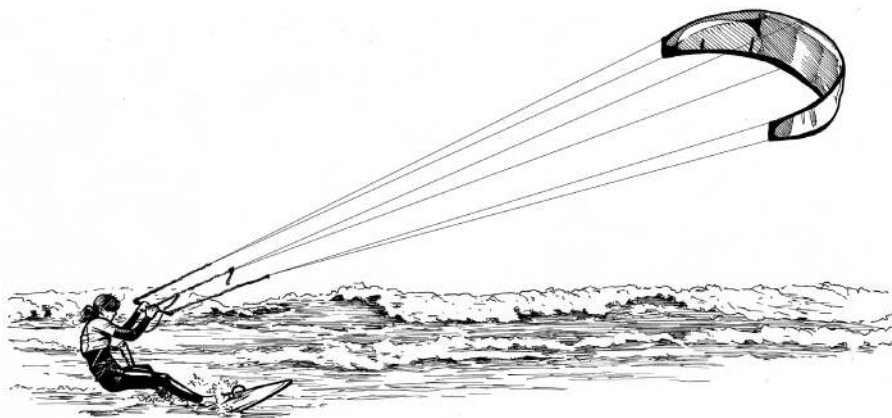

(a) The kitesurfer travels 750 metres in 60 seconds.

Calculate the average speed of the kitesurfer over this distance.

2

(b) The kitesurfer then travels at a constant speed.

How do the forces acting on the kitesurfer compare?

1

(c) Later the kitesurfer lifts clear of the surface of the water for a few seconds.

The wind speed stays the same but the speed of the kitesurfer increases.

Explain this increase in the speed of the kitesurfer.

1

Marks

31. A student carries out an experiment to measure the height a tennis ball rebounds to from different surfaces.

The student uses a tennis ball and samples of three different types of surface (carpet, laminate, vinyl).

Describe a method the student could use to carry out this experiment.

Your description should include:

Additional equipment the student would require.

The measurements the student should make.

How the student would ensure the test is fair.

3

Marks

32. (a) Complete the sentences below using some of these words.

**Earth      force      kilogram      newtons      weight**

Weight is the force due to gravity and it is measured in .

Weight is the pull of the  on an object.

1

- (b) A ball has a mass of 0.5 kilograms.

Calculate the weight of the ball.

2

- (c) The ball rolls down a hill.

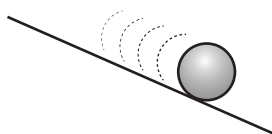

There is a force due to friction acting on the ball.

In which direction is the force of friction acting?

1

- (d) When the ball reaches the bottom of the hill it collides with a stationary ball of mass 1.5 kilograms.

After the collision the second ball moves off with a speed of 2.0 metres per second.

The second ball is now replaced by another ball of mass 2.5 kilograms and the experiment is repeated.

Will the speed of the 2.5 kilogram ball be **greater than, the same as or less than** 2.0 metres per second?

1

Marks

33. A freezer in a hospital is used to store medicines at a low temperature.

An electronic system is used to sound an alarm when the temperature of the freezer becomes too high.



- (a) An electronic system can be represented by a block diagram as shown.  
Complete the block diagram by filling in the missing labels.



1

- (b) The electronic system contains some of the components from the list below.

**buzzer      lamp      microphone      switch      thermistor**

- (i) Which device **from the list** is suitable as a temperature sensor?

1

- (ii) Which device **from the list** is suitable for sounding the alarm?

1

- (iii) The hospital technician adapts the system to detect someone opening the door of the freezer.

Name **one** input device **from the list** which is suitable for alerting that the door has been opened.

1

Marks

**33. (continued)**

- (c) A second system uses an LED as a warning device.  
State the energy change in an LED.

--

**1**

**[Turn over**

Marks

34. A hospital bed can be raised using an electronic circuit.

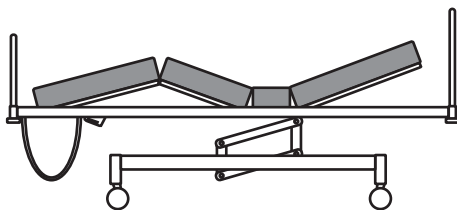

A logic diagram for this circuit is shown below.

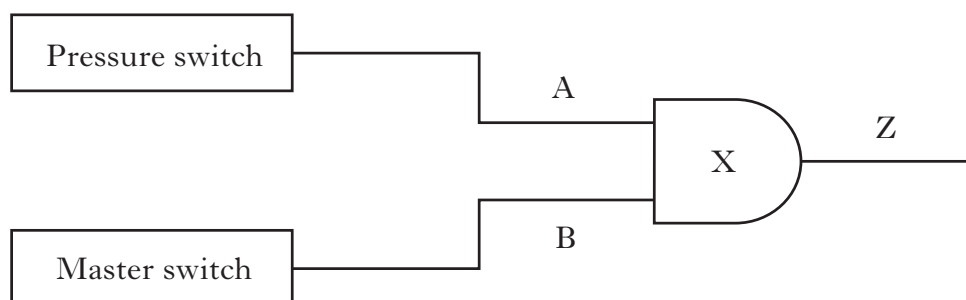

*Pressure switch when closed gives logic 1*  
*Pressure switch when open gives logic 0*

*Master switch when closed gives logic 1*  
*Master switch when open gives logic 0*

(a) (i) Name logic gate X.

1

(ii) Name an output device which could be used to raise the bed.

1



Marks

**34. (continued)**

(b) Complete the table for component X.

<i>Input A</i>	<i>Input B</i>	<i>Output Z</i>
0	0	
0	1	
1	0	
1	1	

**1**

(c) Explain why the bed cannot be raised when the master switch is off.

**1**

[END OF QUESTION PAPER]

**YOU MAY USE THE SPACE ON THIS PAGE TO REWRITE ANY ANSWER YOU HAVE DECIDED TO CHANGE IN THE MAIN PART OF THE ANSWER BOOKLET. TAKE CARE TO WRITE IN CAREFULLY THE APPROPRIATE QUESTION NUMBER.**

**YOU MAY USE THE SPACE ON THIS PAGE TO REWRITE ANY ANSWER YOU HAVE DECIDED TO CHANGE IN THE MAIN PART OF THE ANSWER BOOKLET. TAKE CARE TO WRITE IN CAREFULLY THE APPROPRIATE QUESTION NUMBER.**

**BLANK PAGE**