



National
Qualifications
2024

X857/76/12

**Physics
Paper 1 — Multiple choice**

THURSDAY, 25 APRIL

9:00 AM – 9:45 AM

Total marks — 25

Attempt ALL questions.

You may use a calculator.

Instructions for the completion of Paper 1 are given on *page 02* of your answer booklet X857/76/02.

Record your answers on the answer grid on *page 03* of your answer booklet.

Reference may be made to the data sheet on *page 02* of this question paper and to the relationships sheet X857/76/22.

Space for rough work is provided at the end of this booklet.

Before leaving the examination room you must give your answer booklet to the Invigilator; if you do not, you may lose all the marks for this paper.



* X 8 5 7 7 6 1 2 *

DATA SHEET

COMMON PHYSICAL QUANTITIES

Quantity	Symbol	Value	Quantity	Symbol	Value
Speed of light in vacuum	c	$3.00 \times 10^8 \text{ m s}^{-1}$	Planck's constant	h	$6.63 \times 10^{-34} \text{ Js}$
Magnitude of the charge on an electron	e	$1.60 \times 10^{-19} \text{ C}$	Mass of electron	m_e	$9.11 \times 10^{-31} \text{ kg}$
Universal Constant of Gravitation	G	$6.67 \times 10^{-11} \text{ m}^3 \text{ kg}^{-1} \text{ s}^{-2}$	Mass of neutron	m_n	$1.675 \times 10^{-27} \text{ kg}$
Gravitational acceleration on Earth	g	9.8 m s^{-2}	Mass of proton	m_p	$1.673 \times 10^{-27} \text{ kg}$
Hubble's constant	H_0	$2.3 \times 10^{-18} \text{ s}^{-1}$	Speed of sound in air	v_{air}	$3.40 \times 10^2 \text{ m s}^{-1}$

REFRACTIVE INDICES

The refractive indices refer to sodium light of wavelength 589 nm and to substances at a temperature of 273 K.

Substance	Refractive index	Substance	Refractive index
Diamond	2.42	Water	1.33
Crown glass	1.50	Air	1.00

SPECTRAL LINES

Element	Wavelength (nm)	Colour	Element	Wavelength (nm)	Colour
Hydrogen	656	Red	Cadmium	644	Red
	486	Blue-green		509	Green
	434	Blue-violet		480	Blue
	410	Violet	Lasers		
	397	Ultraviolet	Element	Wavelength (nm)	Colour
	389	Ultraviolet	Carbon dioxide	9550 } 10590 }	Infrared
Sodium	589	Yellow	Helium-neon	633	Red

PROPERTIES OF SELECTED MATERIALS

Substance	Density (kg m^{-3})	Melting point (K)	Boiling point (K)
Aluminium	2.70×10^3	933	2623
Copper	8.96×10^3	1357	2853
Ice	9.20×10^2	273
Sea Water	1.02×10^3	264	377
Water	1.00×10^3	273	373
Air	1.29
Hydrogen	9.0×10^{-2}	14	20

The gas densities refer to a temperature of 273 K and a pressure of $1.01 \times 10^5 \text{ Pa}$.

Total marks — 25
Attempt ALL questions

1. A cyclist travelling along a straight track accelerates at 1.2 m s^{-2} .
The speed of the cyclist increases from 4.0 m s^{-1} to 7.5 m s^{-1} .
The distance travelled by the cyclist during this acceleration is
- A 1.5 m
 - B 17 m
 - C 20 m
 - D 30 m
 - E 34 m.

[Turn over

2. A ball is thrown vertically upwards and returns to its original position.
Neglecting air resistance, which displacement-time ($s-t$) graph represents its motion?

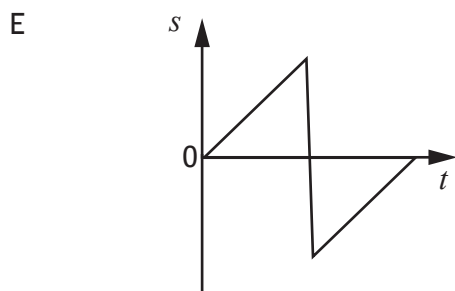
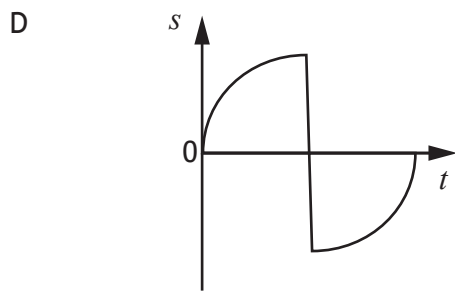
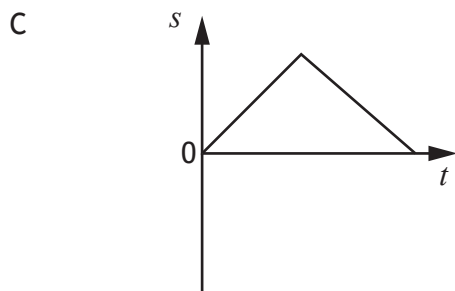
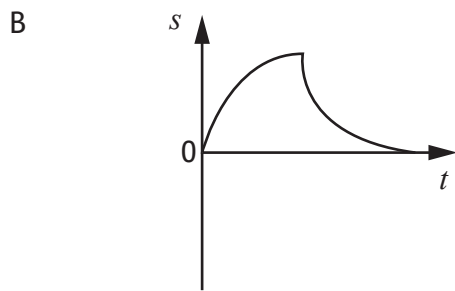
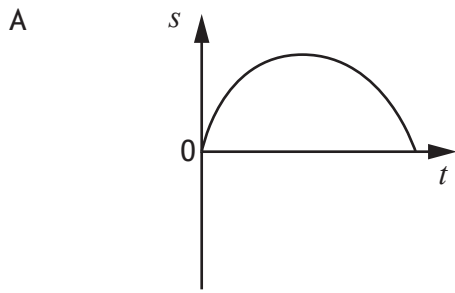

3. A box is suspended from a ceiling by a rope.
A horizontal force F is acting on the box.
The box is held stationary as shown.

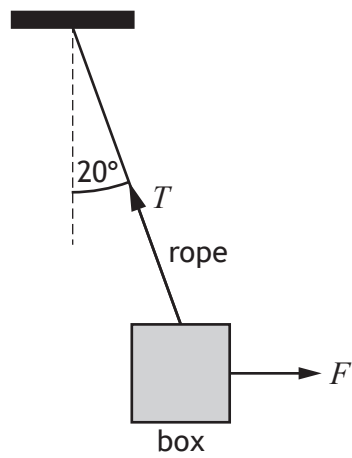

The weight of the box is 4.9 N.

The tension T in the rope is

- A 1.7 N
- B 4.6 N
- C 4.9 N
- D 5.2 N
- E 14 N.

[Turn over

4. A ball is thrown horizontally over the edge of a cliff.

A group of students draw three velocity-time ($v-t$) graphs to represent the motion of the ball, when air resistance is taken into account.

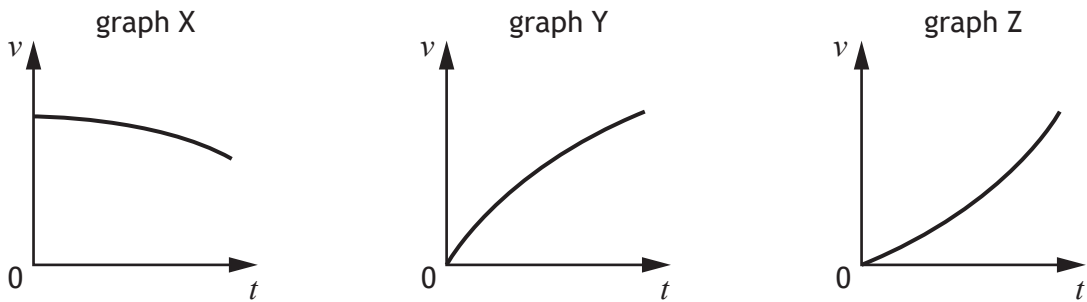

Which row in the table shows the graphs that represent the horizontal component of the velocity and the vertical component of the velocity?

	Horizontal component of the velocity	Vertical component of the velocity
A	graph X	graph Y
B	graph X	graph Z
C	graph Y	graph X
D	graph Y	graph Z
E	graph Z	graph X

5. In a hydroelectric power station water flows from a reservoir through turbines at a rate of 4.5×10^6 kg per minute.

The reservoir is 150 m above the turbines.

The total power delivered by the water in falling from the reservoir to the turbines is

- A 3.0×10^4 W
- B 7.5×10^4 W
- C 1.1×10^8 W
- D 6.6×10^9 W
- E 4.0×10^{12} W.

6. Two trolleys move along a level bench as shown.

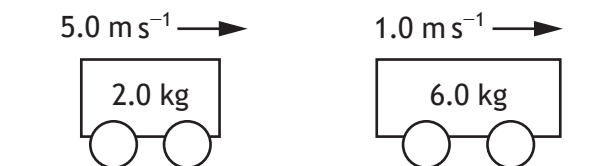

The trolleys collide and stick together. They continue to move along the bench.
The velocity of the trolleys immediately after the collision is

- A 0.50 m s⁻¹
B 1.3 m s⁻¹
C 2.0 m s⁻¹
D 2.7 m s⁻¹
E 8.0 m s⁻¹.
7. A spacecraft is travelling at a speed of $0.20c$ relative to the Earth.
The spacecraft emits a signal for 20.0 s as measured in the frame of reference of the spacecraft.
An observer on Earth measures the duration of the signal as
- A 19.2 s
B 19.6 s
C 20.0 s
D 20.4 s
E 20.8 s.
8. The Queensferry Crossing has a length of 2700 m as measured by a stationary observer on Earth.
A spaceship travels past Earth at a constant speed of 1.80×10^8 m s⁻¹ relative to Earth.
The length of the Queensferry Crossing as measured by an observer on the spaceship is
- A 1100 m
B 1700 m
C 2200 m
D 3400 m
E 4300 m.

[Turn over

9. The graph shows how the energy emitted per second per unit area varies with the wavelength of the radiation for four stars W, X, Y, and Z.

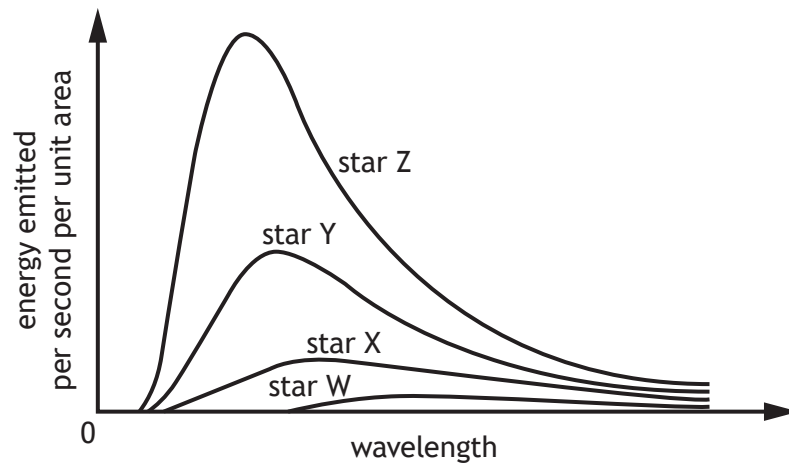

A student makes the following statements based on the information shown in the graph:

- I Star Z is hotter than star W.
- II The peak frequency of radiation emitted is greatest for star W.
- III Star Y emits more energy per second per unit area than star X.

Which of the statements is/are correct?

- A I only
 - B II only
 - C III only
 - D I and III only
 - E I, II and III
10. Which of the following particles is a fermion?
- A W-boson
 - B Z-boson
 - C Photon
 - D Gluon
 - E Muon

11. The following statement represents beta decay.

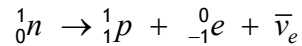

Beta decay provided the first evidence for the existence of the

- A quark
 - B neutrino
 - C electron
 - D proton
 - E neutron.
12. Uranium-239 (${}^{239}_{92}\text{U}$) undergoes decay by emitting a beta particle. The nucleus formed as a result of this decay also undergoes decay by emitting a beta particle to form nucleus X.

Nucleus X is

- A ${}^{231}_{88}\text{Ra}$
- B ${}^{235}_{90}\text{Th}$
- C ${}^{239}_{90}\text{Th}$
- D ${}^{239}_{93}\text{Np}$
- E ${}^{239}_{94}\text{Pu}$.

13. The following statement represents a nuclear reaction.

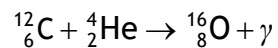

The total mass of the particles before the reaction is 26.572×10^{-27} kg.

The total mass of the particles after the reaction is 26.560×10^{-27} kg.

The energy released in this reaction is

- A 1.20×10^{-29} J
- B 3.60×10^{-21} J
- C 5.40×10^{-13} J
- D 1.08×10^{-12} J
- E 2.39×10^{-9} J.

[Turn over

14. A student carries out an experiment to investigate how irradiance of light varies with distance.

A small lamp is placed at a distance d from a light meter. The irradiance I at this distance is displayed on the light meter. This measurement is repeated for a range of different distances.

The student uses these results to plot the graph shown.

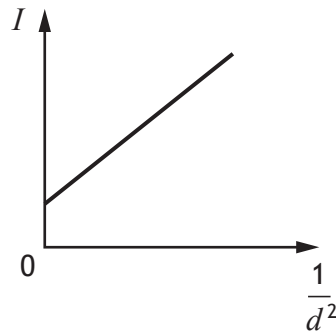

The graph indicates that there is a systematic uncertainty in the experiment.

Which of the following alterations would be most likely to reduce the systematic uncertainty in this experiment?

- A Repeating the experiment in a darkened room
 - B Repeating the readings at each distance and calculating averages
 - C Decreasing the brightness of the lamp
 - D Replacing the small lamp with a larger lamp
 - E Increasing the range of distances
15. A group of students make the following statements about coherent waves:
- I Coherent waves have a constant phase relationship.
 - II Coherent waves have the same frequency.
 - III Coherent waves have the same speed.

Which of the statements is/are correct?

- A I only
- B III only
- C I and II only
- D II and III only
- E I, II and III

16. Dark lines in an absorption spectrum occur because
- A photons move from higher to lower energy levels emitting electrons
 - B photons move from lower to higher energy levels by absorbing electrons
 - C electrons move from lower to higher energy levels emitting photons
 - D electrons move from higher to lower energy levels emitting photons
 - E electrons move from lower to higher energy levels by absorbing photons.

17. A ray of monochromatic light passes from air into diamond.

The frequency of the light in air is 5.09×10^{14} Hz.

The speed of this light in diamond is

- A $1.40 \times 10^2 \text{ m s}^{-1}$
- B $1.70 \times 10^6 \text{ m s}^{-1}$
- C $1.24 \times 10^8 \text{ m s}^{-1}$
- D $3.00 \times 10^8 \text{ m s}^{-1}$
- E $7.26 \times 10^8 \text{ m s}^{-1}$.

18. A circuit is set up as shown.

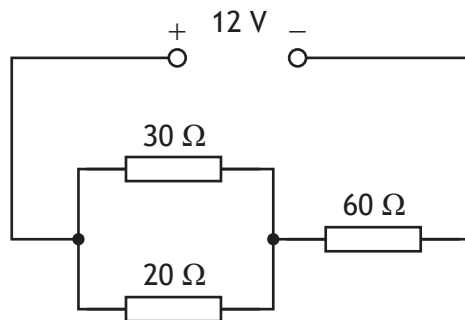

The power supply has negligible internal resistance.

The potential difference across the 60Ω resistor is

- A 1.0 V
- B 2.0 V
- C 5.5 V
- D 6.5 V
- E 10 V.

[Turn over

19. A resistor of resistance $2.2 \text{ k}\Omega$ is rated at 0.25 W .
 The potential difference across the resistor when operating at its rated power is
- A 0.11 V
 - B 23 V
 - C 94 V
 - D 550 V
 - E 8800 V .

20. A circuit is set up as shown.

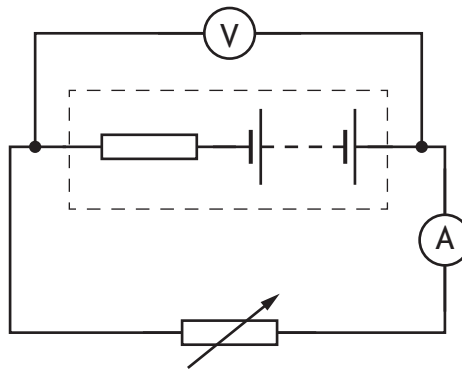

The resistance of the variable resistor is changed and the corresponding readings on the ammeter and voltmeter are used to produce the graph shown.

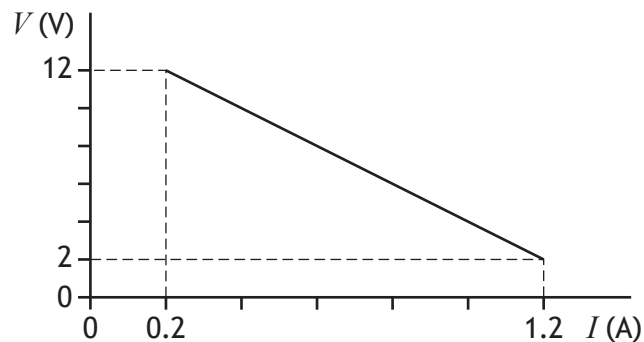

A student makes the following statements based on this information:

- I The EMF of the battery is 12 V .
- II The internal resistance of the battery is 10Ω .
- III The short circuit current is 1.2 A .

Which of these statements is/are correct?

- A I only
- B II only
- C III only
- D I and II only
- E I, II and III

21. A capacitor is initially uncharged.

The capacitor is now charged for 20 s using a supply that provides a constant current of 0.10 mA.

The potential difference across the capacitor is now 12 V.

The energy stored in the capacitor is

- A 0.06 mJ
- B 12.0 mJ
- C 14.4 mJ
- D 24.0 mJ
- E 28.8 mJ.

[Turn over

22. A circuit is set up as shown.

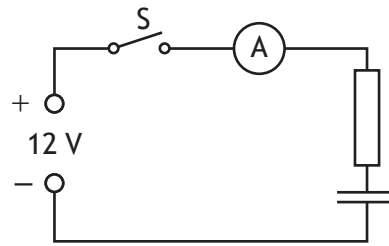

The capacitor is initially uncharged.

Switch S is now closed and the capacitor charges.

The graph shows how the charging current I in the circuit varies with time t .

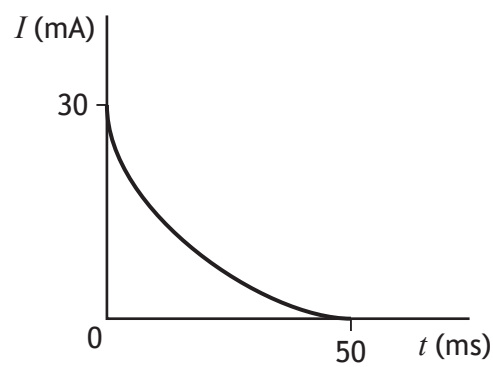

The capacitor is now replaced with an uncharged capacitor of greater capacitance.

The same charging process is repeated with this capacitor.

22. (continued)

Which graph shows how the current I varies with time t as this capacitor charges?

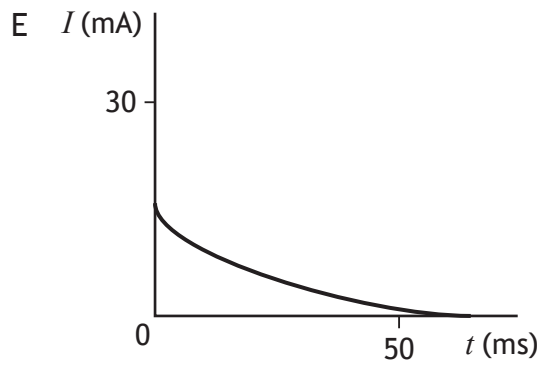
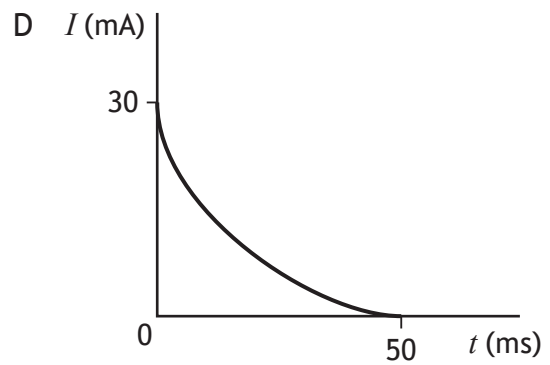
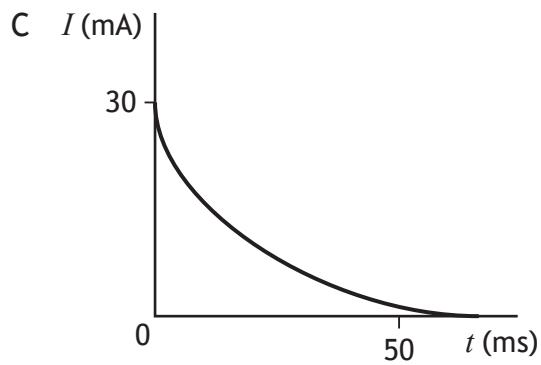
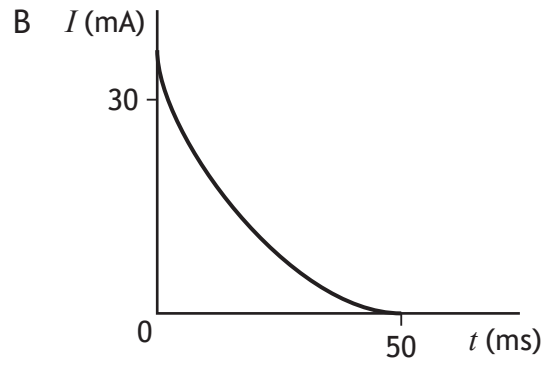
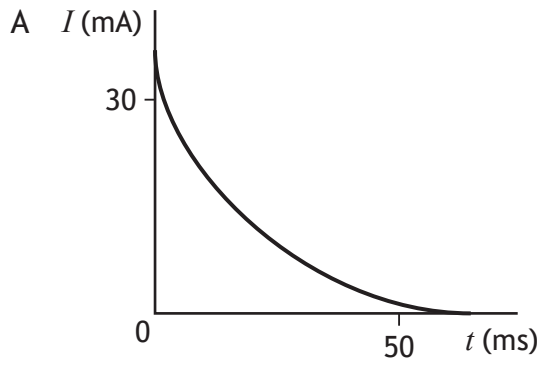

[Turn over

23. Solids can be categorised as conductors, insulators, or semiconductors.

The diagrams show the valence band and conduction bands of three solids X, Y, and Z.

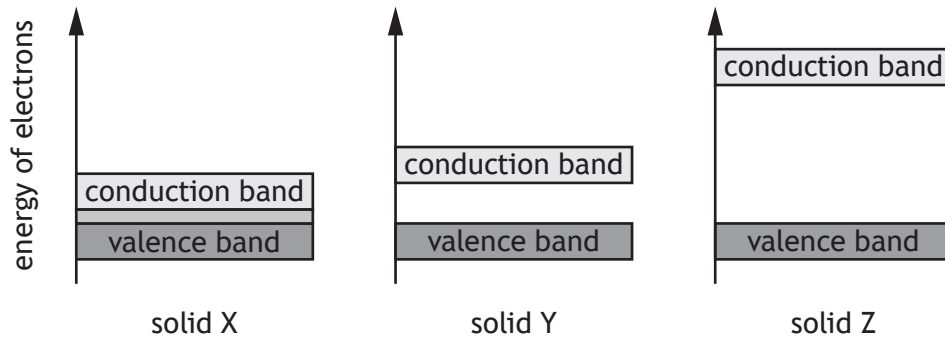

Which row in the table shows the letters that represent a conductor, an insulator, and a semiconductor?

	Conductor	Insulator	Semiconductor
A	X	Y	Z
B	Z	X	Y
C	Y	Z	X
D	X	Z	Y
E	Z	Y	X

24. An increase in the temperature of a semiconductor
- A increases its conductivity by allowing more electrons to reach the conduction band
 - B increases its conductivity by increasing the band gap between the valence band and the conduction band
 - C decreases its conductivity by allowing more electrons to reach the conduction band
 - D decreases its conductivity by allowing fewer electrons to reach the conduction band
 - E has no effect on its conductivity.
25. A student connects four identical red light emitting diodes (LEDs) to a 2 V rms AC supply as shown.

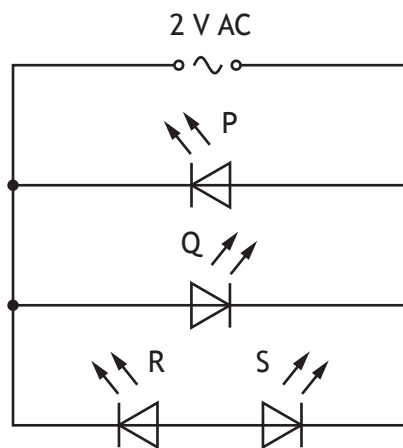

Which of the LEDs P, Q, R, and S will emit light?

- A P only
- B Q only
- C P and Q only
- D P and R only
- E Q and S only

[END OF QUESTION PAPER]

FOR OFFICIAL USE



--	--	--	--	--	--

National
Qualifications
2024

Mark

--

X857/76/01

**Physics
Paper 2**

THURSDAY, 25 APRIL

10:15 AM – 12:30 PM



* X 8 5 7 7 6 0 1 *

Fill in these boxes and read what is printed below.

Full name of centre

--

Town

--

Forename(s)

--

Surname

--

Number of seat

--

Date of birth

Day

--	--

Month

--	--

Year

--	--

Scottish candidate number

--	--	--	--	--	--	--	--	--	--

Total marks — 130

Attempt ALL questions.

You may use a calculator.

Reference may be made to the data sheet on *page 02* of this booklet and to the relationships sheet X857/76/11.

Care should be taken to give an appropriate number of significant figures in the final answers to calculations.

Write your answers clearly in the spaces provided in this booklet. Additional space for answers and rough work is provided at the end of this booklet. If you use this space you must clearly identify the question number you are attempting. Any rough work must be written in this booklet. Score through your rough work when you have written your final copy.

Use **blue** or **black** ink.

Before leaving the examination room you must give this booklet to the Invigilator; if you do not, you may lose all the marks for this paper.



* X 8 5 7 7 6 0 1 0 1 *

Total marks — 130
Attempt ALL questions

1. A Doppler ball consists of a loudspeaker and a battery-powered circuit board inside a foam ball.

Two students are throwing the ball to each other.

Student A throws the ball with a velocity of 11.0 m s^{-1} at an angle of 36.0° to the horizontal. The ball is released at a height of 1.60 m above the ground. The ball passes over the head of student B and lands on the ground at point Q.

The effects of air resistance can be ignored.

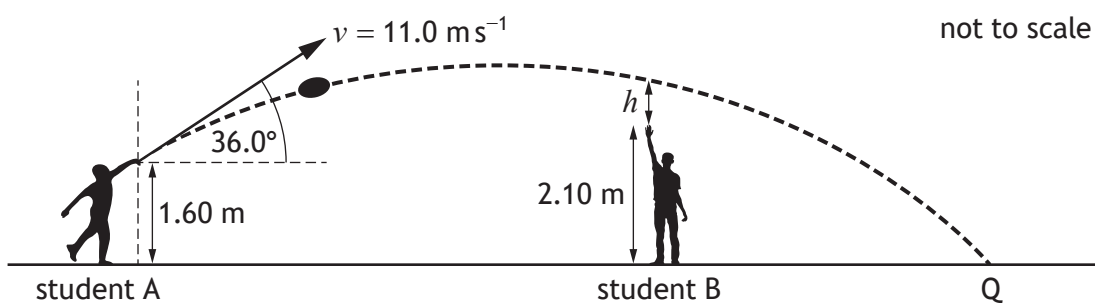

- (a) (i) Calculate:

- (A) the horizontal component of the initial velocity of the ball

1

Space for working and answer

- (B) the vertical component of the initial velocity of the ball.

1

Space for working and answer



1. (a) (continued)

(ii) The ball takes 1.53 s to travel from student A to point Q.
Calculate the horizontal distance travelled by the ball.

3

Space for working and answer

(iii) The ball was directly above student B 0.95 s after it was released.
Student B has a maximum reach of 2.10 m.

4

Determine the height h between student B and the ball.

Space for working and answer

[Turn over



1. (continued)

- (b) The Doppler ball is now threaded onto two ropes. There are handles at either end of the ropes.

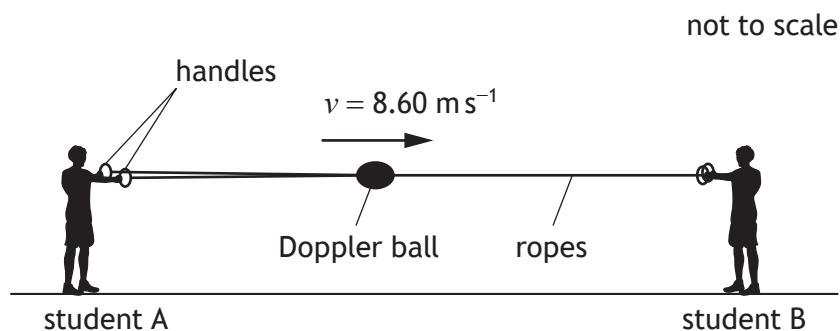

The circuit in the Doppler ball is switched on. The loudspeaker produces a sound of frequency 622 Hz.

Student A pulls the ropes apart and the Doppler ball travels along the ropes towards student B.

The ball travels horizontally along the ropes at a constant velocity of 8.60 m s^{-1} .

- (i) Calculate the frequency of the sound heard by student B as the Doppler ball approaches them.

Space for working and answer

3



1. (b) (continued)

- (ii) The foam Doppler ball collides with the handles at the end of the ropes held by student B and comes to rest.

Explain how the foam ball protects the circuit board during the collision.

2

[Turn over



2. A car pulls a caravan up a slope at a constant speed of 4.0 m s^{-1} . The slope is at an angle of 9.6° to the horizontal.

The car and passengers have a total mass of 1650 kg.

The caravan has a mass of 1350 kg.

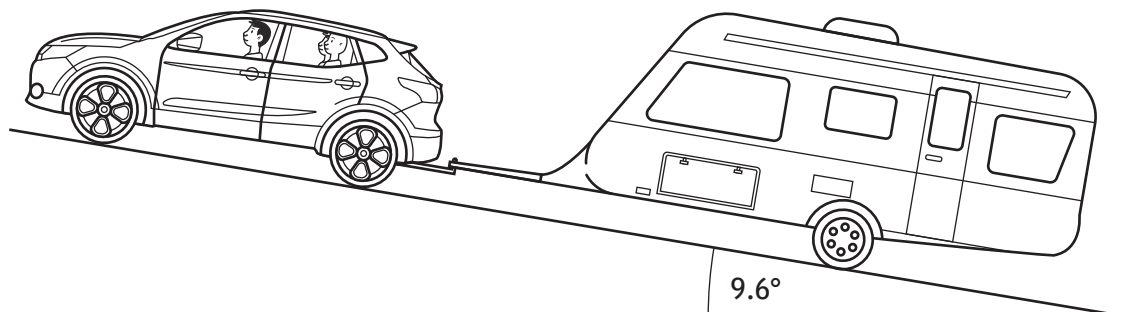

- (a) (i) Determine the component of the total weight of the car, passengers, and caravan acting down the slope.

3

Space for working and answer

- (ii) The total frictional force acting on the car and caravan is 1800 N. Determine the forward force produced by the car.

1

Space for working and answer



2. (continued)

(b) The car and caravan now accelerate uniformly up the slope for 250 s to a velocity of 9.5 m s^{-1} .

(i) Show that the acceleration of the car and caravan is 0.022 m s^{-2} .

2

Space for working and answer

(ii) Determine the minimum forward force produced by the car while accelerating.

3

Space for working and answer

(iii) State one assumption you have made in your calculation for (b) (ii).

1

[Turn over



2. (continued)

- (c) Later in the journey the car and caravan are being driven along a straight, level road.

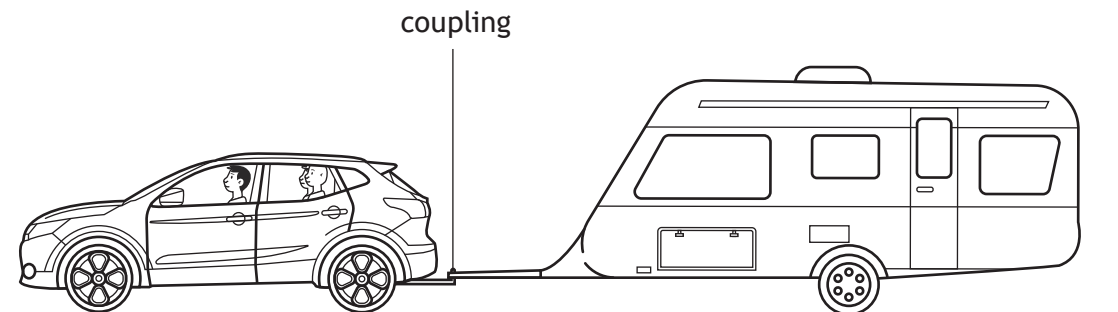

The car and caravan now accelerate at 0.16 m s^{-2} .

The frictional force acting on the car is 740 N.

The frictional force acting on the caravan is 1200 N.

Determine the tension in the coupling between the car and caravan.

3

Space for working and answer

3. A Newton's Cradle is a popular desk ornament.

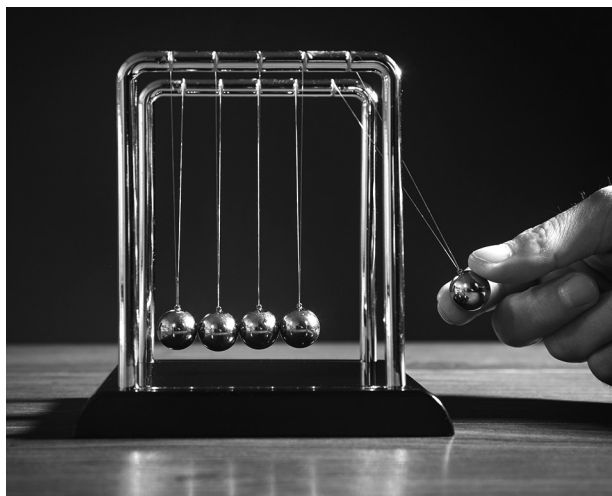

The ball at the end is raised and then released, striking the closest of the four stationary balls.

A force is transmitted through the stationary balls, which causes the ball at the opposite end to swing upwards.

This ball then swings back and strikes the stationary balls from the opposite direction and the process repeats.

A physics teacher states 'a Newton's Cradle can be used to demonstrate a number of physics principles.'

Using your knowledge of physics, comment on this statement.

3



4. On 26 September 2022, Double Asteroid Redirection Test (DART) collided with Dimorphos, a small asteroid that is in orbit around the larger asteroid Didymos. The aim of the mission was to test a defence system that could be used to redirect an asteroid that is on a collision course with Earth. When DART collided with Dimorphos, the kinetic energy of DART was transferred to Dimorphos. This caused Dimorphos to change its path.

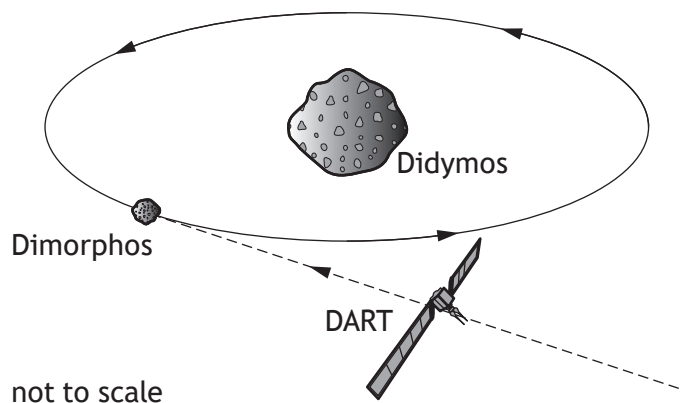

- (a) The mass of Didymos is taken to be 5.3×10^{11} kg.
 The mass of the Earth is 6.0×10^{24} kg.
- (i) Compare the mass of the Earth with the mass of Didymos in terms of orders of magnitude.
- Space for working and answer*

2

4. (a) (continued)

- (ii) When DART collided with Dimorphos, the distance between Earth and Didymos was 1.1×10^{10} m.

Determine the gravitational force between Earth and Didymos.

3

Space for working and answer

- (b) DART had a mass of 570 kg and was travelling at 6.6 km s^{-1} when it collided head-on with Dimorphos.

- (i) Calculate the maximum kinetic energy transferred from DART to Dimorphos during the collision.

3

Space for working and answer

[Turn over



* X 8 5 7 7 6 0 1 1 5 *

4. (b) (continued)

(ii) Complete the sketch graph of force F against time t for the force exerted on Dimorphos by DART during the collision.

Numerical values are not required on either axis.

(An additional diagram, if required, can be found on page 53.)

1



5. A group of students are participating in a demonstration that models the redshift of light from a distant star relative to an observer.

MARKS DO NOT WRITE IN THIS MARGIN

The 'star' is initially stationary relative to the observer.

The students leave the 'star' at intervals of 3.5 s and walk towards the observer.

Each student represents a wavefront of the light emitted by the 'star'.

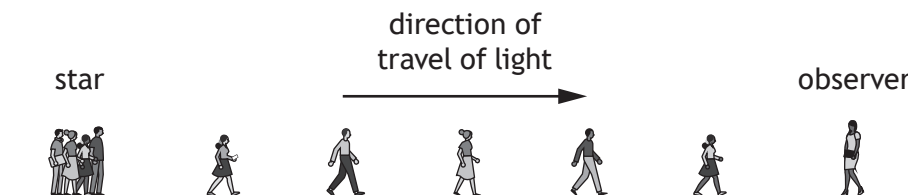

- (a) The students representing the wavefronts walk with a constant speed of 1.5 m s^{-1} towards the observer.

Determine the wavelength of the light represented by the students.

3

Space for working and answer

- (b) The demonstration is repeated, and the 'star' now moves at a constant speed relative to the observer. The wavefronts are still emitted from the 'star' at intervals of 3.5 s.

The pattern now observed is shown below.

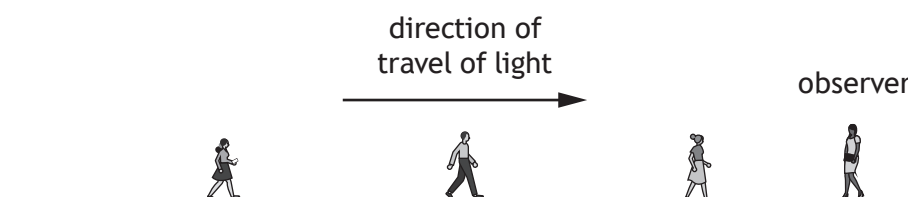

State if the 'star' is moving towards or away from the observer.

You must justify your answer.

2



* X 8 5 7 7 6 0 1 1 8 *

5. (continued)

(c) Redshift is evidence for the concept of the expanding Universe. Another piece of evidence for the expansion of the Universe is Olber's paradox.

(i) Explain how Olber's paradox, also referred to as the dark sky paradox, supports the concept of the expanding Universe.

2

(ii) State one other piece of evidence that supports the concept of the expanding Universe.

1

[Turn over



6. A teacher uses the apparatus shown to demonstrate the deflection of a beam of electrons by a magnetic field.

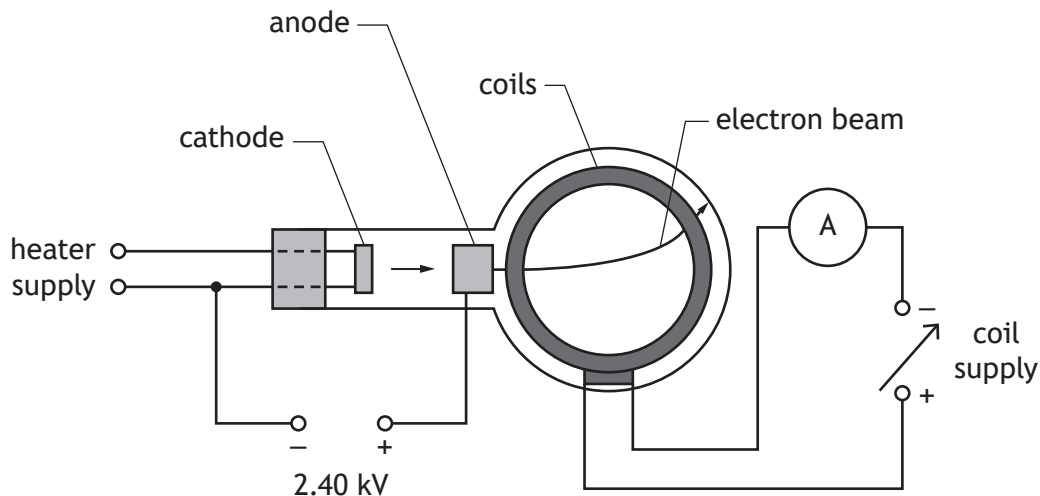

- (a) The heater supply is used to heat the cathode, which causes electrons to be released from its surface.

The electrons are accelerated from rest towards the anode by a potential difference of 2.40 kV.

- (i) Complete the diagram below, to show the electric field pattern between the cathode and anode.

(An additional diagram, if required, can be found on *page 53*.)

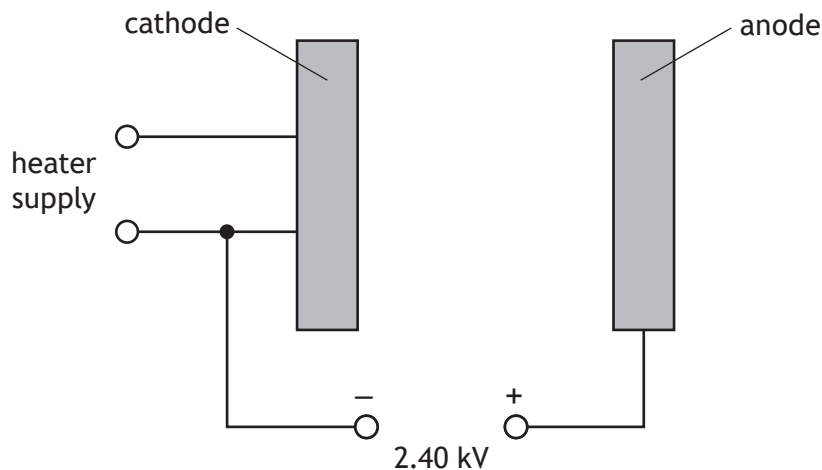

1



6. (a) (continued)

- (ii) The gain in kinetic energy for each electron moving from the cathode to the anode is 3.84×10^{-16} J.

Calculate the maximum speed of an electron as it reaches the anode.

3

Space for working and answer

- (iii) The cathode and anode are separated by a distance of 45.0 mm.

Calculate the maximum acceleration of an electron between the cathode and the anode.

3

Space for working and answer

[Turn over



6. (continued)

- (b) A small hole in the anode allows a narrow beam of electrons to be produced. The beam of electrons passes into a uniform magnetic field between the coils. The diagram shows the path taken by the electrons in the uniform magnetic field.

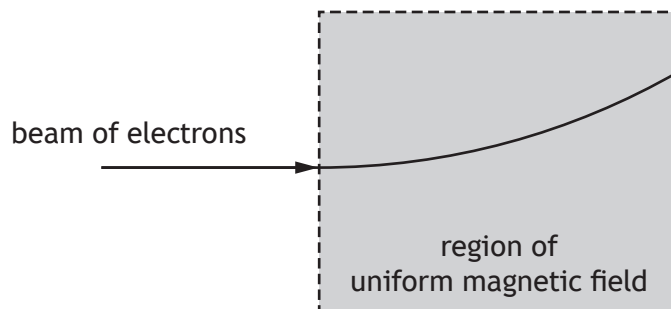

Determine the direction of the uniform magnetic field.

1

7. The art of matryoshka involves making a set of wooden dolls of decreasing size that are placed one inside another.



When one doll is opened up, a smaller one can be found inside, until eventually the last and smallest doll is reached. The smallest doll is a solid piece of wood.



A student states ‘Particle physics is just like matryoshka dolls. Look inside a particle and you will always find something similar, just smaller.’

Using your knowledge of physics, comment on this statement.

3

8. A group of students is conducting an experiment to investigate the relationship between the power output of two small filament lamps and the relative brightness of each lamp.

The relative brightness can be determined using an oil spot photometer.

The experiment is set up as shown.

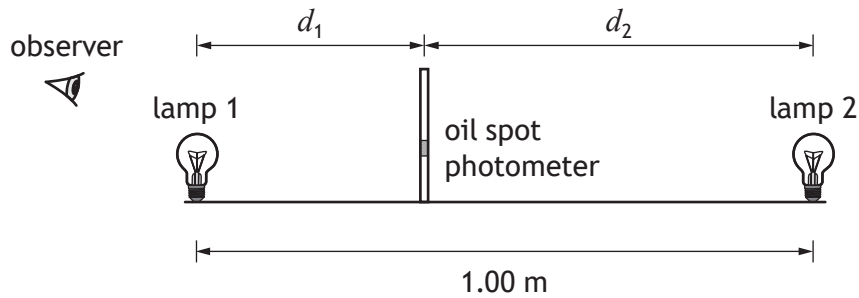

The oil spot photometer is a piece of card with an oil spot on it, which is used to compare the brightness of two light sources on either side of the photometer. When the relative brightness of the light on either side of the photometer is equal, no spot is observed.



8. (continued)

MARKS
DO NOT
WRITE IN
THIS
MARGIN

- (a) The students keep the brightness of lamp 1 constant.
The brightness L_2 of lamp 2 is measured using a light meter.
The photometer is moved until no spot is observed.
The distance d_2 between lamp 2 and the photometer is measured.
The brightness of lamp 2 is then increased and the process is repeated.
The following results are obtained.

L_2 (units)	d_2 (m)
5.00	0.350
10.00	0.495
15.00	0.606
20.00	0.700

Use **all** of the data in the table to establish that the relationship between the brightness L_2 and the distance d_2 when no oil spot is observed is

$$\frac{L_2}{d_2^2} = \text{constant}$$

3

Space for working and answer

- (b) Suggest why small, spherical lamps were used for this experimental procedure. 1



8. (continued)

- (c) The students repeat the experiment outside, to determine the luminosity of the Sun.

Luminosity is a measure of radiated electromagnetic power, measured in watts.

The set up for this experiment is shown below.

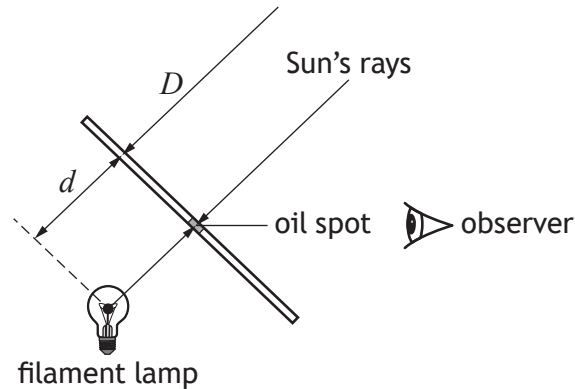

The luminosity of the Sun can be determined using the relationship

$$\frac{L_{lamp}}{d^2} = \frac{L_{Sun}}{D^2}$$

where: L_{lamp} is the luminosity of the lamp, in watts

L_{Sun} is the luminosity of the Sun, in watts

d is the distance between the lamp and the photometer, in metres

D is the approximate distance from the Sun to Earth, in metres.

The luminosity of the lamp is 1.0×10^2 W.

The approximate distance between the Sun and the Earth is 1.5×10^{11} m.

The students adjust the photometer position until the oil spot disappears and note the distance between the centre of the lamp and photometer.

The students repeat the process five times and record the following results:

$$d = 0.88 \text{ m}, 0.86 \text{ m}, 0.90 \text{ m}, 0.89 \text{ m}, 0.86 \text{ m}$$



8. (c) (continued)

(i) Determine the mean value for d .
Space for working and answer

1

(ii) Calculate the random uncertainty in the mean value for d .
Space for working and answer

2

(iii) Using the data from this experiment, determine the luminosity of the Sun.

An uncertainty in this value is not required.

Space for working and answer

2

[Turn over



9. A student uses the apparatus shown to investigate the photoelectric effect.

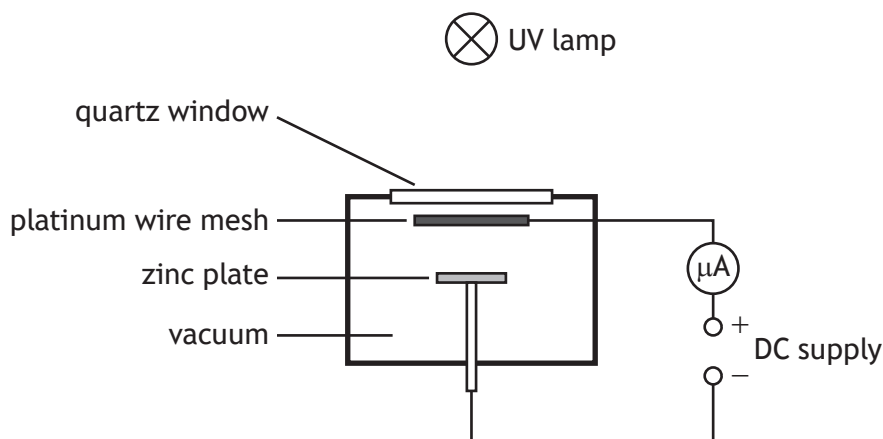

When the lamp is switched on, ultraviolet (UV) radiation passes through the quartz window and wire mesh, and is incident on the zinc plate.

A current of $5.00 \mu\text{A}$ is produced in the circuit.

- (a) (i) The lamp emits UV radiation with a frequency of $1.25 \times 10^{15} \text{ Hz}$.
Calculate the energy of a photon of the UV radiation.

3

Space for working and answer

- (ii) The work function of zinc is $5.81 \times 10^{-19} \text{ J}$.
Explain why UV radiation with a frequency of $1.25 \times 10^{15} \text{ Hz}$ produces a current in this circuit.

2



9. (continued)

(b) The student now moves the UV lamp closer to the quartz window.

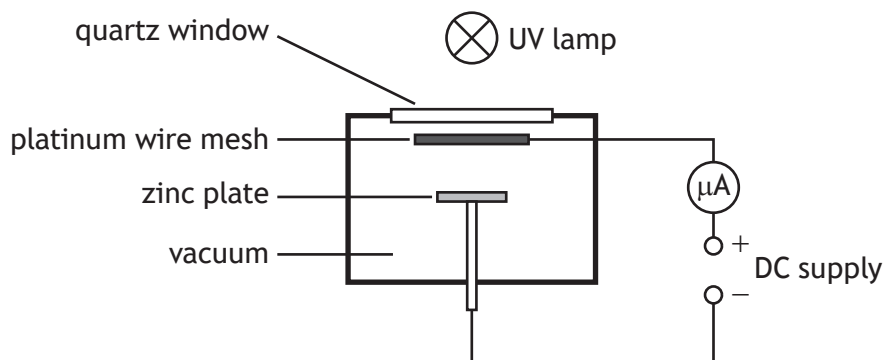

State whether the current in the circuit increases, decreases, or stays the same.

You must justify your answer.

2

[Turn over

9. (continued)

(c) The student now reverses the polarity of the DC supply.

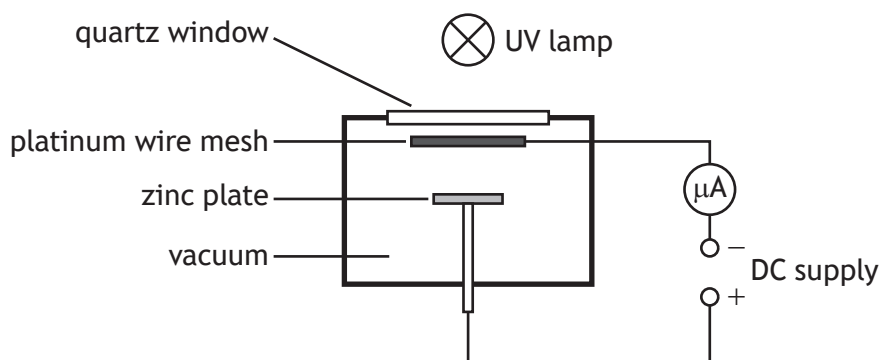

State the effect this change has on the current in the circuit.

Justify your answer.

2

10. A group of students is investigating interference of sound waves.
The students connect two loudspeakers to the same output of a signal generator.

MARKS DO NOT WRITE IN THIS MARGIN

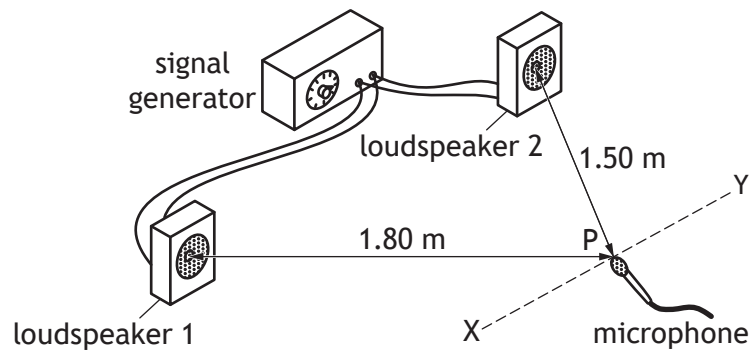

The signal generator produces a signal of frequency 1700 Hz.

- (a) Calculate the wavelength of the sound produced by the speakers.

3

Space for working and answer

- (b) As the microphone is moved from X to Y, regions of maxima and minima are detected.

Point P is a distance of 1.80 m from loudspeaker 1 and a distance of 1.50 m from loudspeaker 2.

Show by calculation whether constructive interference or destructive interference is detected at point P.

4

Space for working and answer



* X 8 5 7 7 6 0 1 3 4 *

10. (continued)

- (c) Loudspeaker 1 is now disconnected from the signal generator.

State the effect this has on the amplitude of the sound detected by the microphone at point P.

Justify your answer.

2

[Turn over



11. Spectral emission lines are unique to each element. These lines are produced when electrons make transitions between two energy levels and photons of light are emitted as a result.

The diagram represents some of the energy levels for a hydrogen atom.

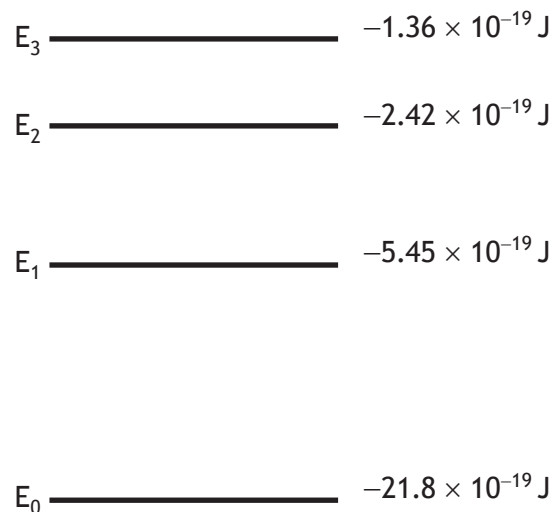

(a) For the energy levels shown:

- (i) determine the number of possible emission lines caused by the transition of electrons between the energy levels

1

- (ii) identify the electron transition that results in the emission of a photon with the shortest wavelength.

1



11. (continued)

MARKS
DO NOT
WRITE IN
THIS
MARGIN

(b) An electron makes the transition from E_3 to E_1 .

(i) Determine the wavelength of the photon of light emitted.

4

Space for working and answer

(ii) State the colour of this photon of light.

1

(c) The image below shows part of the line emission spectrum for a hydrogen atom. The red emission line is brighter than the others.



Explain why the red emission line is brighter than the others.

2

[Turn over



12. A student is investigating refraction of light using the apparatus shown.

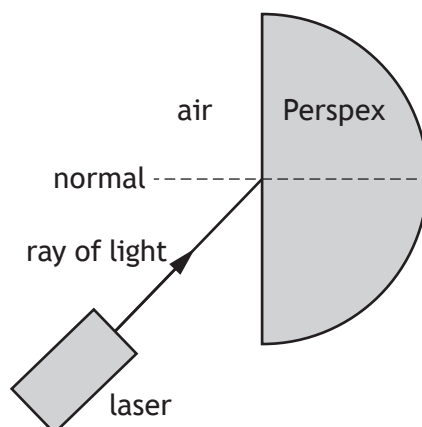

- (a) The student measures a number of different angles of incidence θ_i and the corresponding angles of refraction θ_r .

Suggest how the student's measurements should be processed to find a reliable value for the refractive index of Perspex for the light from the laser.

2

- (b) The student determines the refractive index of the Perspex block for this light to be 1.50.

Calculate the critical angle of Perspex for this light.

3

Space for working and answer



12. (continued)

(c) The student now directs the ray of light into the Perspex block as shown.

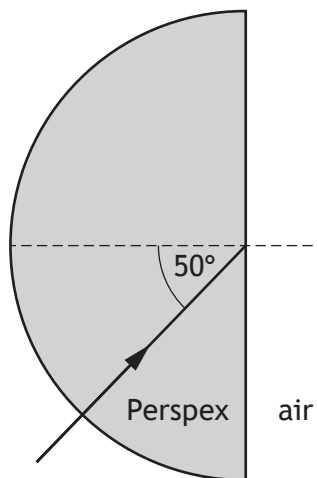

Complete the diagram to show the path of the ray of light after it is incident on this Perspex-air boundary.

Mark on the diagram the values of any relevant angles.

(An additional diagram, if required, can be found on *page 53*.)

2

[Turn over

13. The output from a signal generator is connected to the input terminals of an oscilloscope.
 The trace observed on the oscilloscope screen and the Y-gain setting are shown.
 The timebase setting is not shown.
 The frequency of the signal displayed on the oscilloscope is 250 Hz.

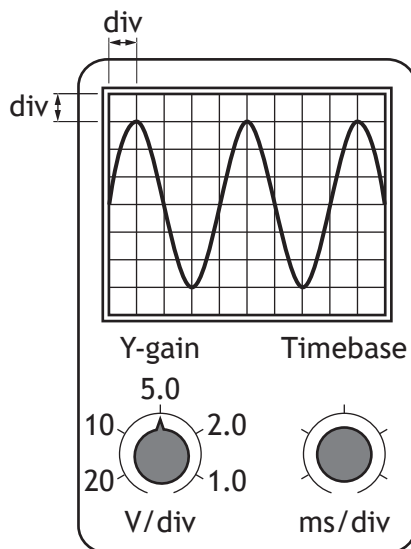

- (a) State what is meant by the term *alternating current (AC)*. 1
- (b) Determine the rms voltage of the signal. 3
Space for working and answer

13. (continued)

(c) Determine the timebase setting on the oscilloscope.

Space for working and answer

3

[Turn over



14. A technician sets up the following circuit.

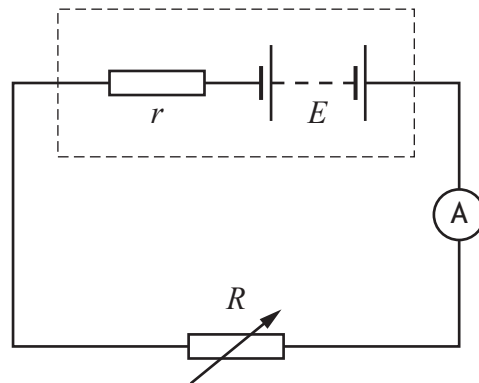

The technician uses readings of resistance R and current I from the circuit to produce the graph shown.

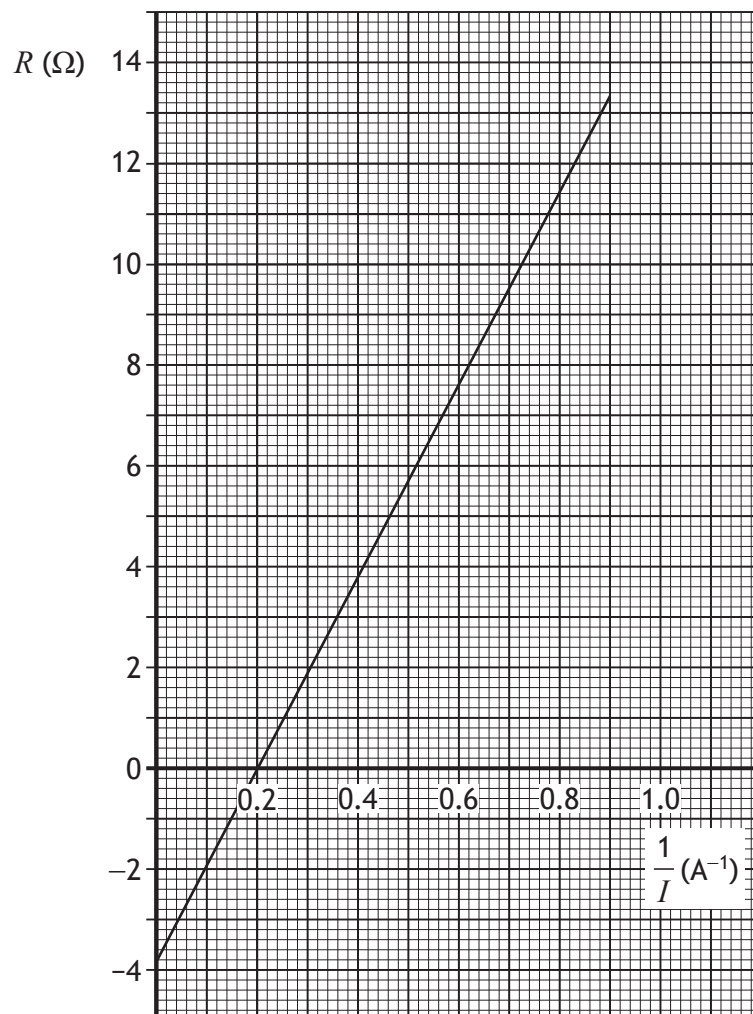

14. (continued)

Conservation of energy applied to the complete circuit gives the following relationship.

$$R = \frac{E}{I} - r$$

This relationship is in the form of the equation of a straight line.

$$y = mx + c$$

(a) Use the graph to determine:

(i) the internal resistance of the battery

1

(ii) the EMF of the battery

2

Space for working and answer

(iii) the short circuit current.

2

Space for working and answer

[Turn over



14. (continued)

- (b) The technician now connects a second variable resistor in parallel with the original variable resistor.

State whether the short circuit current for this circuit will be greater than, less than, or the same as the value determined in (a) (iii).

Justify your answer.

2



15. A set of garden lights is powered by an array of solar cells.

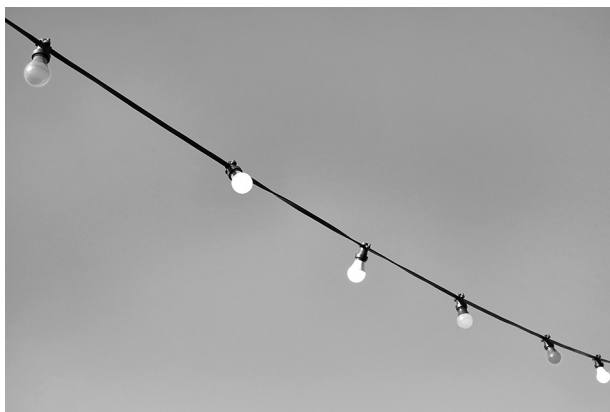

The set of garden lights consists of 10 LEDs connected in parallel.

Each LED is connected in series with a resistor.

The combined resistance of each LED and resistor is $220\ \Omega$.

Part of the circuit is shown.

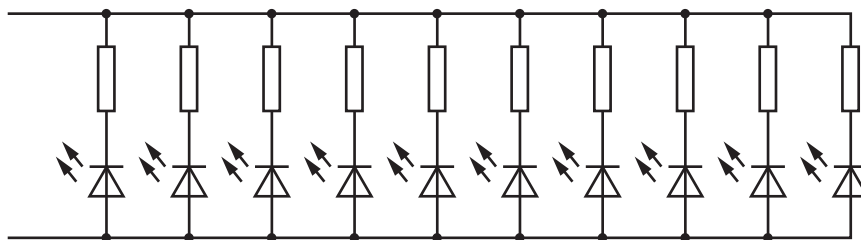

(a) Calculate the total resistance of this part of the circuit.

3

Space for working and answer

15. (continued)

(b) A solar cell is a p-n junction.

When photons of light are incident on the p-n junction, a potential difference is produced.

(i) State the name of this effect.

1

(ii) Using band theory, explain how a potential difference is produced when photons of light are incident on the p-n junction.

3

[Turn over



16. A group of students use the apparatus shown to carry out an investigation into Hooke's Law and find the spring constant k of a spring.

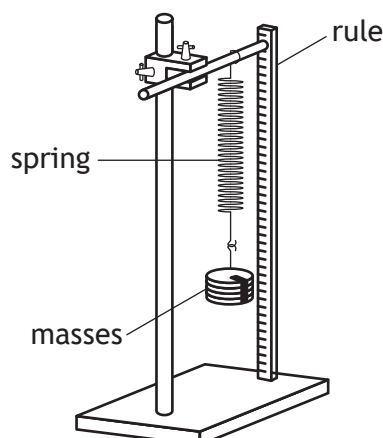

The spring constant k is a measure of the stiffness of a spring.

Hooke's Law states that the increase in the length of a spring is proportional to the force used to stretch the spring:

$$F = ke$$

where: F is the force used to stretch the spring, in N

k is the spring constant, in N m^{-1}

e is the increase in the length of the spring, in m.

The students obtain the following data.

F (N)	e (mm)
1.0	3
2.0	8
2.9	11
3.9	15
4.9	20
5.9	24

- (a) (i) Using the square-ruled paper on page 50, draw a graph of F against e .
(The table of results is also shown on page 51, opposite the square-ruled paper.)

3



16. (a) (continued)

MARKS DO NOT WRITE IN THIS MARGIN

- (ii) Use your graph to determine the spring constant k .

2

Space for working and answer

- (iii) Suggest one improvement to the experimental procedure that the students could make to improve the accuracy of their final result.

1

- (b) When a spring is extended, work is done. Elastic potential energy is stored in the spring. If it is not over-stretched, the elastic potential energy is equal to the work done.

The elastic potential energy can be determined using the relationship

$$E_e = \frac{ke^2}{2}$$

where: E_e is the elastic potential energy, in J

k is the spring constant, in N m^{-1}

e is the increase in the length of the string, in m.

Determine the elastic potential energy stored when the spring extension is 22 mm.

2

Space for working and answer

[END OF QUESTION PAPER]

